



**CATERHAM®**

**ASSEMBLY GUIDE**

DURATEC – EDITION 2.4

**CATERHAM®**

**ASSEMBLY GUIDE**

DURATEC – EDITION 2.4

Your feedback and comments are welcome: [assemblyguide@caterham.com](mailto:assemblyguide@caterham.com)

For help and build support enquiries contact: [buildsupport@caterham.com](mailto:buildsupport@caterham.com)

For help and support with IVA and registrations contact: [ivaapplications@caterham.com](mailto:ivaapplications@caterham.com)



## WELCOME TO YOUR NEW CATERHAM KIT

Building your own Caterham is immensely rewarding and satisfying. Of course, it should be remembered that you are building a high performance sports car, not a flat-pack wardrobe, so it will be a little challenging from time to time; but we've set out to make it as easy as possible for anyone, whatever their skill level and help is just a phone call away.

But before you do anything else, pop the kettle on or pour yourself a G&T with a slice; and

### **READ THE NEXT THREE PAGES - THEY ARE REALLY IMPORTANT**

No, they will not be very exciting unfortunately, but they are important nonetheless and you will regret it later if you don't.

So there are four important things we need to think about **NOW** before picking up a spanner:

- **This isn't the only guide you'll need**
- **When to apply for an IVA test**
- **Photography (no, really)**
- **Arranging a post build check**

Although we have made this guide as comprehensive as possible, the requirements of IVA change from time to time and even from test centre to test centre. Therefore, it **MUST** be read in conjunction with the 'IVA Checklist Guide', the latest version of which can be **downloaded from the Caterham website**. You'll find the refer-to-IVA-manual symbol in the bottom of each illustration where attention is required. Reading through it now, will save pain later! Don't assume that because you've found a reference to one item relating to that page, it is the only one...

Once you have completed the assembly of your Seven, you are required by law to present it for an 'Individual Vehicle Approval' test (better known as IVA), which is conducted by the Vehicle and Operator Services Agency (VOSA) at a regional test centre.

We **STRONGLY** recommend that you apply for your IVA appointment at least a month before you think you will complete your build, to allow for the application form to be processed at the snail's pace of bureaucracy. Once accepted, your IVA application is valid for 6 months and test dates can be changed up to a minimum of 3 working days prior to your appointment with VOSA (any later and you may incur a charge).

The IVA and Registration application forms, and a guide on how to complete them, are sent out on request when you are midway or nearing completion of your build. Please email [ivaapplications@caterham.com](mailto:ivaapplications@caterham.com) for a copy of your prefilled documents.



VOSA and the DVLA are a suspicious bunch and in order to register your car, you will need to provide proof that it is amateur built. When you apply for registration, you will need to include photos from various stages of you build, which will demonstrate to them that it is an 'amateur build'.

Recruiting a few extras (your kids, your spouse, the cat, etc.) and some props (last year's Xmas tree, a radio from the 1980's and a rusty bike) will all contribute to a more authentic home-garage feel; proving that no professional help (i.e. commercial workshop/garage) was involved in the build. Of course, feel free to have yourself working away on the kit in the photos if one of your 'extras' can be trusted with the camera (not the cat; they never get the exposure right).

Finally, we know you haven't started yet, but we need to tell you about the Post Build Inspection now, due to availability at our service centres and the time it takes to get you a slot. Plan ahead!

What is the Post Build Inspection? This is a free service offered by all Caterham service centres which we wholeheartedly recommend you take up on prior to your IVA test. It ensures that your car is correctly assembled and is road-worthy. All safety and operational aspects of your Seven will be checked, concluding in a road test. This will enable us to advise you of any corrective work that may be required (which we will be happy to carry out for you\*). It is important to note that this is not the same as the IVA test and whilst every effort will be made to ensure your car passes, there is **NO GUARANTEE** of a first time IVA pass.

\*Obviously any additional work is not for free, but we will speak to you first so you can decide whether you want to pay us to do the corrections or you want to do them yourself.

**REMEMBER: Post Build Inspection slots are in high demand at our service centres and there may be a two-month lead time at busy times, so please check on availability and book ahead!**

All our service centres will be able to offer you a Post Build Inspection and IVA service, where they take the car to IVA on your behalf. This tends to increase the likelihood of a first time pass and means you don't need to take a day out to endure the test, which is beyond dull.

That's it, we're ready to start assembly

**ENJOY**

## MY BUILD NOTES

---

Download the IVA Checklist Guide: [www.caterhamcars.com](http://www.caterhamcars.com)

Book IVA Test

Take plenty of photos

Arrange post build check

*This was more fun than I ever expected!*

## HINTS & TIPS

When using a torque wrench, listen/feel the click and then stop. It does not need to be any tighter and you might actually weaken the fixing by 'over-torquing' it. Always wind your torque wrench setting back to free when you've finished with it.

**John K**

A 'nyloc' nut is one with a nylon insert that gets cut by the bolt thread, making it resistant to unwinding itself. This means that they should not be repeatedly re-used.

**Chris B**

This guide covers optional equipment your car may not have!

**Tiago O**

1Nm of torque equals 0.736lbft.

**Mick F**

Thread lock is used to stop something coming undone, but it only needs a little drop on the thread to be effective.

**Jamie A**

When using a spanner, always use the ring end wherever possible. The open end is really only for those times that access is too limited for a ring spanner or socket.

**Mick A**

Generally, metric Nyloc nuts have a blue nylon insert and imperial ones a white nylon insert.

**Grant P**

Teabag, boiling water, then the milk, in that order.

**Simon L**

Left and right are as viewed from the driver's seat.

**Harrison P**

You can tell if you have 'wide track suspension' car by looking at the front dampers. Wide track has a 25mm long hexagonal spacer between the top spring retainer and the mounting bush.

**Matt T**

A 'caphead bolt' has a circular head with a hexagonal drive inside it. It is tightened with an allen key or hex drive socket. Capheads are useful where there is limited space around the head for a spanner or socket. They look nice too!

**Richard T**

A bolt size is described by its diameter (e.g. M10=10mm) by the length not including the head (e.g. 65mm).

**James A**

A 'spring washer' has a split in it and squashes up closed when a fixing is tightened. It is usually used under a bolt head to help resist it coming undone.

**John S**





Speak to an expert  
[buildsupport@caterham.com](mailto:buildsupport@caterham.com)

# KEY

## SYMBOLS

**1** Item number

**AA**  
**AJ**  
**AM** Fixing item

**S** **R** S Pack / R Pack specific instructions

**Nm** Required torque (where applicable)

**S3**  
**S5** S3 / S5 chassis specific instructions

**REPEAT** Repeat on other side









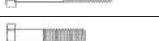

 Advice from factory professionals

 Now is a good time to take some photos

 Reminder to apply for your IVA test

 Refer to IVA Checklist Guide

## FIXINGS

Pack A		CATERHAM		44	
		PACK NUMBER		38F015B	
FRONT SUSPENSION DeDION CARS (METRIC)					
This pack may include extra fasteners to cover different options					
ITEM	BASIC DESCRIPTION	PART NUMBER	QTY	USED ON	ILLUSTRATION
1	AA Bolt M12 x 100 Grade 10.9	BM12X100	2	Lower wishbone rear	
2	AB Bolt M12 x 85 Grade 10.9	BM12X85	2	Lower wishbone front	
3	AC Bolt M10 x 85 Grade 10.9	BM10X85	2	Upper wishbone rear	
4	AD Bolt M10 x 80 Grade 10.9	BM10X80	2	Upper wishbone front	
5	AE Bolt M8 x 40 Grade 10.9	BM8X40	4	Anti-roll bar mounting brackets	
6	AF Plain Nut M14 x 1.5 thread	NM14	1	Temporary use to help lock upper wishbone ball joint	
7	AG Nyloc Nut M12	NM12	2	Lower wishbone rear	
8	AH Nyloc Nut M10	NM10	4	Upper wishbone	
9	AI Plain Washer M12 Dished	WPCM12	18	Lower wishbone	
AK	Plain Washer M8 Heavy Duty	WPH8	4	Anti-roll bar mounting brackets	
AL	Plain Washer M8 x 22 Heavy Duty	WPH22	2	Steering pipe	

ITEM	BASIC DESCRIPTION	PART NUMBER	QTY	USED ON	ILLUSTRATION
1	AA Bolt M12 x 100 Grade 10.9	BM12X100	2	Lower wishbone rear	

x4 ← (Indicates number of each fixing required)

← (Greyed out area indicates fixings are not required for current step)

# KEY

## TOOLS

	Adjustable spanner		Engine hoist		Power adhesive		Spanner		Torque wrench
	Allen key		Flat head screwdriver		Pozidrive screwdriver		Spirit level		Torx
	Assistance		Grease		Ruler		Spray adhesive		Trolley jack
	Axle stand		Junior hacksaw		Scissors		Spray lube		WD40
	Cable tie		Latex gloves		Side cutters		Stanley knife		
	Combination spanner		Long nose pliers		Silicon		Super glue		
	Copper grease		Marker Pen		Silicon gun		Tape		
	Drill		Muscle		Socket wrench		Tape measure		
	Drill bit		Pop rivet gun		Socket wrench (allen)		Thread lock / LocTite		

# LET'S GET READY

## PARTS

## TOOLS

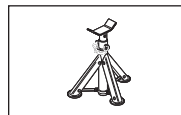

x3

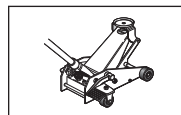

## FIXINGS

## TIPS

*When deciding how high your axle stands should be (the higher the better for working on), don't forget that a complete car will need to come down off them, so make sure your trolley jack can reach and lift the height you set them too!*

**Mick F**

*Some tape or foam on the top of the axle stands will stop them scratching the chassis.*

**Matt T**

# LET'S GET READY

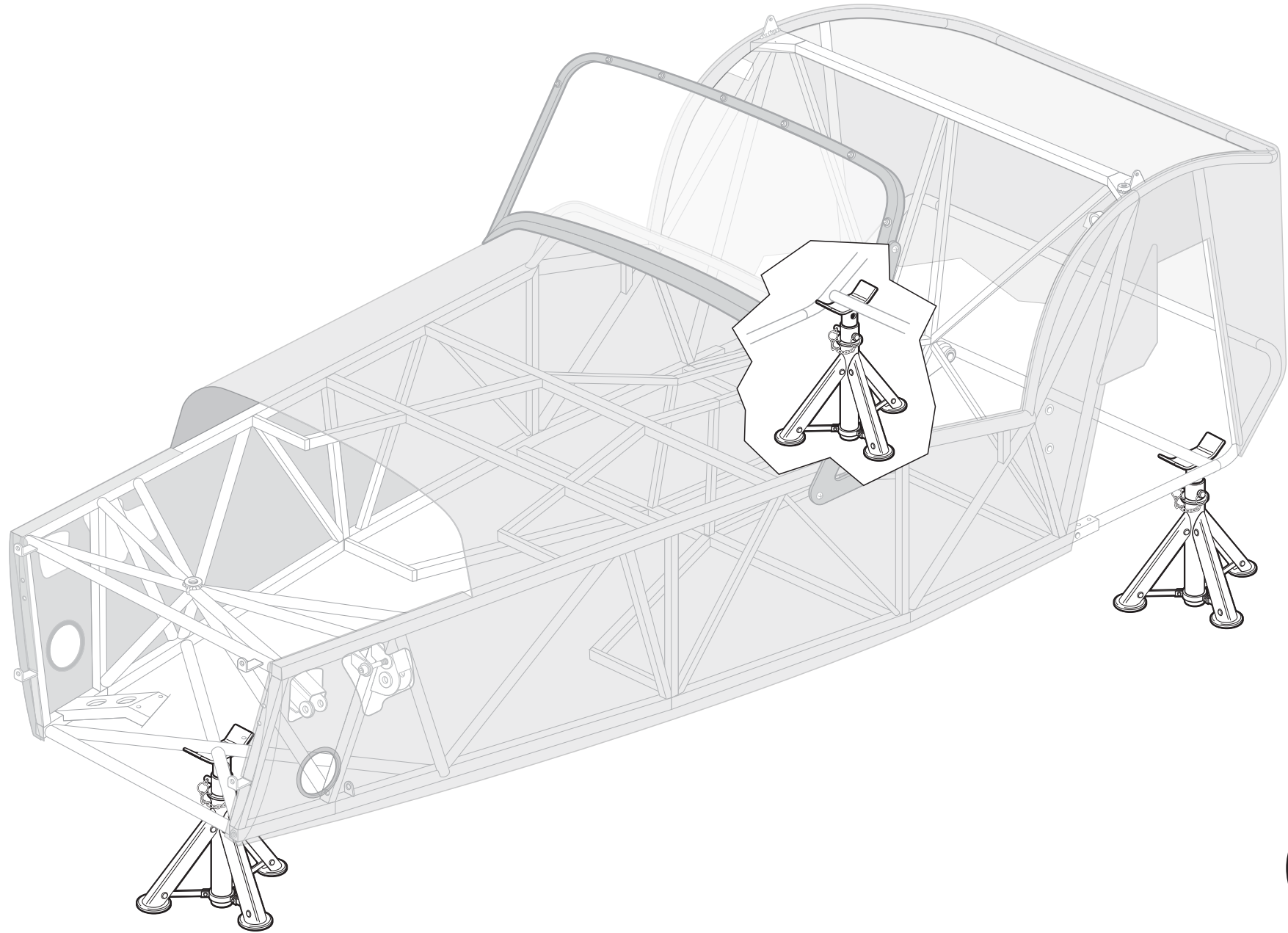

# START WITH THE SUSPENSION WISHBONES

## PARTS

- 1 Lower wishbone
- 2 Upper wishbone
- 3 Wishbone bush sleeve

## TOOLS

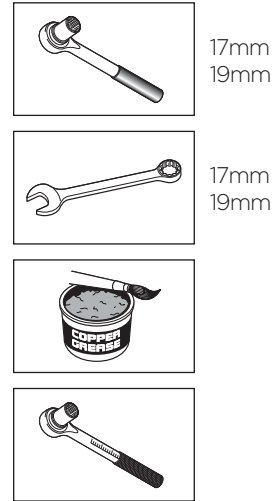

## FIXINGS

Pack <b>A</b>		<b>CATERHAM</b>		44	
		PART NUMBER		30F015B	
FRONT SUSPENSION DeDION CARS (METRIC)					
This pack may include extra fasteners to cover different options					
ITEM	BASIC DESCRIPTION	PART NUMBER	QTY	USED ON	ILLUSTRATION
1	Bolt M12 x 100 Grade 10.9	BM12X100	2	Lower wishbone rear	
2	Bolt M12 x 65 Grade 10.9	BM12X65	2	Lower wishbone front	
3	Bolt M10 x 65 Grade 10.9	BM10X65	2	Upper wishbone rear	
4	Bolt M10 x 60 Grade 10.9	BM10X60	2	Upper wishbone front	
5	Bush M8 x 60 Grade 10.9	BM8X60	4	Anti-roll bar mounting brackets	
6	Flan Nut M12 x 1.5 Thread	NM12F1.5	1	Temporary use to fit the lower upper wishbone ball joint	
7	Nylon Nut M12	NM12F12	2	Lower wishbone rear	
8	Nylon Nut M10	NM10F10	4	Upper wishbone	
9	Flan Washer M12 Overhead	WPM12	18	Lower wishbone	
10	Flan Washer M8 Overhead	WPM8	4	Anti-roll bar mounting brackets	
11	Flan Washer 1/2" x 1/2" Overhead	WPM1/2	2	Brake pipe	

Pack <b>A</b>		<b>CATERHAM</b>		44	
		PART NUMBER		30F015B	
FRONT SUSPENSION DeDION CARS (METRIC)					
This pack may include extra fasteners to cover different options					
ITEM	BASIC DESCRIPTION	PART NUMBER	QTY	USED ON	ILLUSTRATION
12	Spring Washer M12	WSM12	2	Lower wishbone front	
13	Spring Washer M8	WSM8	4	Anti-roll bar mounting brackets & upper damper rodent	
14	Washer 1/2" Brake pipe	WPM1/2	2	Brake pipe	
15	Nylon Nut 1/2" Headlight	NM1/2F1/2	2	Wing stay	
16	Nylon Nut 1/2" Headlight	NM1/2F1/2	2	Front brake, spring mounting (old track)	

x2

x2

x2

x2

x2

x4

x14

x2

## TIPS

For now, only tighten the nuts/bolts lightly and then torque them up when the car is finished and on the ground. This sets the bushes correctly and ensures the best handling.

**Harrison P**

The big washers are chamfered and the chamfered side should be towards the wishbone.

**Alex H**

Leave bolt AD loose for now, as we have to take it back out again to put the headlight bracket on later.

**John K**

# START WITH THE SUSPENSION WISHBONES

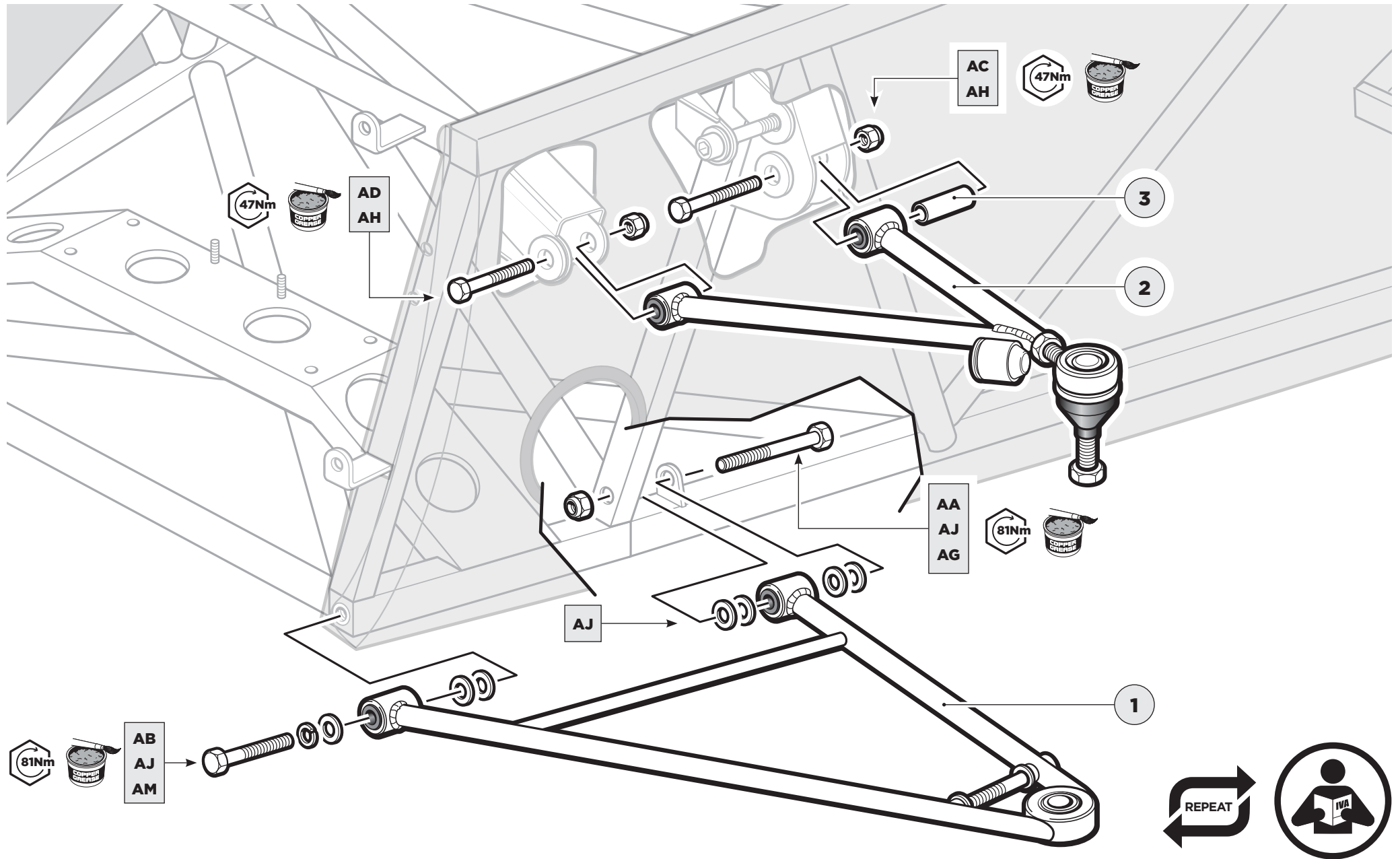

# NOW FOR THE STEERING RACK

## PARTS

- 1 Steering rack
- 2 Rack clamps
- 3 Column universal joint
- 4 Track rod end
- 5 IVA cover

## TOOLS



13mm

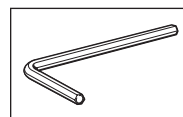
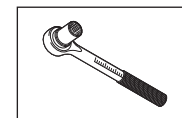

5mm

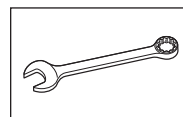

10mm  
13mm  
22mm  
3/4"

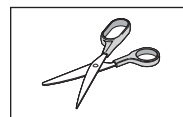

## FIXINGS

Pack B		CATERHAM		55	
		PACK NUMBER		JAC70021	
		RELEASED NOV-19			
STEERING DeDION CARS (METRIC)					
This pack may include extra fasteners to cover different options					
ITEM	BASIC DESCRIPTION	PART NUMBER	QTY	USED ON	ILLUSTRATION
1	Clamped Nut M8 x 70 DM142	BMCHEX70	4	Rack clamps	
2	Bolt 12 x 1.75	BF14X1.75	2	Column clamp	
3	Bolt M8 x 60 G10M-10.9	B8Mx60	2	Column to rack universal joint	
4	Washer Nut 12 (not used)	WPN12	1	Steering wheel boss	
5	Plain Nut 12	NPN12	2	Track rod lock nut	
6	Plain Nut 10 (not used)	NPN10	1	Column clamp (not used)	
7	Nyloc Nut M8	NMY8	2	Column to rack universal joint	
8	Nyloc Nut M8	NMY8	4	Steering rack clamps	
9	Plain Washer 12 (not used)	WPN12	1	Steering wheel boss	
10	Plain Washer 12 Heavy Duty	WPH14	6	Rack clamps and column clamp	
11	Spring Washer 12 Heavy Duty	WSP14	2	Column clamp	

x4

x2

x2

x2

x4

x4

x4

## TIPS

Finding the right IVA cover isn't obvious because it is effectively a long cap. To use it, you cut the closed end off.

Jamie A

The trackrod end needs to screw on about 12 turns (it will be properly set later when the tracking is done).

Matthew H

Don't fully tighten steering rack for now.

Dan D

# NOW FOR THE STEERING RACK

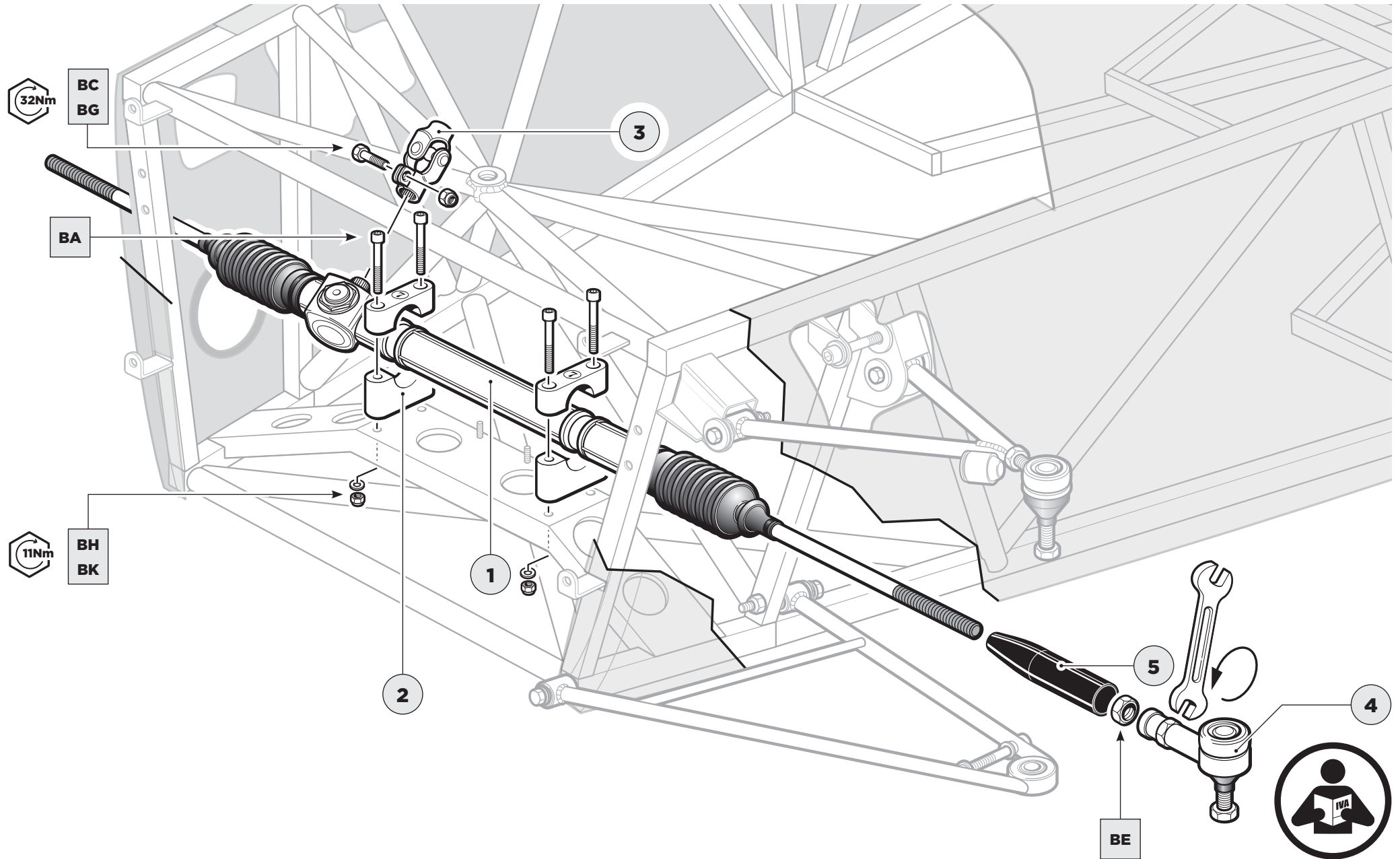

# AND THEN THE DAMPERS

## PARTS

- 1 Spring / damper
- 2 Lower damper sleeve
- 3 Upper damper sleeve

## TOOLS

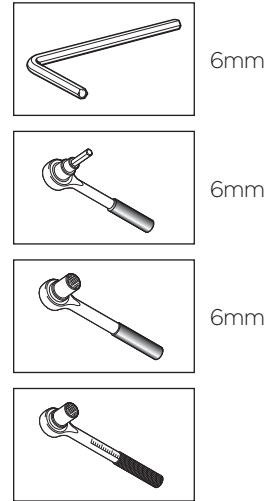

## FIXINGS

Pack <b>A</b>		<b>CATERHAM</b>		44	
		PACK NUMBER		30F015B	
FRONT SUSPENSION DeDION CARS (METRIC)					
This pack may include extra fasteners to cover different options					
ITEM	BASIC DESCRIPTION	PART NUMBER	QTY	USED ON	ILLUSTRATION
1	Ball M12 x 100 DIN913	8M12100	2	Lower wishbone rear	
2	Ball M12 x 60 DIN913	8M12060	2	Lower wishbone front	
3	Ball M12 x 60 DIN913	8M12060	2	Upper wishbone rear	
4	Ball M12 x 60 DIN913	8M12060	2	Upper wishbone front	
5	Ball M8 x 40 DIN913	8M0840	4	Anti-roll bar mounting brackets	
6	Plan No 8514 x 1.2 thread	8M0914	1	Temporary use to temporarily upper wishbone ball joint	
7	Nylon Nut M12	8M0712	2	Lower wishbone rear	
8	Nylon Nut M12	8M0712	4	Upper wishbone	
9	Plan Washer M12 DIN913	8M0812	18	Lower wishbone	
10	Plan Washer M8 DIN913	8M0808	4	Anti-roll bar mounting brackets	
11	Plan Washer 1/2" x 1/2" DIN913	8M0808	2	Brake pipe	

Drawings are for illustrative purposes only and are not to scale. Page 1 of 2

Pack <b>A</b>		<b>CATERHAM</b>		44	
		PACK NUMBER		30F015B	
FRONT SUSPENSION DeDION CARS (METRIC)					
This pack may include extra fasteners to cover different options					
ITEM	BASIC DESCRIPTION	PART NUMBER	QTY	USED ON	ILLUSTRATION
12	Spring Washer M12	8M0812	2	Lower wishbone rear	
13	Spring Washer M8	8M0808	6	Anti-roll bar mounting brackets & upper damper mount	
14	Washer 1/2" DIN913	8M0808	2	Brake pipe	
15	Nylon Nut 1/2" DIN913	8M0712	2	Wing stay	
16	Nylon Nut 1/2" DIN913	8M0712	2	Front brake, spring mounting (old track rod)	

Drawings are for illustrative purposes only and are not to scale. Page 2 of 2

Fixings not contained in the pack will be supplied loosely fitted to the chassis and the wishbone

## TIPS

Put the top of the damper on first and be careful not to let it swing into the side of the chassis.

Grant P

The bottom can be a tight fit!

Mick F

# AND THEN THE DAMPERS

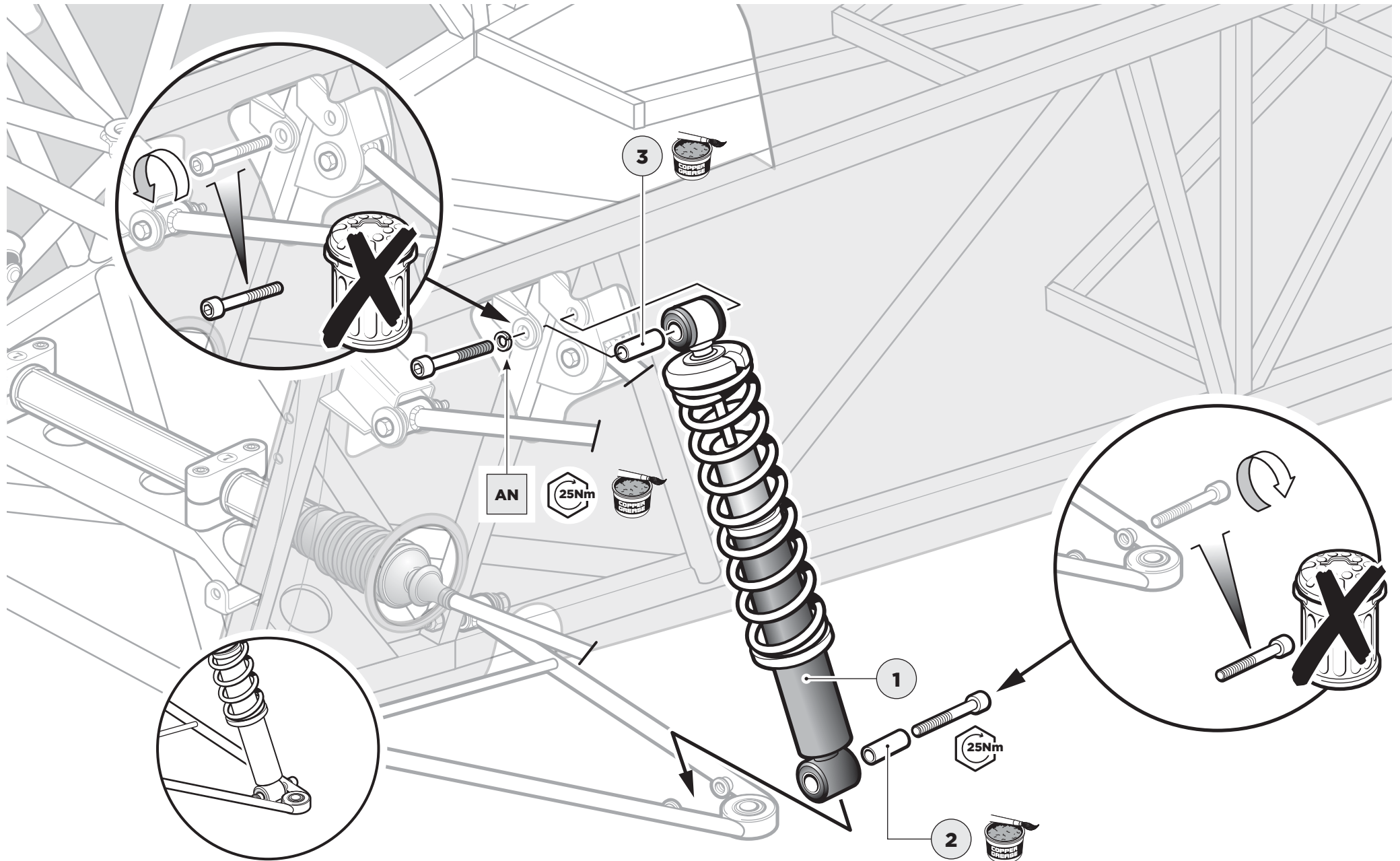

# IT'S TIME FOR THE WINGSTAYS

## PARTS

- 1 Wingstay
- 2 Front brake & upright assembly

## TOOLS

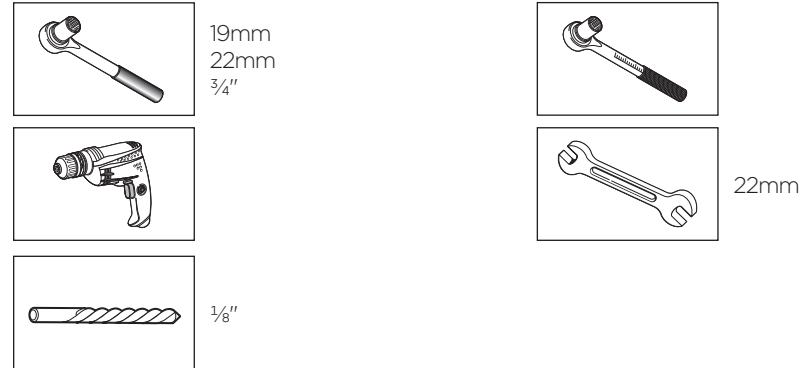

## FIXINGS

Pack <b>A</b>		<b>CATERHAM</b>		PART NUMBER: 30F015B	
FRONT SUSPENSION DeDION CARS (METRIC)					
ITEM	BASIC DESCRIPTION	PART NUMBER	QTY	USED ON	ILLUSTRATION
1	AA Bolt M12 x 95 (Metric)	8M12150	2	Lower wishbone rear	
2	AE Bolt M12 x 65 (Metric)	8M12060	2	Lower wishbone front	
3	AC Bolt M12 x 65 (Metric)	8M12060	2	Upper wishbone rear	
4	AD Bolt M12 x 65 (Metric)	8M12060	2	Upper wishbone front	
5	AE Bolt M8 x 40 (Metric)	8M08040	4	Anti-roll bar mounting brackets	
6	AF Plain Nut M14 x 1.5 thread	8M1414	1	Temporary use to help lock upper wishbone ball joint	
7	AG Nylon Nut M12	8M1212	2	Lower wishbone rear	
8	AH Nylon Nut M12	8M1212	4	Upper wishbone	
9	AJ Plain Washer M12 (Metric)	8W1212	18	Lower wishbone	
10	AK Plain Washer M8 (Metric)	8W0808	4	Anti-roll bar mounting brackets	
11	AL Plain Washer 1/2" x 1/2" (Imperial)	8W1616	2	Brake pipe	

Drawings are for illustrative purposes only and are not to scale. Page 1 of 2

Pack <b>A</b>		<b>CATERHAM</b>		PART NUMBER: 30F015B	
FRONT SUSPENSION DeDION CARS (METRIC)					
ITEM	BASIC DESCRIPTION	PART NUMBER	QTY	USED ON	ILLUSTRATION
12	AM Spring Washer 16T	8W1612	2	Lower wishbone rear	
13	AN Spring Washer 16T	8W1612	6	Universal bar mounting brackets & upper damper mount	
14	AP Washer 1/2" (Imperial)	8W1616	2	Brake pipe	
15	AR Nylon Nut 1/2" (Imperial)	8W1612	2	Wing stay	
16	AS Nylon Nut 1/2" (Imperial)	8W1612	2	Front brake, upright mounting (std track ONLY)	

Drawings are for illustrative purposes only and are not to scale. Page 2 of 2

x2  
x2

## TIPS

The drilled hole is for the side repeater earth that we'll fit later. It's easier to drill from the top and down through both sides of the tube, rather than through one side from the bottom (where the earth will be fixed).

Tiago O

Put the 'upright' into the lower wishbone joint then attach the steering before tightening the bottom nut. This stops it all swinging around hitting the side of the chassis.

John S

Some of the fixings required and shown on the drawings, such as the ball joint nut, are already on the part and not in the fixing pack.

Anthony L

Remove and discard the washer that comes on the back of the assembly before fitting the wingstay; it's not needed.

Rich T

Use the plain nut to pull the top ball joint home before using a nyloc, otherwise the thread will spin.

Chris N

# IT'S TIME FOR THE WINGSTAYS

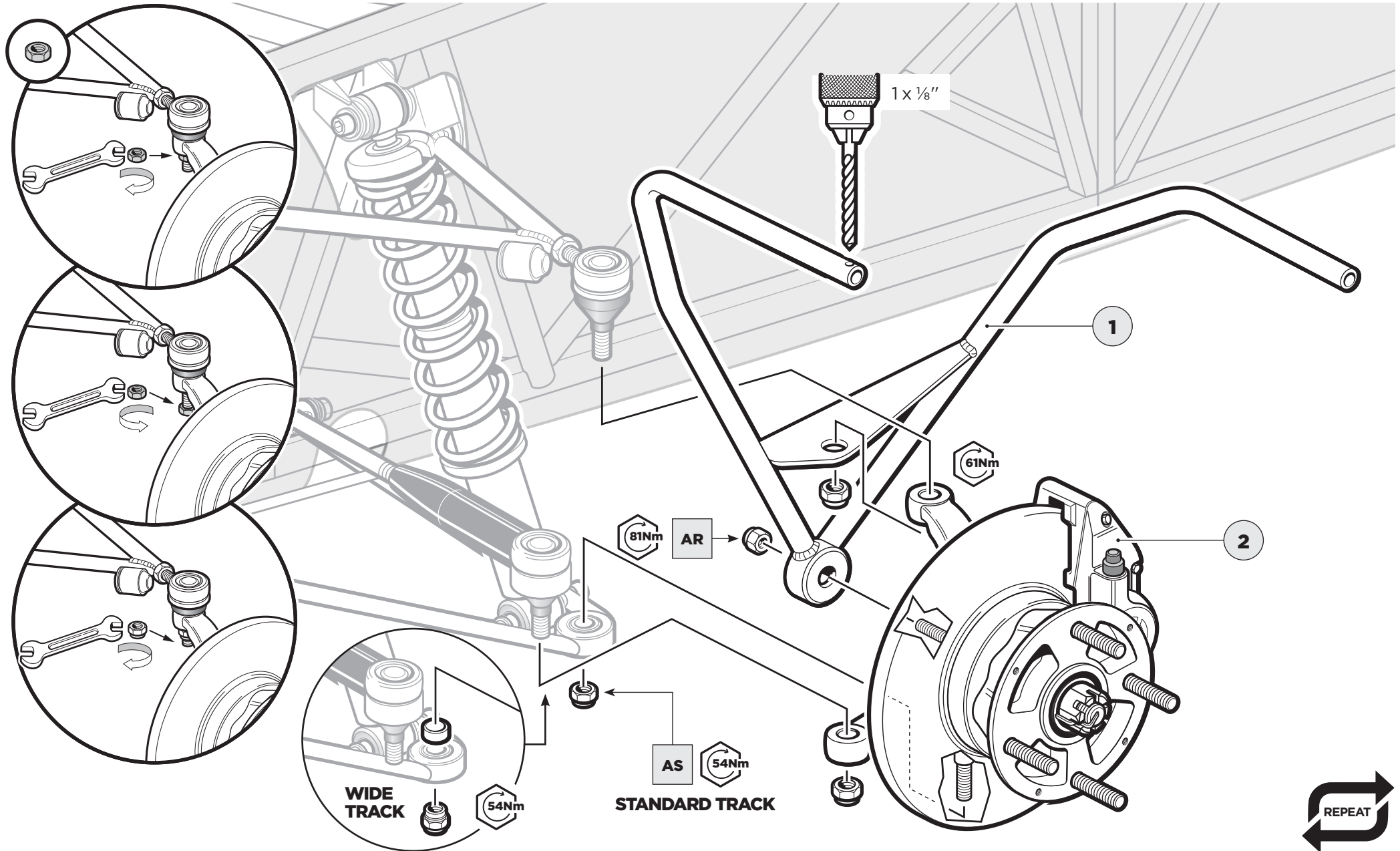



*Now is a good time to take some photos*



Have you applied for your IVA yet?

# LET THERE BE LIGHTS

## PARTS

- 1 Headlight assembly
- 2 Indicator pod
- 3 Indicator assembly
- 4 Headlight bracket
- 5 IVA trim

## TOOLS

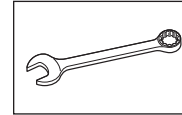
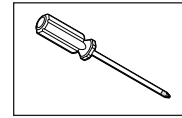

17mm  
24mm

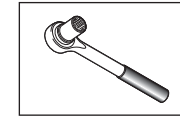

17mm

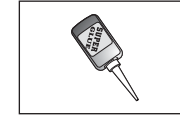

17mm

## FIXINGS

Pack C		CATERHAM		45	
		PACK NUMBER		30L002B	
LIGHTING & HORNS					
ITEM	BASIC DESCRIPTION	PART NUMBER	QTY	USED ON	ILLUSTRATION
1	Screw 10 x 1" (25mm)	F1080	6	Indicator assembly to indicator pod	
2	Screw 8 x 1" (25mm)	F1071	2	Side regulator earth on wing/body	
3	Screw 12 x 1" (30mm)	F1072	4	Rear light cluster upper fixing	
4	Screw 12 x 1" (30mm)	F1073	4	Rear light cluster lower fixing	
5	Wash Hex 100	H0170	2	Horn bracket to mounting plate (H0221010)	
6	Wash Washer 100	H0171	2	Horn bracket to mounting back plate (H0221010)	
7	Ball 100 x 10 (30mm)	H0172	1	Through steering rack column at motor (H02)	
8	Wash Washer 100	H0173	2	Ball Head/hut	
9	Wash Hex 100	H0174	1	Horn base	

Drawings are for illustrative purposes only and are not to scale. Page 1 of 1

x6

## TIPS

It's very important to read the IVA Guide before starting this job to ensure grommets and sheathing are in the right place. It's very difficult to add them once fitted!

John S

This is the trickiest job on the car, so once done you can breathe a sigh of relief!

Tiago A

The wiring for the headlights is attached to the chassis when you receive your kit. The wires go through the hole in the end of the headlight bracket and out of the other hole in order to go up into the headlight and over to the indicator.

Jamie A

Glue IVA trim all around the edge of the pod before fitting.

Chris B

The tab on the headlight bracket ④ hooks under the wishbone bracket on the chassis.

Harrison P

# LET THERE BE LIGHTS

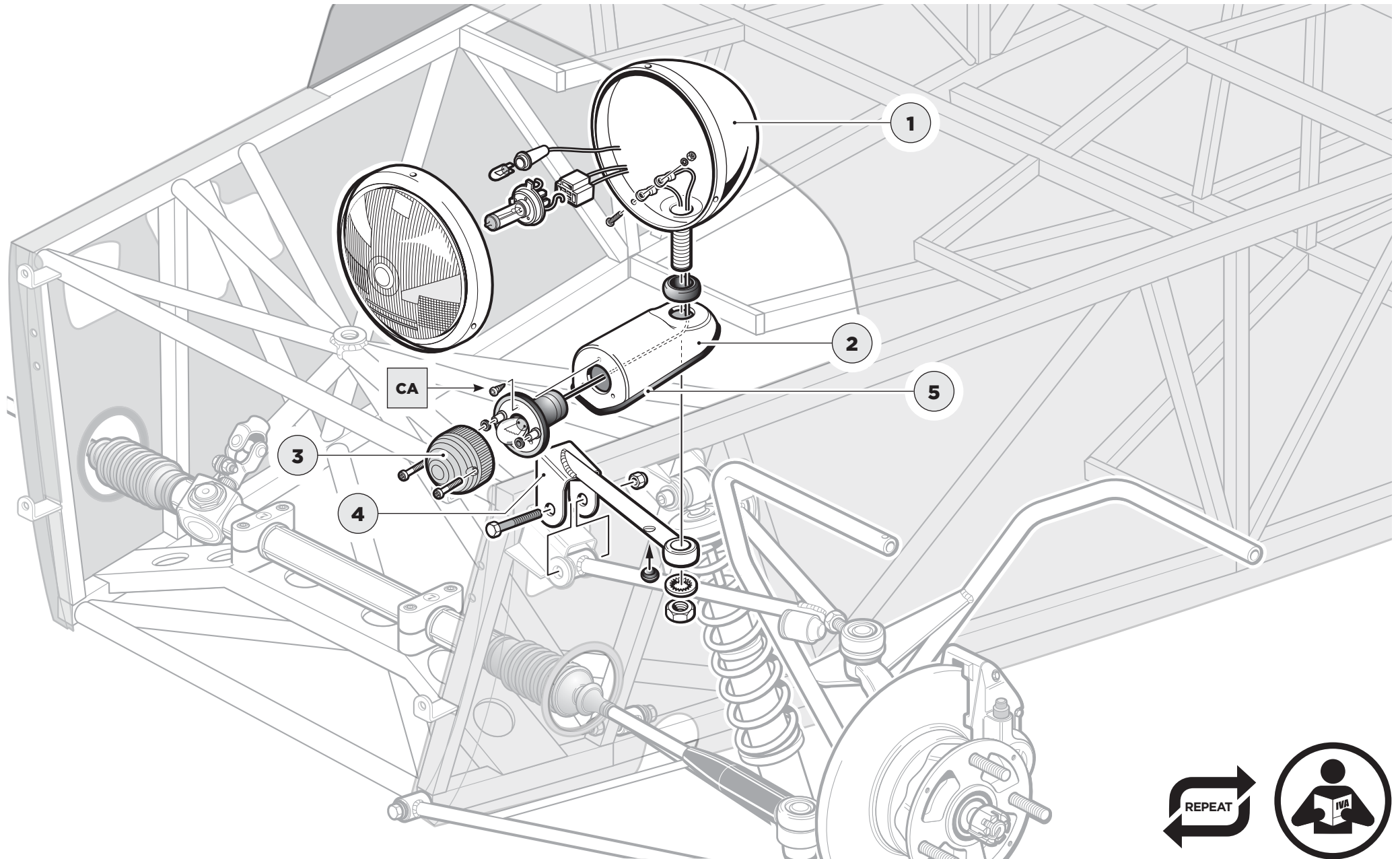

# LAST PART OF THE FRONT SUSPENSION: CONNECTING THE TWO SIDES TOGETHER

## PARTS

- 1 Anti-roll bar
- 2 Anti-roll bar bracket
- 3 Anti-roll bar rubber
- 4 Anti-roll bar ball
- 5 Anti-roll bar dust cover

## TOOLS

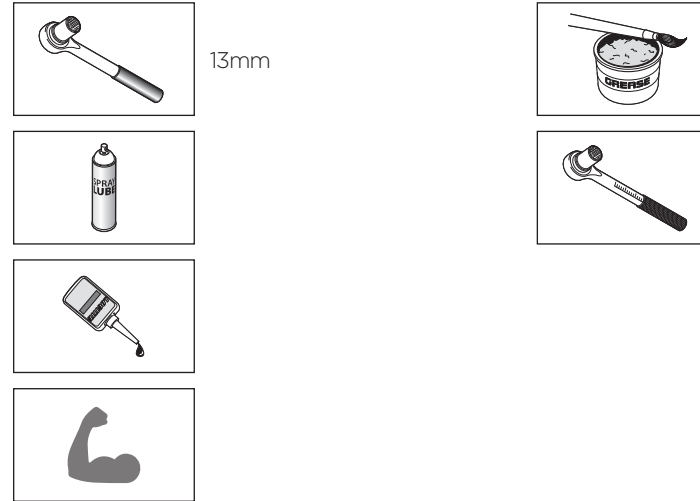

## FIXINGS

ITEM	BASIC DESCRIPTION	PART NUMBER	QTY	USED ON	ILLUSTRATION
1	AA Bolt M12 x 100 (Prepainted)	BM12100	2	Lower wishbone rear	
2	AE Bolt M12 x 60 (Prepainted)	BM12060	2	Lower wishbone front	
3	AG Bolt M12 x 60 (Prepainted)	BM12060	2	Upper wishbone rear	
4	AG Bolt M12 x 60 (Prepainted)	BM12060	2	Upper wishbone front	
5	AE Bolt M6 x 40 (Prepainted)	BM640	4	Anti-roll bar mounting brackets	
6	AP Plain Nut M12 x 1.5 Thread	BM1215	1	Temporary use to help lock upper wishbone ball joint	
7	AG Nylon Nut M12	BM1212	2	Lower wishbone rear	
8	AG Nylon Nut M12	BM1212	4	Upper wishbone	
9	AJ Plain Washer M12 (Prepainted)	BM1212	18	Lower wishbone	
10	AK Plain Washer M6 Heavy Duty	BM648	4	Anti-roll bar mounting brackets	
11	AL Plain Washer 12 x 12 (Prepainted)	BM1212	2	Brake pads	

Drawings are for illustrative purposes only and are not to scale. Page 1 of 2

ITEM	BASIC DESCRIPTION	PART NUMBER	QTY	USED ON	ILLUSTRATION
12	AM Spring Washer M12	BM1212	2	Lower wishbone rear	
13	AN Spring Washer M6	BM618	6	Anti-roll bar mounting brackets & upper damper mount	
14	AP Washer 12 (Prepainted)	BM1212	2	Brake pads	
15	AR Nylon Nut 12 (Prepainted)	BM1212	2	Wing stay	
16	AS Nylon Nut 12 (Prepainted)	BM1212	2	Front brake, spring mounting (old track pads)	

Drawings are for illustrative purposes only and are not to scale. Page 2 of 2

x4

x4

x4

## TIPS

Use four small cable ties to secure the dust cover.

**Mick F**

Grease the balls and cups generously.

**Matt T**

Check that the colour of the mounting rubbers matches the colour spot on the bar.

**John K**

Use the thread lock on the thread of the anti-roll bar, not in the thread of the ball.

**Dan D**

Getting the assembled anti-roll bar fully into both cups on the upper wishbone can be a bit of a fight. It's made of springy stuff, so don't worry that you are bending it.

**Jamie A**

## LAST PART OF THE FRONT SUSPENSION: CONNECTING THE TWO SIDES TOGETHER

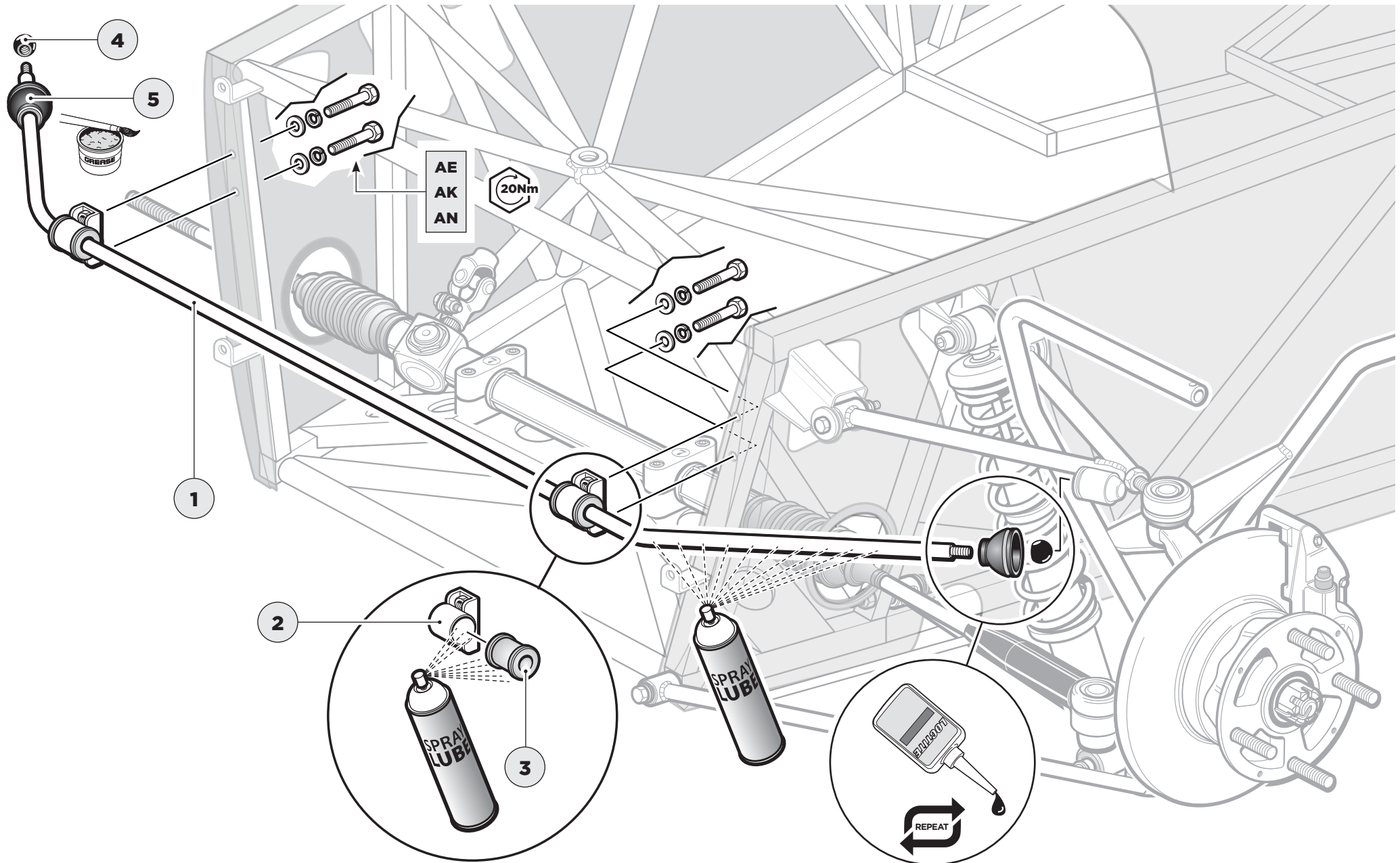

# FITTING THE BRAKE HOSES

## PARTS

- 1 Brake hose
- 2 Copper washer

## TOOLS

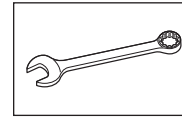

13mm (x2)  
9/16"

## FIXINGS

Pack A		CATERHAM		44	
		PACK NUMBER		30F015B	
FRONT SUSPENSION DeDION CARS (METRIC)					
This pack may include extra fasteners to cover different options					
ITEM	BASIC DESCRIPTION	PART NUMBER	QTY	USED ON	ILLUSTRATION
1	AA Bush M12 x 60 (Metric)	BA122100	2	Lower wishbone rear	
2	AE Bush M12 x 60 (Metric)	BA122090	2	Lower wishbone front	
3	AC Bush M12 x 60 (Metric)	BA122080	2	Upper wishbone rear	
4	AD Bush M12 x 60 (Metric)	BA122070	2	Upper wishbone front	
5	AE Bush M8 x 40 (Metric)	BA08200	4	Anti-roll bar mounting brackets	
6	AF Plan No M14 x 1.5 Thread	BA09110	1	Temporary use to fit the front upper wishbone ball joint	
7	AG Nylon Nut M12	BA09112	2	Lower wishbone rear	
8	AH Nylon Nut M12	BA09110	4	Upper wishbone	
9	AJ Plain Washer M12 (Oversize)	WP0312	18	Lower wishbone	
10	AK Plain Washer M8 (Metric)	WP0308	4	Anti-roll bar mounting brackets	
11	AL Plain Washer 1/2" x 1/2" Heavy Duty	WP0308	2	Brake pipe	

Drawings are for illustrative purposes only and are not to scale. Page 1 of 2

Pack A		CATERHAM		44	
		PACK NUMBER		30F015B	
FRONT SUSPENSION DeDION CARS (METRIC)					
This pack may include extra fasteners to cover different options					
ITEM	BASIC DESCRIPTION	PART NUMBER	QTY	USED ON	ILLUSTRATION
12	AM Spring Washer M12	WSP012	2	Lower wishbone rear	
13	AN Spring Washer M8	WSP008	6	Anti-roll bar mounting brackets & upper damper shock	
14	AP Washer 1/2" Brake steel	WSP018	2	Brake pipe	
15	AR Nylon Nut 1/2" (Metric)	WSP112	2	Wing stay	
16	AS Nylon Nut 1/2" (Metric)	WSP112	2	Front brake, spring mounting (old track)	

Drawings are for illustrative purposes only and are not to scale. Page 2 of 2

x2

x2

## TIPS

The hose will want to curve once fitted. Make sure the curve points towards the front of the car.  
**Khalfani D**

Brake hoses come in packs of 3: 2 front, 1 back.  
**Anthony L**

The copper washer should be this size.  
**James A**

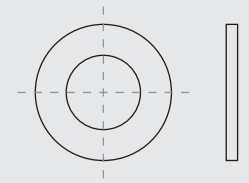

## FITTING THE BRAKE HOSES

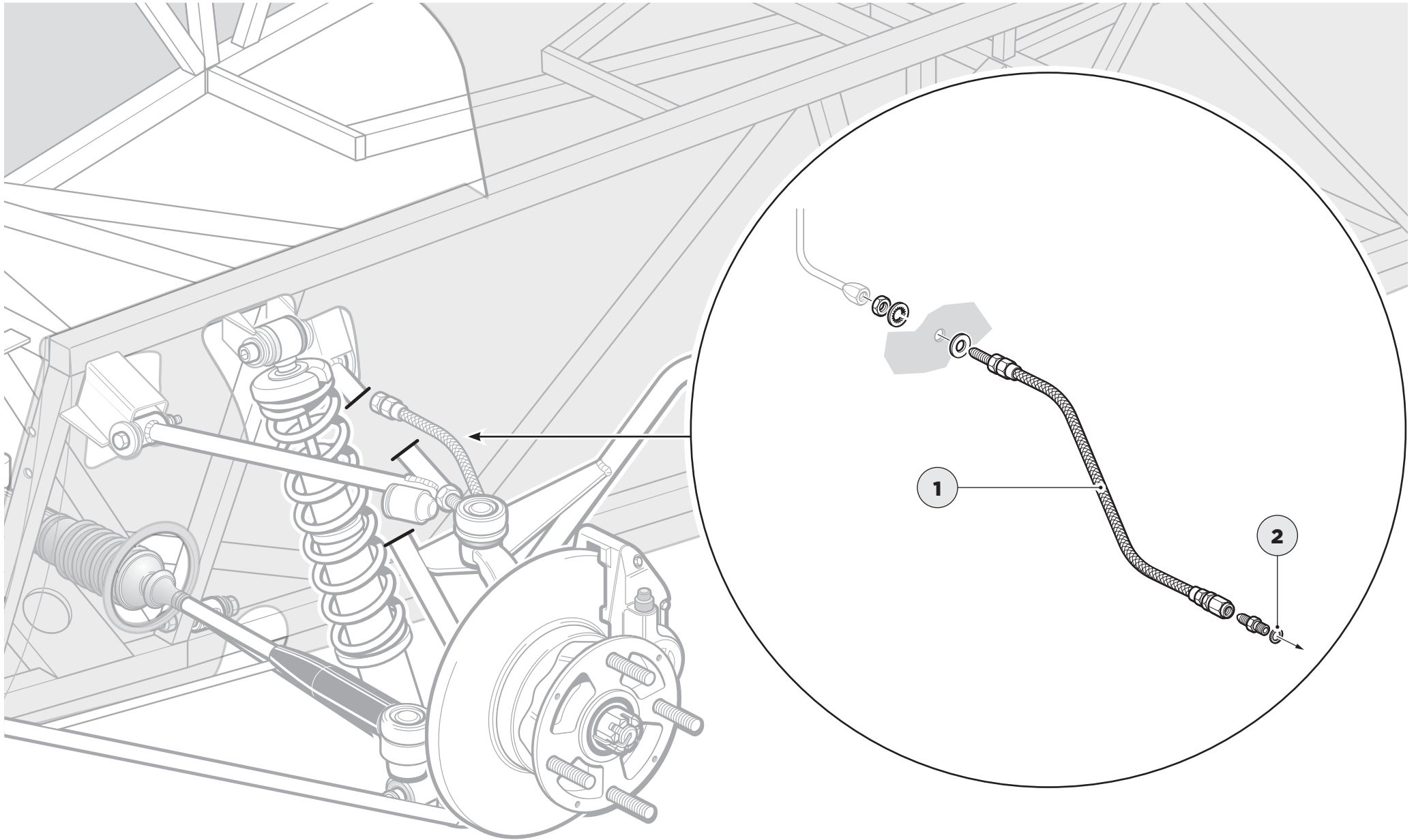

## LET'S MAKE SOME NOISE

### PARTS

- 1 Horn kit (x2)
- 2 Spacer (miscellaneous box)
- 3 Bolt for spacer

### TOOLS



10mm

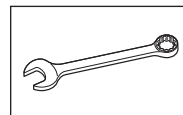

13mm

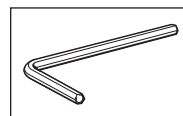

6mm

### FIXINGS

Miscellaneous box

### TIPS

270/310/360

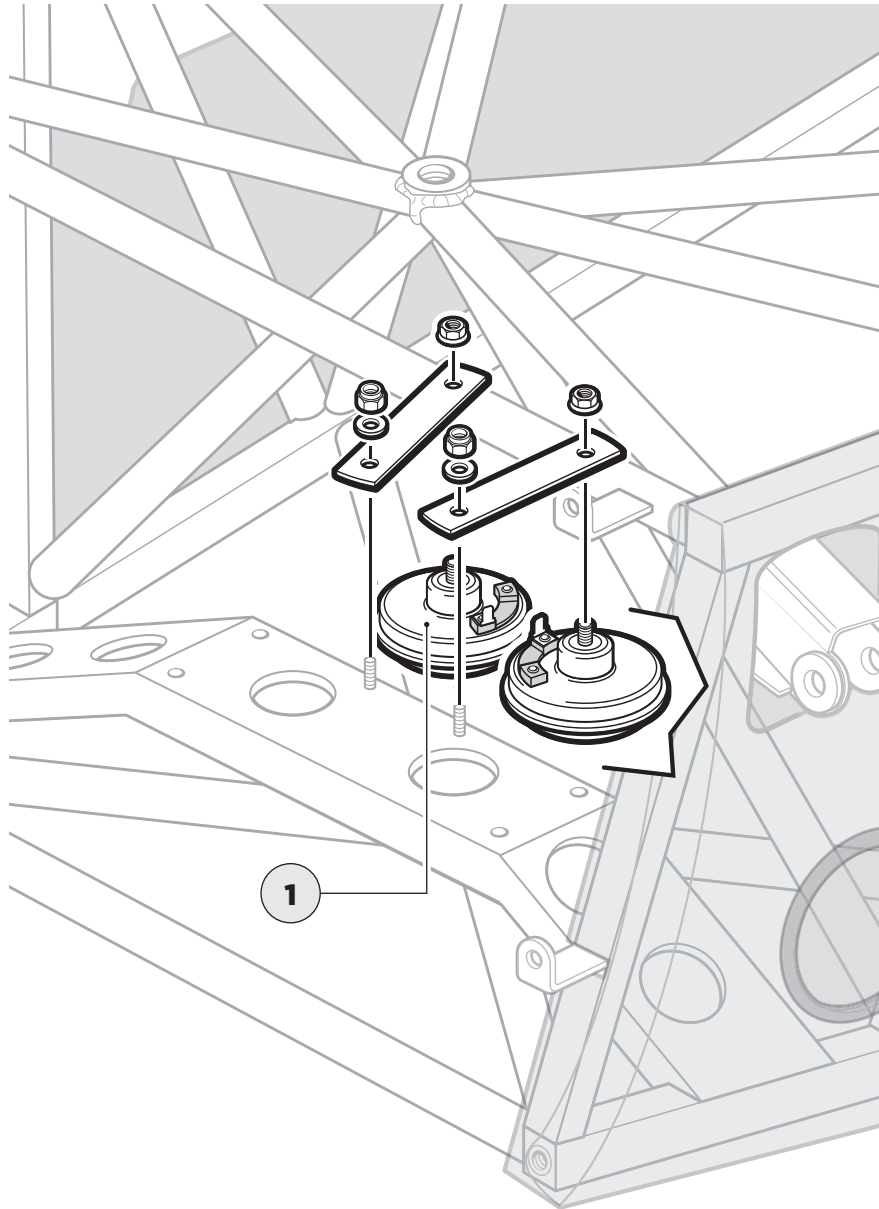

420

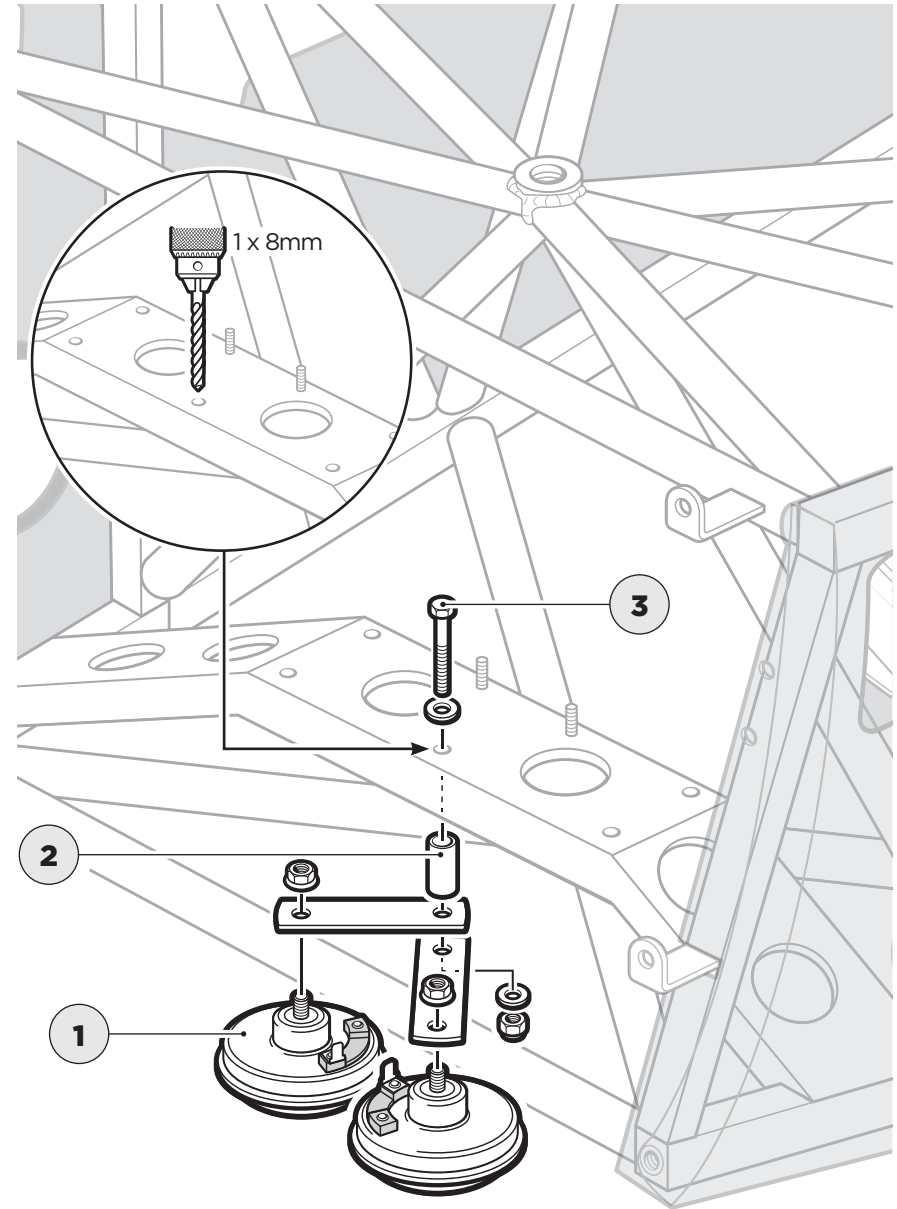

# WET SUMP FITTING THE RADIATOR

## PARTS

- 1 Radiator
- 2 Blanking plate
- 3 Fan
- 4 Radiator bobbins

## TOOLS

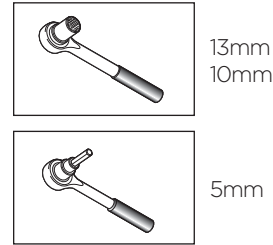

## FIXINGS

Pack D		CATERHAM		44	
		PACK NUMBER		SIZES/ITS	
COOLING SIGMA					
This pack may include extra fasteners to cover different options					
ITEM	BASIC DESCRIPTION	PART NUMBER	QTY	USED ON	ILLUSTRATION
1	DA Nut M8 x 20 Heavy Duty	888440	1	Expansion tank bracket to chassis	
2	DB Bolt M8 x 16 Heavy Duty	88714024	1	Expansion tank to bracket	
3	DC Bolt M8 x 20 Heavy Duty	888420	4	SM radiator bracket	
4	DD Nut M8 x 16 with Square Washer	88714024	4	Fan brackets to fan	
5	DE Bolt M8 x 16 Heavy Duty	88844010	4	Fan to radiator mounting to SM radiator	
6	DF Nylon Nut M8	NM9F8	8	4x Fan to radiator 4x SM radiator bracket	
7	DG Plain Nut M8	NM9F8	8	Radiator bobbin	
8	DH Nylon Nut M8	NM9F14	1	Expansion tank bracket	
9	DI Plain Washer 16 Heavy Duty	8891016	13	13 x DV Nut Bracket 4 x 4 Fan Brackets 1 x Expansion tank to chassis	
10	DJ Plain Washer 12 Heavy Duty	8891012	4	Radiator bobbin back	
11	DK Plain Washer 16 Heavy Duty	88911616	4	Radiator bobbin front	

Drawings are for illustrative purposes only and are not to scale. Page 1 of 2

x4

x4

x4

x4

Pack D		CATERHAM		44	
		PACK NUMBER		SIZES/ITS	
COOLING SIGMA					
This pack may include extra fasteners to cover different options					
ITEM	BASIC DESCRIPTION	PART NUMBER	QTY	USED ON	ILLUSTRATION
12	DL Plain Washer 16 Heavy Duty	88911616	1	Expansion tank bracket	
13	DM Spring Washer 16 Heavy Duty	8891016	5	5 x Radiator bobbin 1 x Expansion tank	
14	DN Hex Cap 16 Heavy	8872040	6	2 x 4 x DV Nut Bracket 4 x 4 Fan Brackets 2 x Expansion tank	
15	DO Hex Cap 16 Heavy	8872038	2	1 x Engine outlet to top 1 Engine 1 x Engine outlet to motor (top)	
16	DP Hex Cap 17 Heavy	8871625	18	18 x Fan Brackets 18 x Expansion tank 18 x DV Nut	
17	DI Hex Cap 16 Heavy	8871616	6	Expansion tank small 6 piece	
18	DR Hex Bolt 12 Heavy	8871612	12	Cooling fan	

Drawings are for illustrative purposes only and are not to scale. Page 1 of 2

## TIPS

Be careful to tighten the fan gently and with just a nip.

Dan P

The fan should have a 'flat' section on the rim. This should be at the top.

Grant P

The blanking plate is fitted using two M8X16 bolts, they should be in the box.

James A

# WET SUMP FITTING THE RADIATOR

WET SUMP

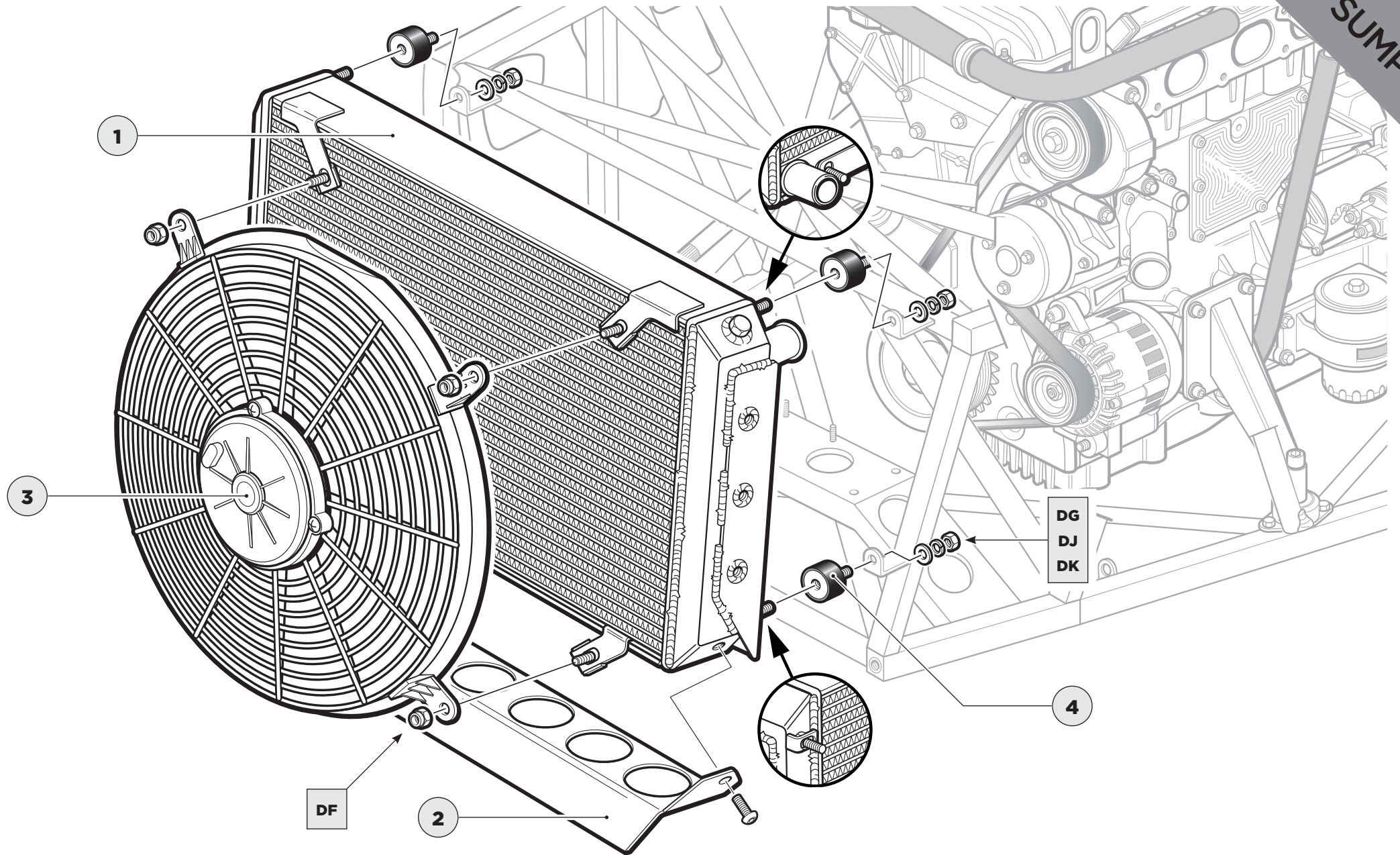

# DRY SUMP FITTING THE RADIATOR

## PARTS

- 1 Radiator
- 2 Blanking plate
- 3 Fan
- 4 Radiator bobbins

## TOOLS

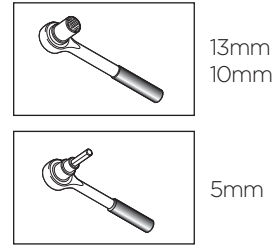

## FIXINGS

Pack D		CATERHAM		44	
		PACK NUMBER		SIZES/ITS	
<b>COOLING SIGMA</b>					
<i>This pack may include extra fasteners to cover different options</i>					
ITEM	BASIC DESCRIPTION	PART NUMBER	QTY	USED ON	ILLUSTRATION
1	DA Nut M8 x 20 Heavy Duty	888440	1	Expansion tank bracket to chassis	
2	DB Bolt M8 x 16 Heavy Duty	887142/4	1	Expansion tank to bracket	
3	DC Bolt M8 x 20 Heavy Duty	888420	4	SM radiator bracket	
4	DD Nut M8 x 16 with Square Section	887107/4	4	Fan brackets to fan	
5	DE Bolt M8 x 20 Heavy Duty	888420/10	4	Fan to radiator mounting to SM radiator bracket	
6	DF Nylon Nut M8	NM976	8	84 Fan to radiator bracket	
7	DG Plain Nut M8	NM978	8	Radiator bobbin	
8	DH Nylon Nut M8	NM974/4	1	Expansion tank bracket	
9	DI Plain Washer 16 Heavy Duty	889114	13	13 x 16 Fan Brackets 4 x 4 Expansion tank 1 x Expansion tank to chassis	
10	DJ Plain Washer 12 Heavy Duty	889116	4	Radiator bobbin back	
11	DK Plain Washer 12 Heavy Duty	889117/4	4	Radiator bobbin front	

Drawings are for illustrative purposes only and are not to scale. Page 1 of 2

x4

x4

x4

x4

Pack D		CATERHAM		44	
		PACK NUMBER		SIZES/ITS	
<b>COOLING SIGMA</b>					
<i>This pack may include extra fasteners to cover different options</i>					
ITEM	BASIC DESCRIPTION	PART NUMBER	QTY	USED ON	ILLUSTRATION
12	EL Plain Washer 16 Heavy Duty	889114/4	1	Expansion tank bracket	
13	EM Spring Washer 16 Heavy Duty	889101/2	8	8 x Radiator bobbin 1 x Expansion tank	
14	EN Hex Cap 16 Heavy	88720/40	6	2 x 16 where fan is used 2 x 16 radiator hose 2 x 16 where radiator hose	
15	EO Hex Cap 16 Heavy	88720/30	2	1 x Engine outlet to top 1 Engine 1 x Engine outlet to bottom 1 Engine	
16	EP Hex Cap 16 Heavy	88710/20	18	18 where radiator to fan 18 where radiator to fan 18 where radiator to fan	
17	EQ Hex Cap 16 Heavy	88710/10	6	Expansion tank small 1 piece	
18	ER Bolt - Black 12 x 16 Heavy Duty	88710/10/10	12	Cooling fan	

Drawings are for illustrative purposes only and are not to scale. Page 1 of 2

## TIPS

Be careful to tighten the fan gently and with just a nip.

Dan P

The fan should have a 'flat' section on the rim. This should be at the top.

Grant P

# DRY SUMP FITTING THE RADIATOR

DRY SUMP

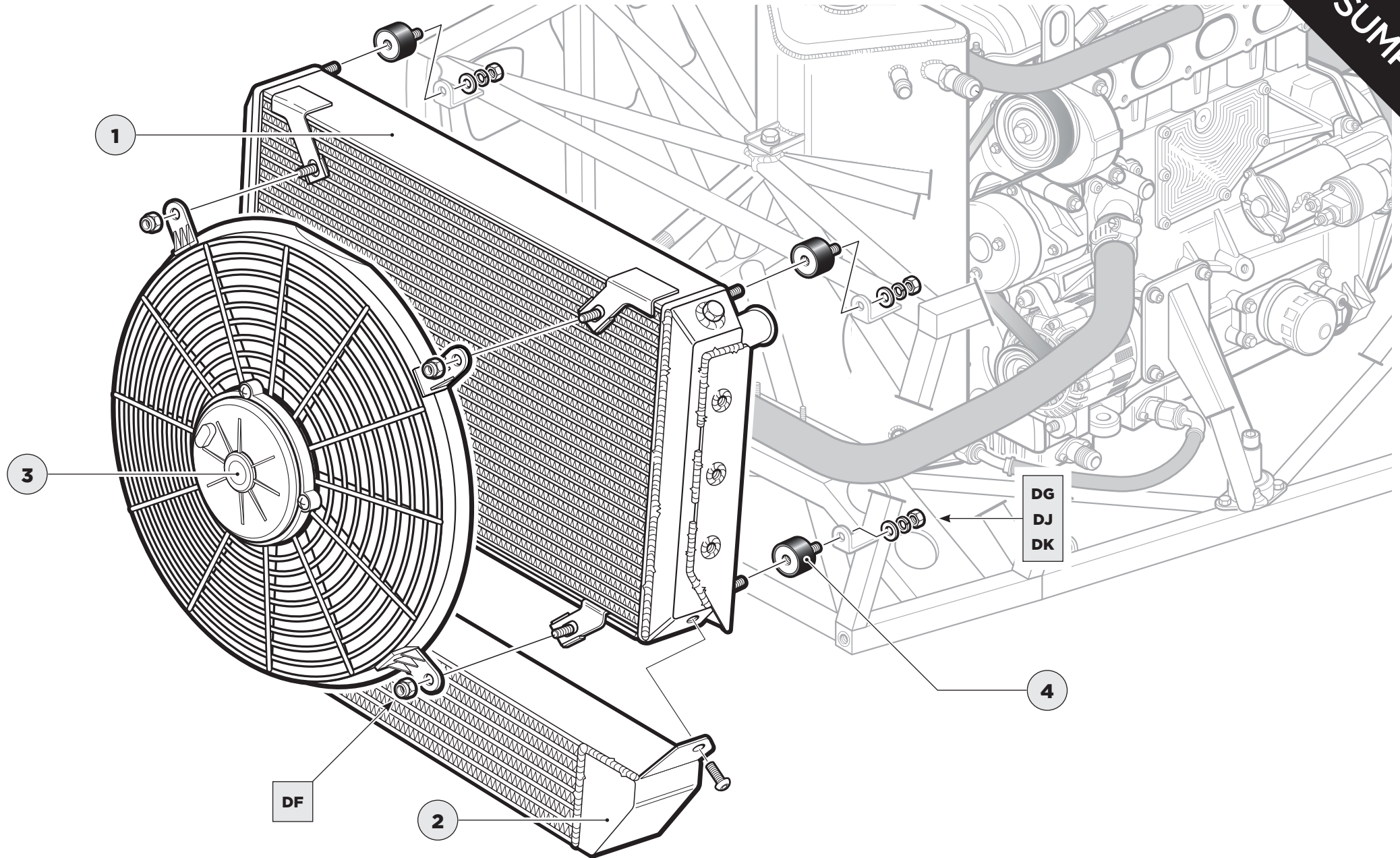

# THINGS ARE HEATING UP

## PARTS

- 1 Heater
- 2 Valve
- 3 Heater cable
- 4 Lower hose 110mm (cut from long length)
- 5 Upper hose 120mm (cut from long length)
- 6 Grommet

## TOOLS

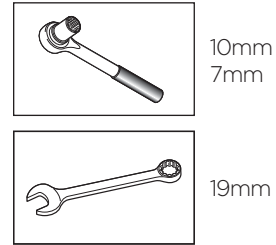

## FIXINGS

Pack D CATERHAM <span style="float: right;">44</span>					
COOLING SIGMA					
This pack may include extra fasteners to cover different options					
ITEM	BASIC DESCRIPTION	PART NUMBER	QTY	USED ON	ILLUSTRATION
1	EA Expansion tank bracket to chassis	888440	1	Expansion tank bracket to chassis	
2	EA Expansion tank to bracket	88714224	1	Expansion tank to bracket	
3	EA 3M radiator bracket	888420	4	3M radiator bracket	
4	EA Fan brackets to fan	88710224	4	Fan brackets to fan	
5	EA Fan to radiator coating - SI only	88968015	4	Fan to radiator coating - SI only	
6	EA 1/4 Fan to radiator and 3/4 radiator bracket	888775	8	1/4 Fan to radiator and 3/4 radiator bracket	
7	EA Radiator bobbin	888775	8	Radiator bobbin	
8	EA Expansion tank bracket	88710224	1	Expansion tank bracket	
9	EA 1/4 Fan to radiator and 3/4 radiator bracket	888775	13	1/4 Fan to radiator and 3/4 radiator bracket	
10	EA Radiator bobbin	888775	4	Radiator bobbin	
11	EA Radiator bobbin	888217025	4	Radiator bobbin	

Drawings are for illustrative purposes only and are not to scale. Page 1 of 2

x2

Pack D CATERHAM <span style="float: right;">44</span>					
COOLING SIGMA					
This pack may include extra fasteners to cover different options					
ITEM	BASIC DESCRIPTION	PART NUMBER	QTY	USED ON	ILLUSTRATION
12	EA Expansion tank bracket	888440	1	Expansion tank bracket	
13	EA Spring Washer	888440	8	8 x Radiator bobbin 1 x Expansion tank	
14	EA Hose Clip	8872040	6	2 x 1/4 Fan to radiator and 3/4 radiator bracket 2 x Radiator bobbin	
15	EA Hose Clip	8872030	2	1 x Engine outlet to top of Valve 1 x Engine outlet to heater cable	
16	EA Hose Clip	8871625	18	8 x Heater bracket 14 x Fan to radiator 1 x Expansion tank 4 x Dip Switch	
17	EA Hose Clip	8871625	6	Expansion tank small T piece	
18	EA Heat - Blank	88710224	12	Covering cap	

Drawings are for illustrative purposes only and are not to scale. Page 1 of 2

x4

## TIPS

Remember to remove bungs from heater.

Jamie A

Use 7mm for jubilee clips but not too tight!

Chris B

It's worth re-tightening the jubilee clips after a couple of uses of car.

John S



# WET / DRY SUMP REMOVE ENGINE PARTS

## PARTS

- 1 Engine mounts
- 2 Starter motor
- 3 Bellhousing

## TOOLS

## FIXINGS

## TIPS

*Remove the engine mounts, starter motor and bellhousing.*

**Mick F**

*Remember where the bolts go.*

**John S**

# WET / DRY SUMP REMOVE ENGINE PARTS

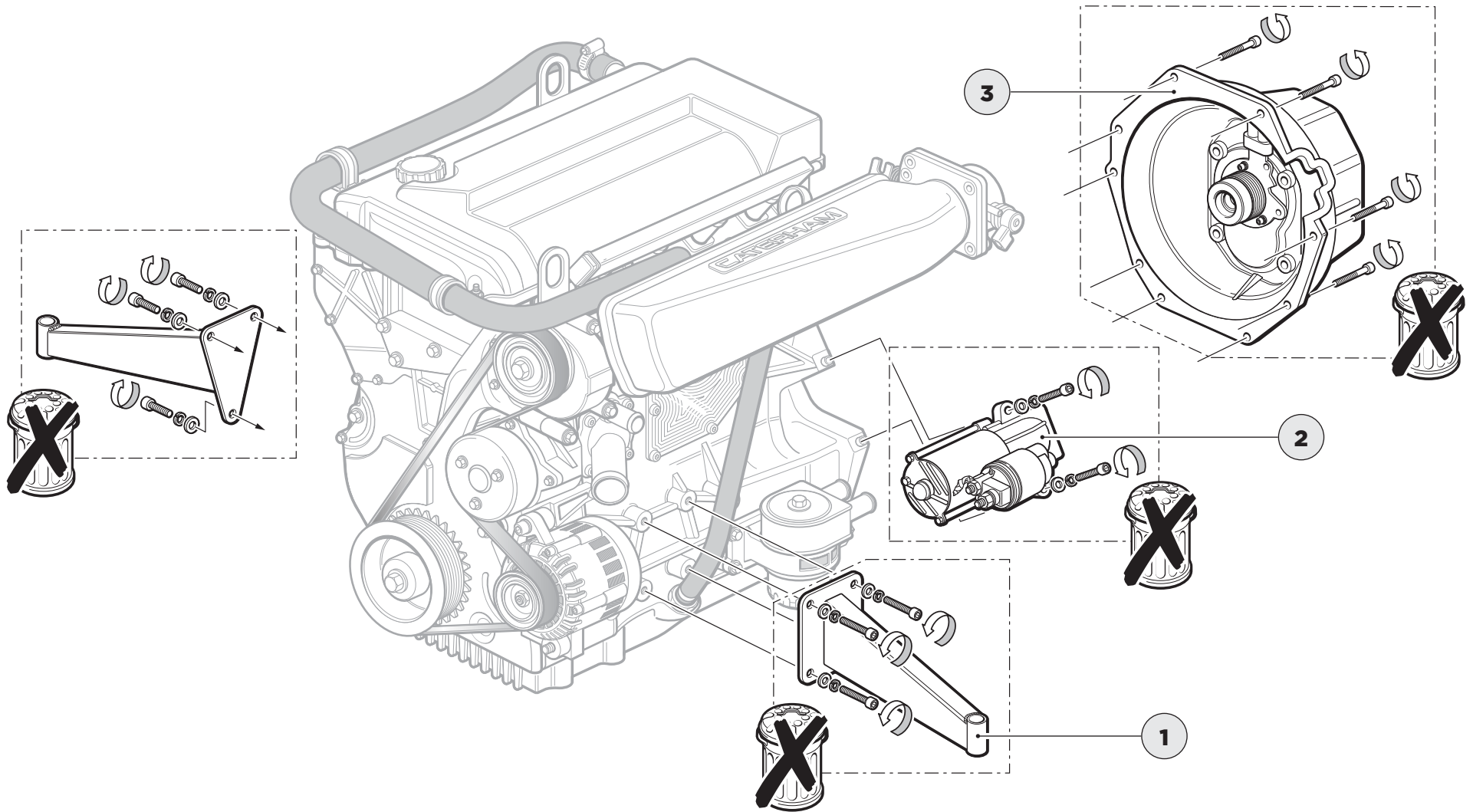

## WET / DRY SUMP REMOVE ENGINE PARTS

### PARTS

- 1 Alternator
- 2 Alternator Belt
- 3 Plenum

### TOOLS

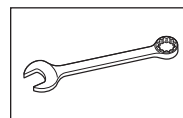

15mm

### FIXINGS

### TIPS

Remove alternator, alternator belt and plenum.

**Richard T**

Use a 15mm spanner and turn anti-clockwise to remove alternator.

**Harrison P**

Remember where the bolts go.

**John S**

# WET / DRY SUMP REMOVE ENGINE PARTS

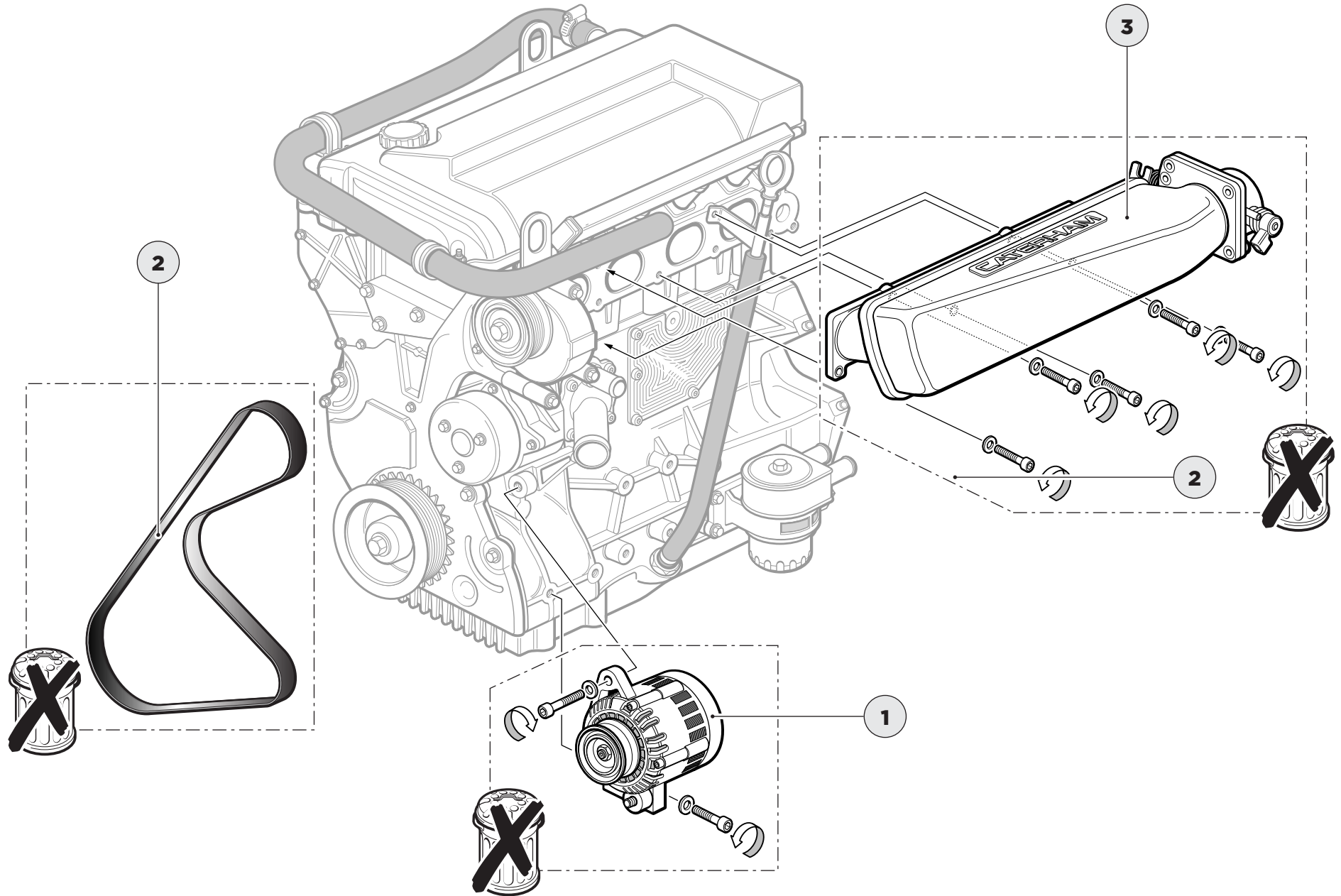

# WET / DRY SUMP ATTACH GEARBOX TO BELLHOUSING

## PARTS

- 1** Gearbox
- 2** Bellhousing

## TOOLS

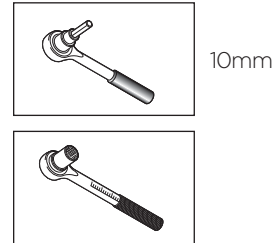

10mm

## FIXINGS

Pack <b>F</b>		<b>CATERHAM</b>		66	
		PACK NUMBER		3E22029B	
DURATEC GEARBOX 5 SPEED					
This pack may include extra fasteners to cover different options					
ITEM	BASIC DESCRIPTION	PART NUMBER	QTY	USED ON	ILLUSTRATION
1	FA Pin M10 x 20 x 3.5 Grade 12.9	302202A	2	AV Mount	
2	FB Caphead M12 x 40 x 1.75 Grade 12.9	3MCH12044	4	Bellhousing	
3	FC Caphead Bolt M10 x 20 Grade 12.9	3MCH10060	1	Bellhousing	
4	FD Caphead Bolt M10 x 20 Grade 12.9	3MCH10020	3	Bellhousing	
5	FE Caphead Bolt M10 x 4.4 Grade 12.9	3MCH10044	7	x 5 Bellhousing x 2 Gearbox Motor	
6	FF Caphead Bolt M8 x 20 Grade 12.9	302207A	4	AV Mount	
7	FG Caphead Bolt M8 x 20 Grade 12.9	3MCH30020	3	Clutch Release Bearing	
8	FH Substandard Bolt M8 x 10 Grade 10.9 HexHead Pro	3021100A	1	Gear Lever	
9	FI Nylon Nut M8	3M3708	4	AV Mount	
10	FJ Plain Washer M10	3M3014	2	AV Mount	
11	FK Plain Washer M12	302203A	4	Bellhousing	

x4

x4

Pack <b>F</b>		<b>CATERHAM</b>		66	
		PACK NUMBER		3E22029B	
DURATEC GEARBOX 5 SPEED					
This pack may include extra fasteners to cover different options					
ITEM	BASIC DESCRIPTION	PART NUMBER	QTY	USED ON	ILLUSTRATION
12	FL Plain Washer M8	3M3008	3	Gear Lever	
13	FM Spring Washer M10	302202A	2	AV Mount	
14	FN Spring Washer M12	W5HM12	4	Gearbox	
15	FO Spring Washer M10	W5HM10	4	x 2 Starter Motor x 2 Front Bellhousing	
16	FP Spring Washer M8	W3HM8	3	Clutch Slave Cylinder	

x4

## TIPS

# WET / DRY SUMP ATTACH GEARBOX TO BELLHOUSING

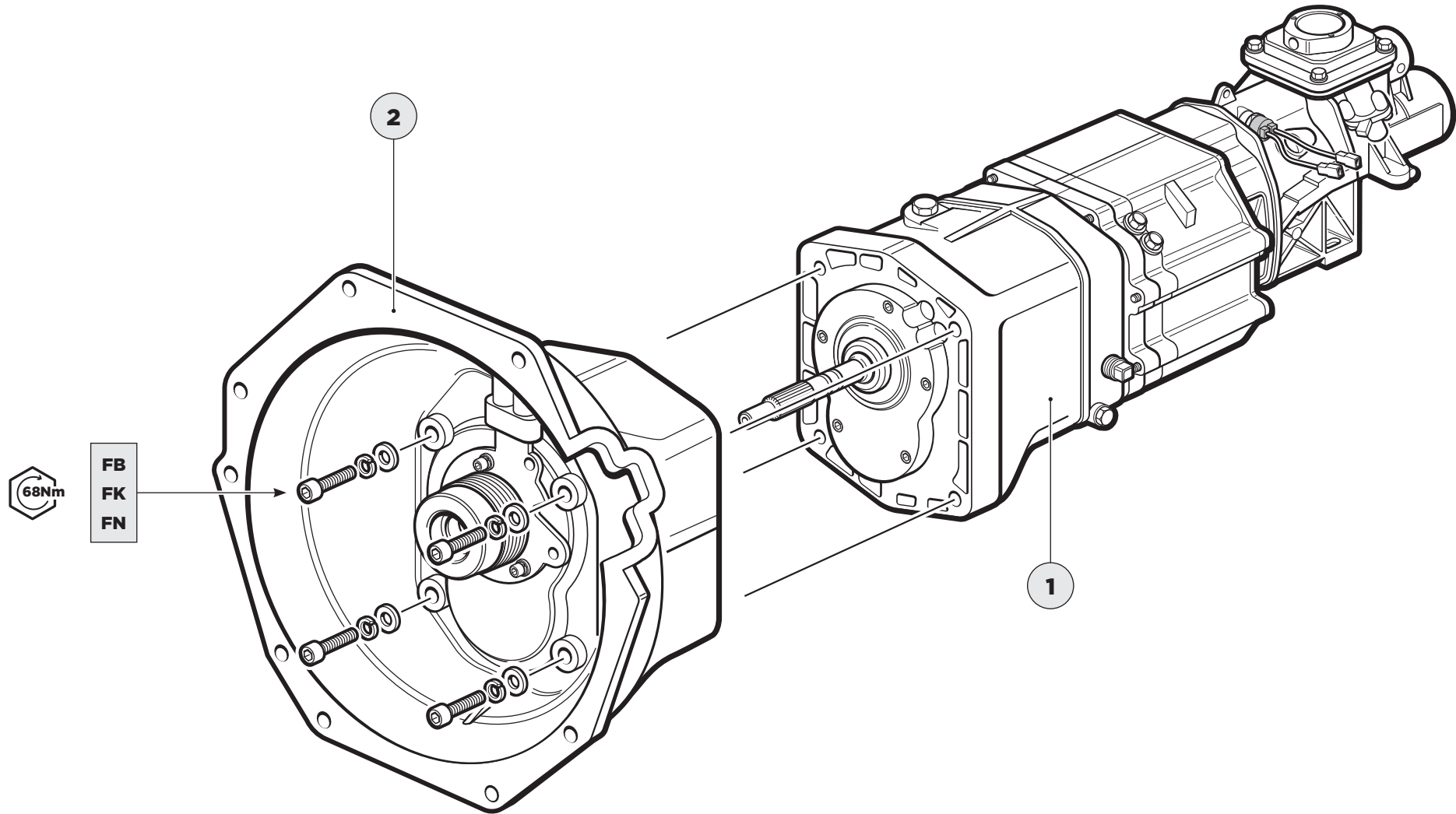

## WET / DRY SUMP AND THEN GEARBOX TO ENGINE

### TOOLS

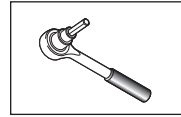

8mm



### FIXINGS

### TIPS

*Refit bellhousing and gearbox to engine.*

Harrison P

# WET / DRY SUMP AND THEN GEARBOX TO ENGINE

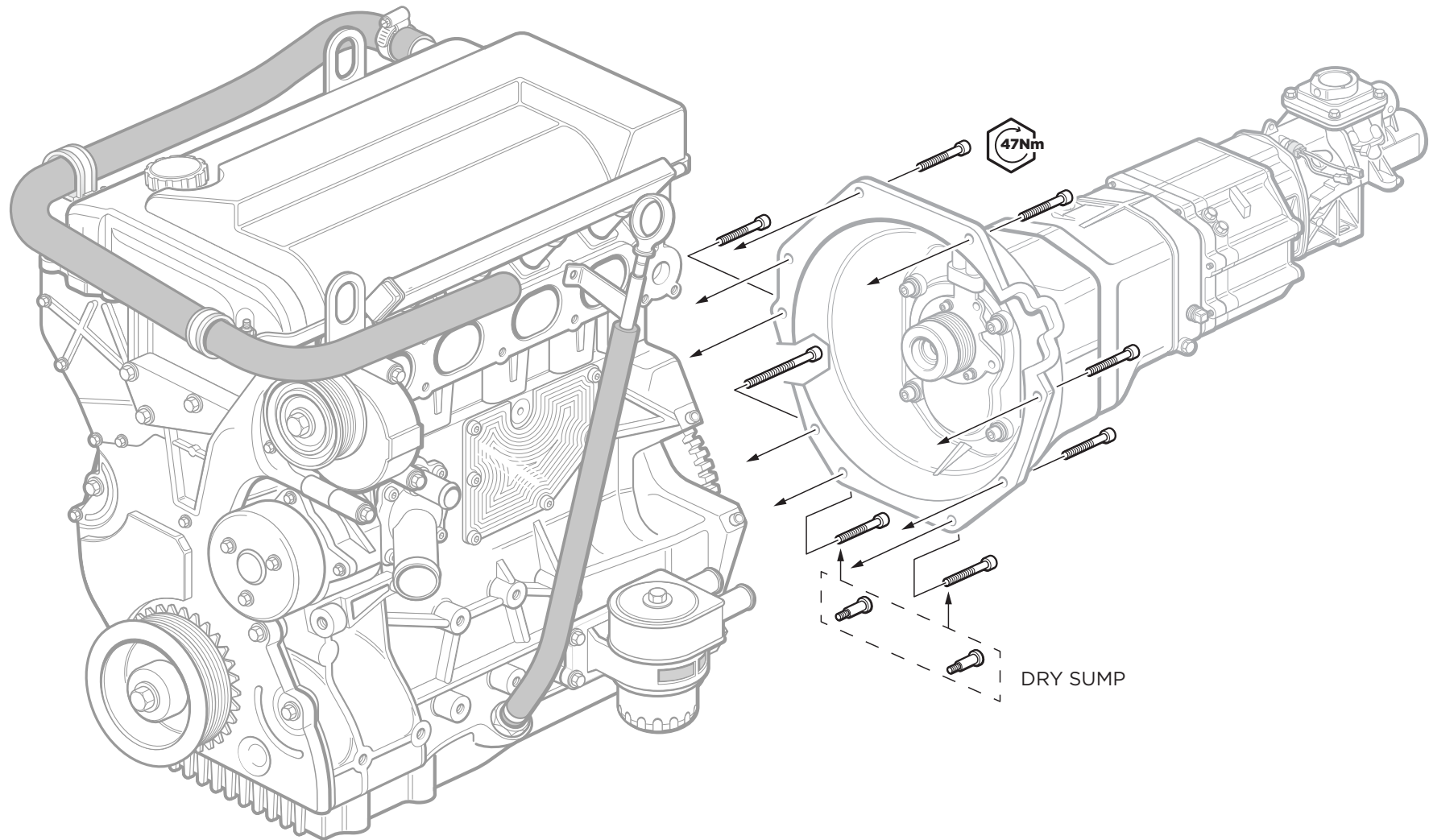

## FILLING THE ENGINE AND GEARBOX WITH OIL

---

### PARTS

Engine oil SW-30

Gear oil GL4

### TOOLS

### FIXINGS

### TIPS



**Ford 2.0L Engine**

Wet Sump = 5.0 Litres

Dry Sump = 7.0 Litres (3.5 Litres in Engine,  
3.5 Litres in Tank, top up if required)

5 Speed Gearbox = (Pre-Filled)

Before Installation. You can double check the oil level by removing the plug on the side. The oil should be to this level.

# WET / DRY SUMP AT LAST THE ENGINE IS GOING IN

## PARTS

- 1 Engine mounts
- 2 Engine rubbers

## TOOLS

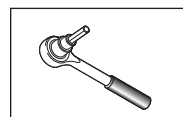

6mm  
8mm  
3/8



13mm

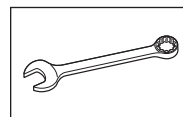

13mm  
15mm

## FIXINGS

## TIPS

When fitting engine rubbers and mounts, fit as loosely as possible so you can wiggle things to get bolts in.

James A

Tighten gradually once all bolts are in.

Chris N

Protect the chassis with soft stuff such as cardboard or a folded towels / blankets.

Harry P

# WET / DRY SUMP AT LAST THE ENGINE IS GOING IN

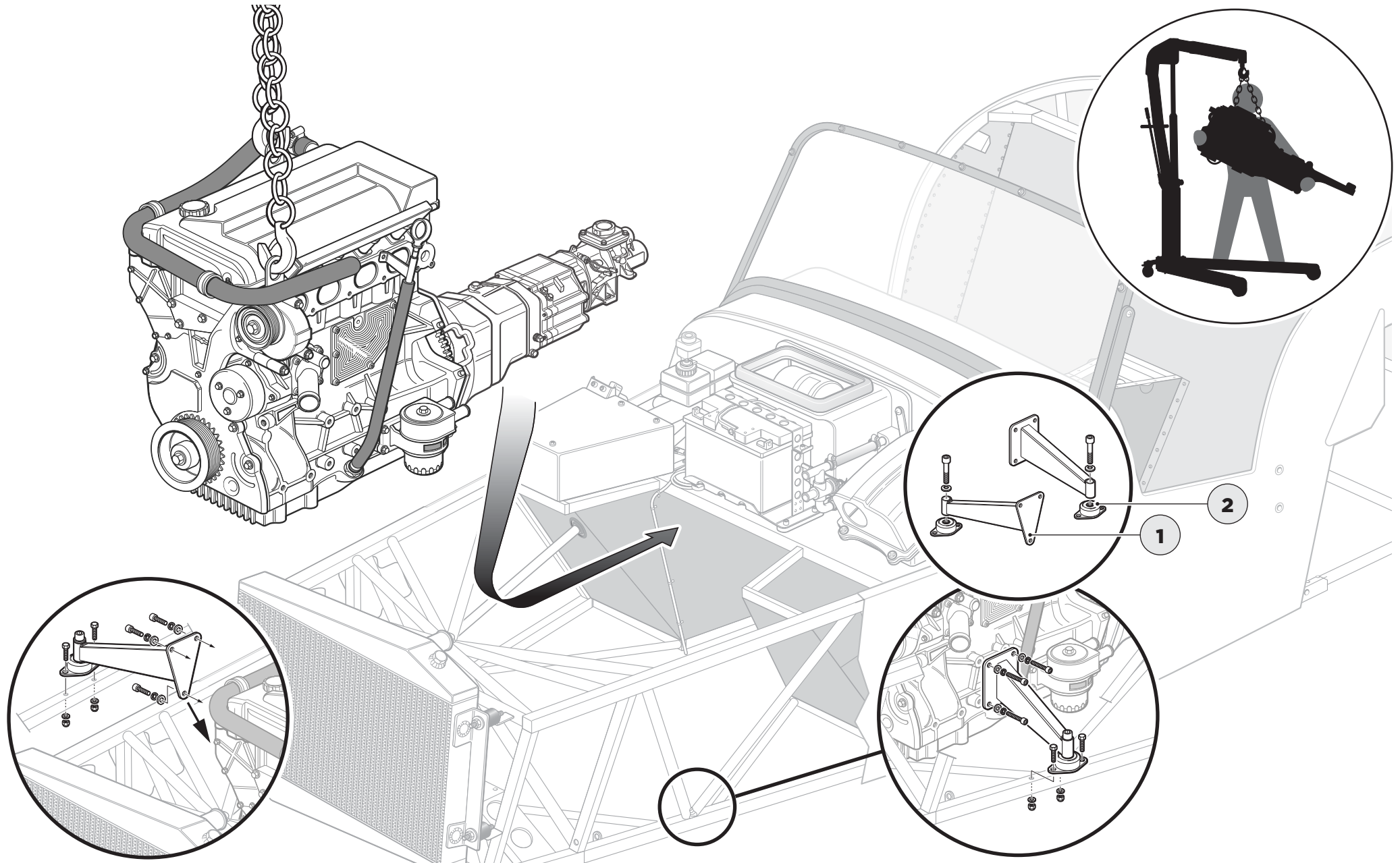

## WET / DRY SUMP AND THE GEARBOX IS FIXED IN PLACE

### PARTS

### TOOLS

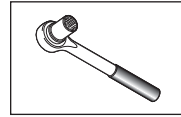

13mm  
22mm

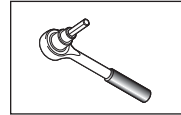

6mm

### FIXINGS

### TIPS

Once the engine is in, the wiring can be connected to the car's loom. It should be self explanatory.

**Chris B**

See IVA guide – how to secure a loom.

**Grant P**

## WET / DRY SUMP AND THE GEARBOX IS FIXED IN PLACE

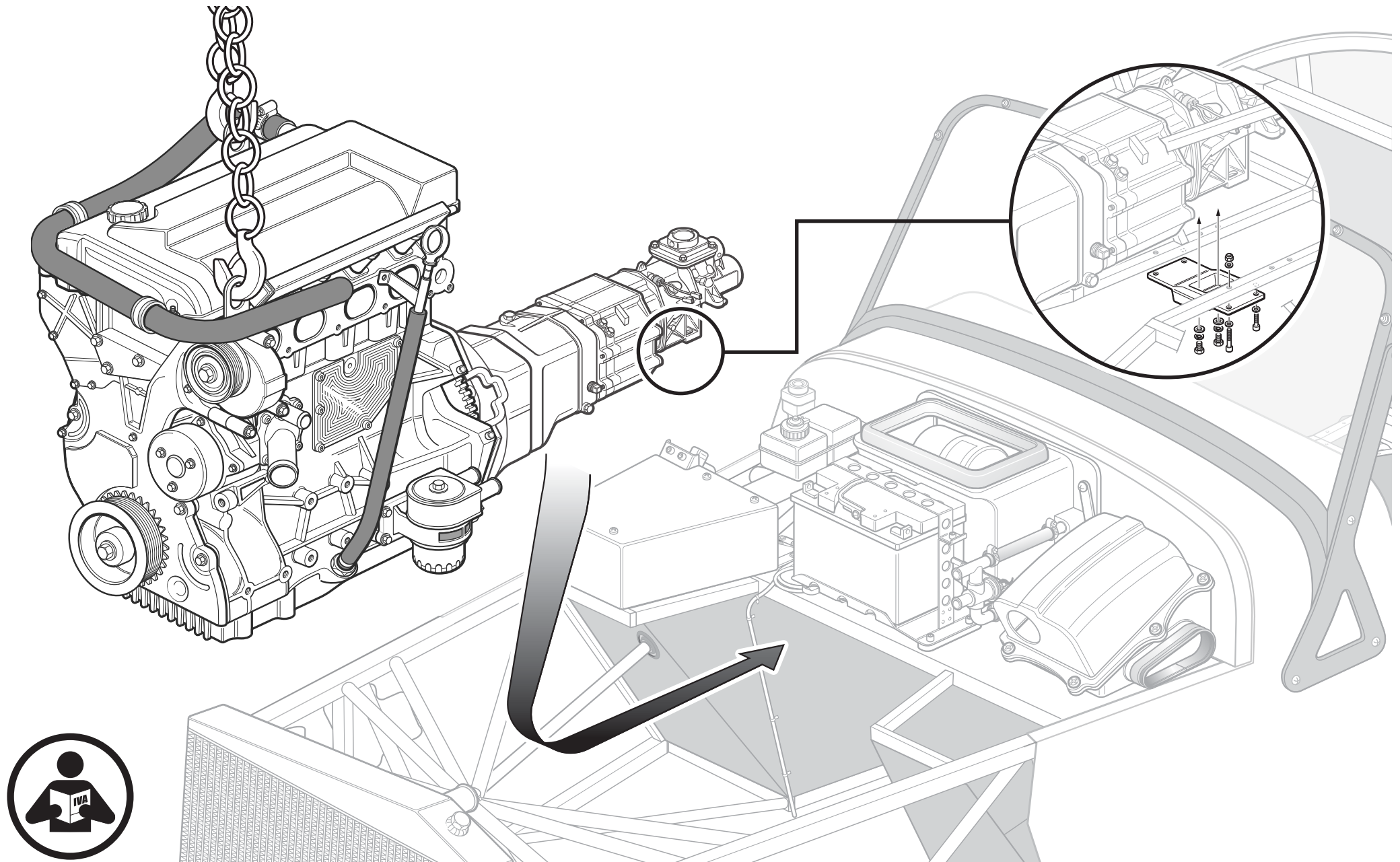

# WET / DRY SUMP REFIT ALTERNATOR, BELT & STARTER MOTOR

## PARTS

- 1 Alternator belt
- 2 Alternator
- 3 Starter motor

## TOOLS

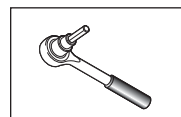

8mm

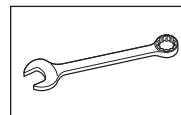

15mm

## FIXINGS

## TIPS

Refit alternator, alternator belt and starter motor.

Lee A

# WET / DRY SUMP REFIT ALTERNATOR, BELT & STARTER MOTOR

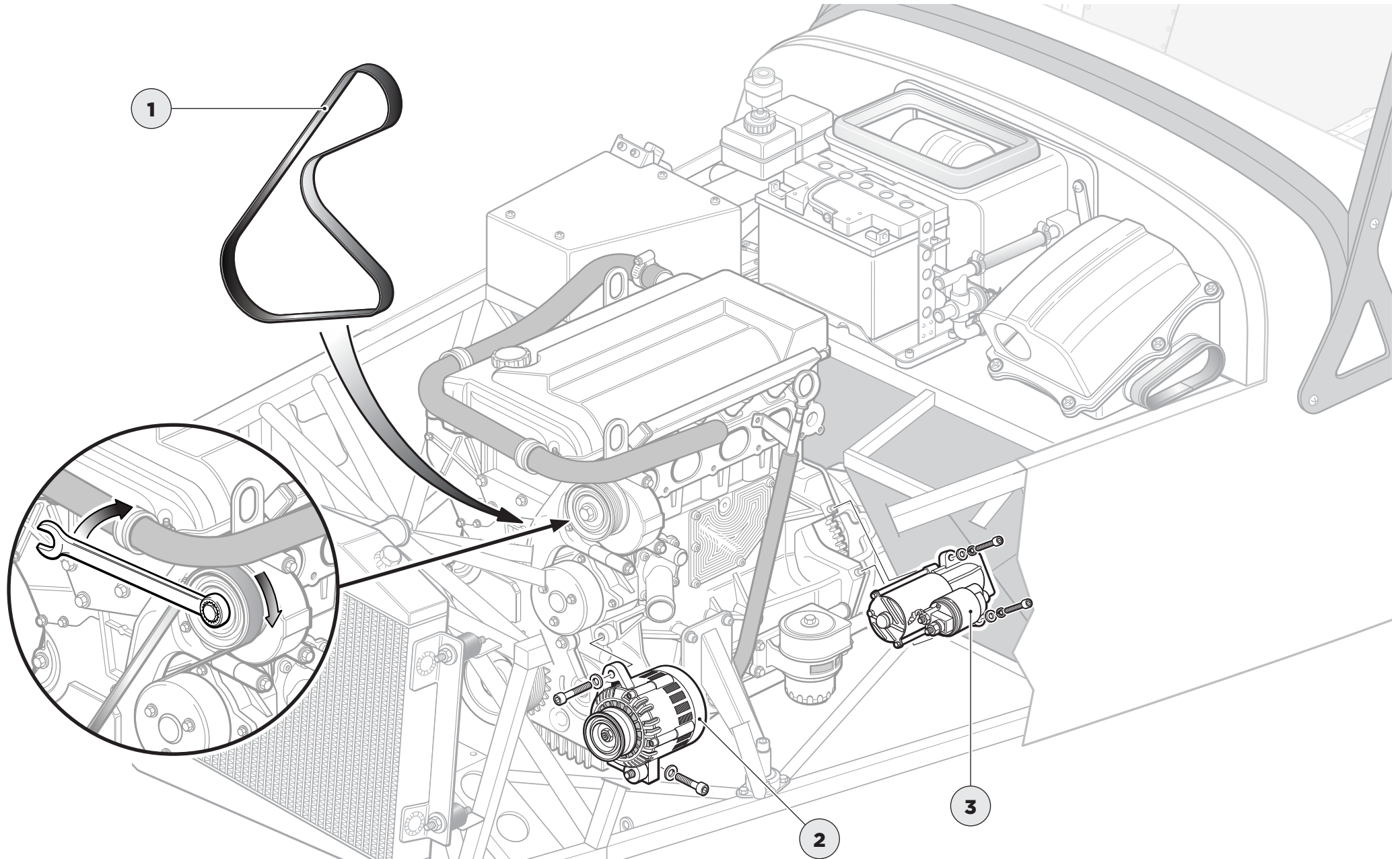

# WET SUMP LOWER RADIATOR HOSE

## PARTS

- 1 Lower radiator hose

## TOOLS

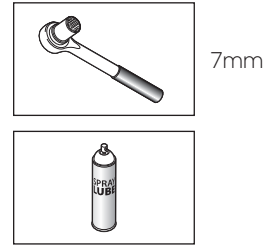

## FIXINGS

Pack D		CATERHAM		44	
		PACK NUMBER		SICCATB	
COOLING SIGMA					
This pack may include extra fasteners to cover different options					
ITEM	BASIC DESCRIPTION	PART NUMBER	QTY	USED ON	ILLUSTRATION
1	EA	Roll Mat 2.25 (Roll Mat)	1	Expansion tank bracket to chassis	
2	DB	Roll Mat 2.25 (Roll Mat)	1	Expansion tank to bracket	
3	DC	Roll Mat 2.25 (Roll Mat)	4	SM radiator bracket	
4	DD	Roll Mat 2.25 (Roll Mat)	4	Fan brackets to fan	
5	DE	Roll Mat 2.25 (Roll Mat)	4	Fan to radiator mounting - 20 (10)	
6	DF	Roll Mat 2.25 (Roll Mat)	8	40 Fan to radiator and CV radiator bracket	
7	DG	Roll Mat 2.25 (Roll Mat)	8	Radiator bobbin	
8	DH	Roll Mat 2.25 (Roll Mat)	1	Expansion tank bracket	
9	DI	Roll Mat 2.25 (Roll Mat)	13	18 x 50 Fan bracket 40 Fan to radiator and CV radiator bracket	
10	DJ	Roll Mat 2.25 (Roll Mat)	4	Radiator bobbin back	
11	DK	Roll Mat 2.25 (Roll Mat)	4	Radiator bobbin front	

Drawings are for illustrative purposes only and are not to scale. Page 1 of 2

Pack D		CATERHAM		44	
		PACK NUMBER		SICCATB	
COOLING SIGMA					
This pack may include extra fasteners to cover different options					
ITEM	BASIC DESCRIPTION	PART NUMBER	QTY	USED ON	ILLUSTRATION
12	EL	Roll Mat 2.25 (Roll Mat)	1	Expansion tank bracket	
13	EM	Roll Mat 2.25 (Roll Mat)	8	8 x Radiator bobbin 1 x Expansion tank	
14	DN	Hose Clip 20 (10)	6	2 x 1/2 shape hose to water rail 2 x 2 Fan radiator hose 2 x 2 Bottom radiator hose	
15	DO	Hose Clip 20 (10)	2	1 x Engine outlet to top 1 Engine 1 x Engine outlet to bottom (10)	
16	DP	Hose Clip 20 (10)	18	8 x Radiator bobbin 1 x Expansion tank 2 x Fan 1 x CV (10)	
17	DD	Hose Clip 20 (10)	6	Expansion tank small T piece	
18	DR	Roll - Black (20 x 10)	12	Coupling cap	

Drawings are for illustrative purposes only and are not to scale. Page 1 of 2

x2

## TIPS

Reminder for later on – nip up once the car has been run.  
**Mick F**

Support hose by cable tying to chassis rails. Make sure they are clear of the steering rack.  
**Grant P**

Fit the hose to the larger outlet on the engine.  
**Dan D**

# WET SUMP LOWER RADIATOR HOSE

WET SUMP

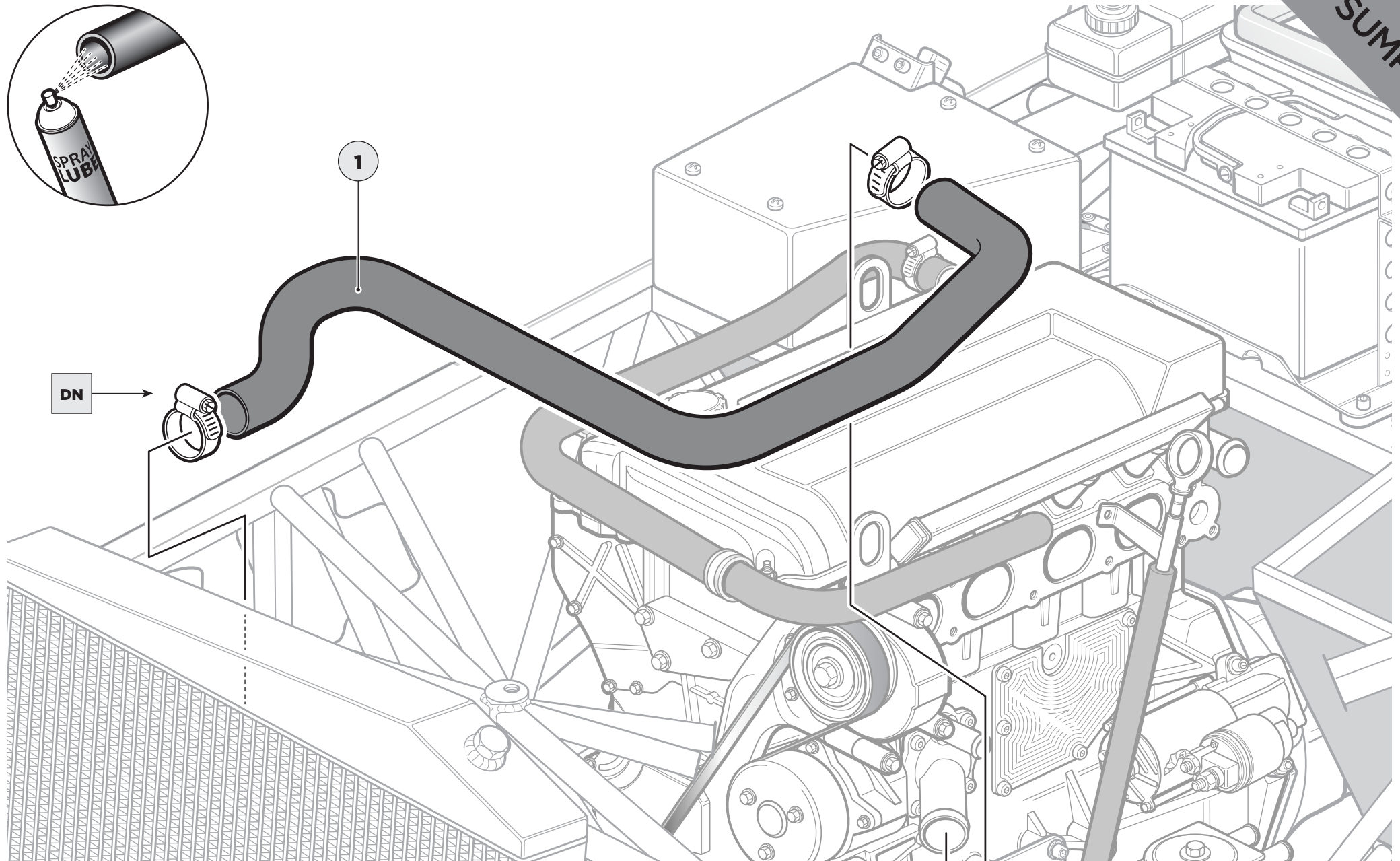

# WET SUMP UPPER RADIATOR HOSE

## PARTS

- 1 Upper radiator hose

## TOOLS

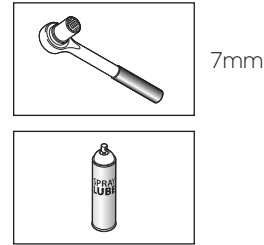

## FIXINGS

Pack D		CATERHAM		44	
		PACK NUMBER		3002478	
COOLING SIGMA					
This pack may include extra fasteners to cover different options					
ITEM	BASIC DESCRIPTION	PART NUMBER	QTY	USED ON	ILLUSTRATION
1	DN Rail Kit 2.00 Rear 2.0	888440	1	Expansion tank bracket to chassis	
2	DB Radiator 1.50 X 3.00	88714424	1	Expansion tank to bracket	
3	DC Radiator 887020 Rear 2.0	888420	4	SM radiator bracket	
4	DD Rail Kit 2.18 with Square bracket	88710724	4	Fan brackets to fan	
5	DE Radiator 887010 Front 2.0	88841010	4	Fan to radiator mounting - 20 100g	
6	DF 16mm Nut M8	888776	8	1/4 Fan to radiator and DV radiator bracket	
7	DG Plain Nut M8	888776	8	Radiator bobbin	
8	DH 16mm Nut 1.47	88710714	1	Expansion tank bracket	
9	DI Plain Washer 16 Hex 2.0	88841014	13	1/4 x DV Fan bracket 1/4 Fan Brackets 1/4 Expansion tank bracket	
10	DJ Plain Washer 16 Hex 2.0	88841014	4	Radiator bobbin back	
11	DK Plain Washer 16 Hex 2.0	88841014	4	Radiator bobbin front	

Drawings are for illustrative purposes only and are not to scale. Page 1 of 2

Pack D		CATERHAM		44	
		PACK NUMBER		3002478	
COOLING SIGMA					
This pack may include extra fasteners to cover different options					
ITEM	BASIC DESCRIPTION	PART NUMBER	QTY	USED ON	ILLUSTRATION
12	DL Plain Washer 16 Hex 2.0	88841014	1	Expansion tank bracket	
13	DM Spring Washer 16 Hex 2.0	88841012	8	8 x Radiator bobbin 1 x Expansion tank	
14	DN Hose Clip 20 40mm	50725-40	6	2 x 1/4 shape hose to water rail 2 x Top radiator hose 2 x Bottom radiator hose	
15	DD Hose Clip 20 20mm	50723-20	2	1 x Engine outlet to top 1.5mm 1 x Engine outlet to bottom 1.5mm	
16	DP Hose Clip 17 20mm	50719-20	18	6 Radiator bobbin 6 Expansion tank 6 DV Fan 6 DV Fan	
17	DD Hose Clip 16 16mm	50719-16	6	Expansion tank small 1/4 piece	
18	DR Hex - Black 1.25 x 1.50	1076-01015	12	Cowling cap	

Drawings are for illustrative purposes only and are not to scale. Page 1 of 2

x2

## TIPS

Reminder for later on – nip up once the car has been run.  
Mick F

# WET SUMP UPPER RADIATOR HOSE

WET SUMP

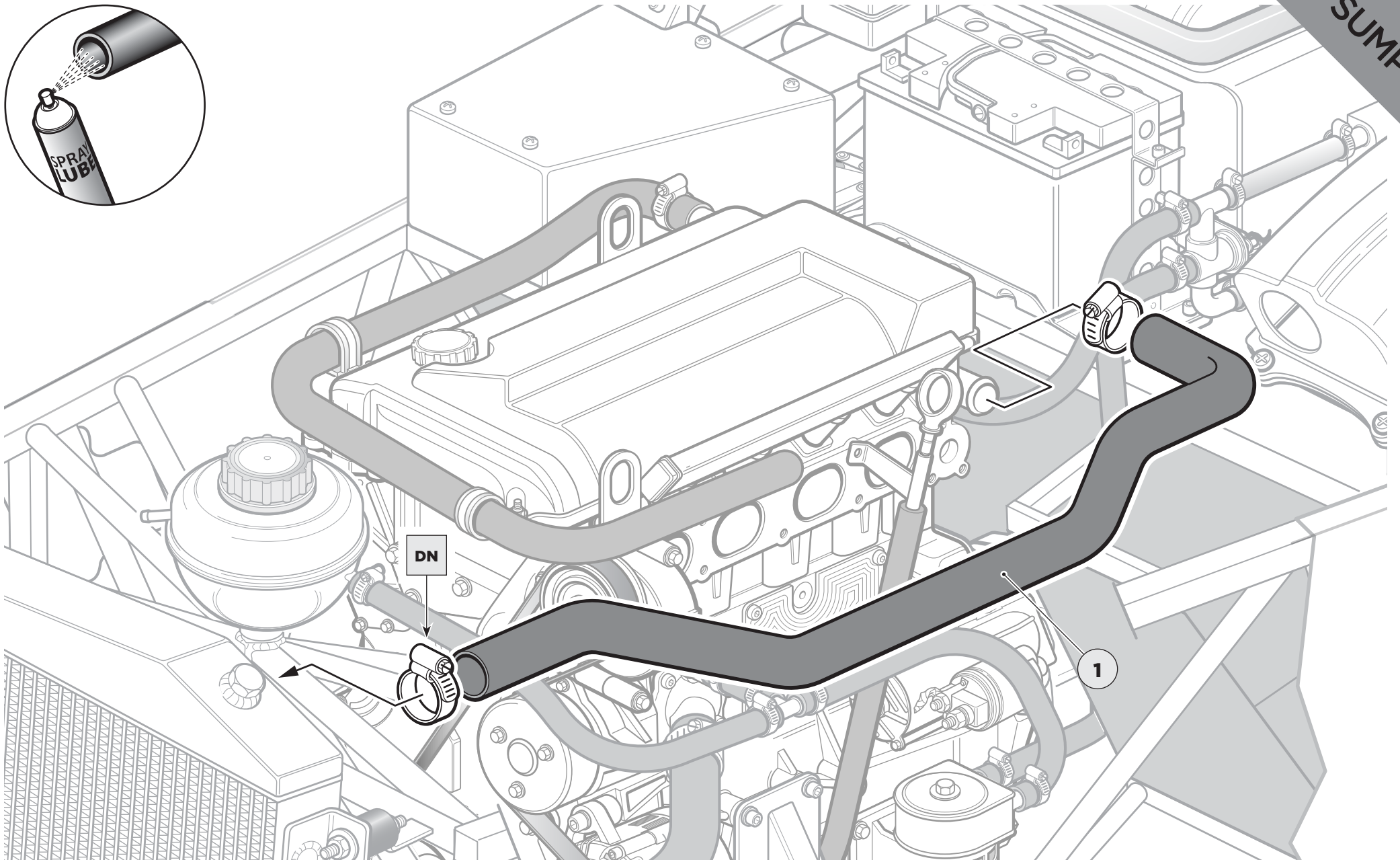

# WET SUMP EXPANSION BOTTLE

## PARTS

- 1 Expansion bottle
- 2 Expansion bottle cap
- 3 Expansion bottle bracket

## TOOLS

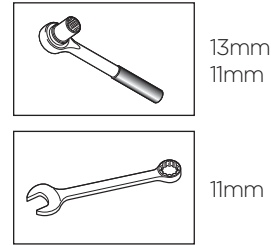

## FIXINGS

Pack D		CATERHAM		44	
		PACK NUMBER		3002478	
COOLING SIGMA					
This pack may include extra fasteners to cover different options					
ITEM	BASIC DESCRIPTION	PART NUMBER	QTY	USED ON	ILLUSTRATION
1	DA Bolt M6 x 20 Coarse thread	BMB030	1	Expansion tank bracket to chassis	
2	DB Selfwax 1/4" x 3/4"	SF14234	1	Expansion tank to bracket	
3	DC Selfwax M8x20 Heavy duty	BMB220	4	5M radiator bracket	
4	DD Bolt M6 x 16 with square neck	SD12024	4	Fan brackets to fan	
5	DE Selfwax M8x20 Fanwing	SFB0210	4	Fan to radiator mounting - SD 1000	
6	DF Hex Nut M8	M8079	8	4x Fan to radiator 4x 5M radiator bracket	
7	DG Plain Nut M8	M8079	8	Radiator bobbin	
8	DH Nylon Nut 1/4"	NPY114	1	Expansion tank bracket	
9	DI Plain Washer 1/4" Heavy duty	WPY114	13	8 x SIV rad bracket 4 x Fan bearings 1 x Expansion tank bracket	
10	DJ Plain Washer 1/4" Heavy duty	WPY070	4	Radiator bobbin back	
11	DK Plain Washer 1/4" Heavy duty	SFB0210	4	Radiator bobbin back	

Drawings are for illustrative purposes only and are not to scale. Page 1 of 2

x1

x1

x1

x1

Pack D		CATERHAM		44	
		PACK NUMBER		3002478	
COOLING SIGMA					
This pack may include extra fasteners to cover different options					
ITEM	BASIC DESCRIPTION	PART NUMBER	QTY	USED ON	ILLUSTRATION
12	DL Plain Washer 1/4" x 3/4" Heavy duty	WPH14234	1	Expansion tank bracket	
13	DM Spring Washer 5/16" Heavy duty	WSP5117	9	8 x Radiator bobbin 1 x Expansion tank	
14	DN Hex Cap 1/4" 20mm	SC170140	6	2 x 5M radiator bracket 2 x 5M radiator back 2 x Radiator bobbin back	
15	DO Hex Cap 1/4" 20mm	SC170130	2	1 x Engine outlet to top 1 frame 1 x Engine outlet to motor 1000	
16	DP Hex Cap 1/4" 20mm	SC170120	18	6 x Fan bearings 2 x Expansion tank 2 x Fan wing 6 x 5M Spring	
17	DD Hex Cap 1/4" 20mm	SC170130	6	Expansion tank small 1 piece	
18	DR Plain Wash 1/4" x 3/4" Heavy duty	WPH14234	12	Cooling fan	

Drawings are for illustrative purposes only and are not to scale. Page 1 of 2

x1

x1

## TIPS

Throw away the red cap that came on the expansion bottle.

Lloyd D

# WET SUMP EXPANSION BOTTLE

WET SUMP

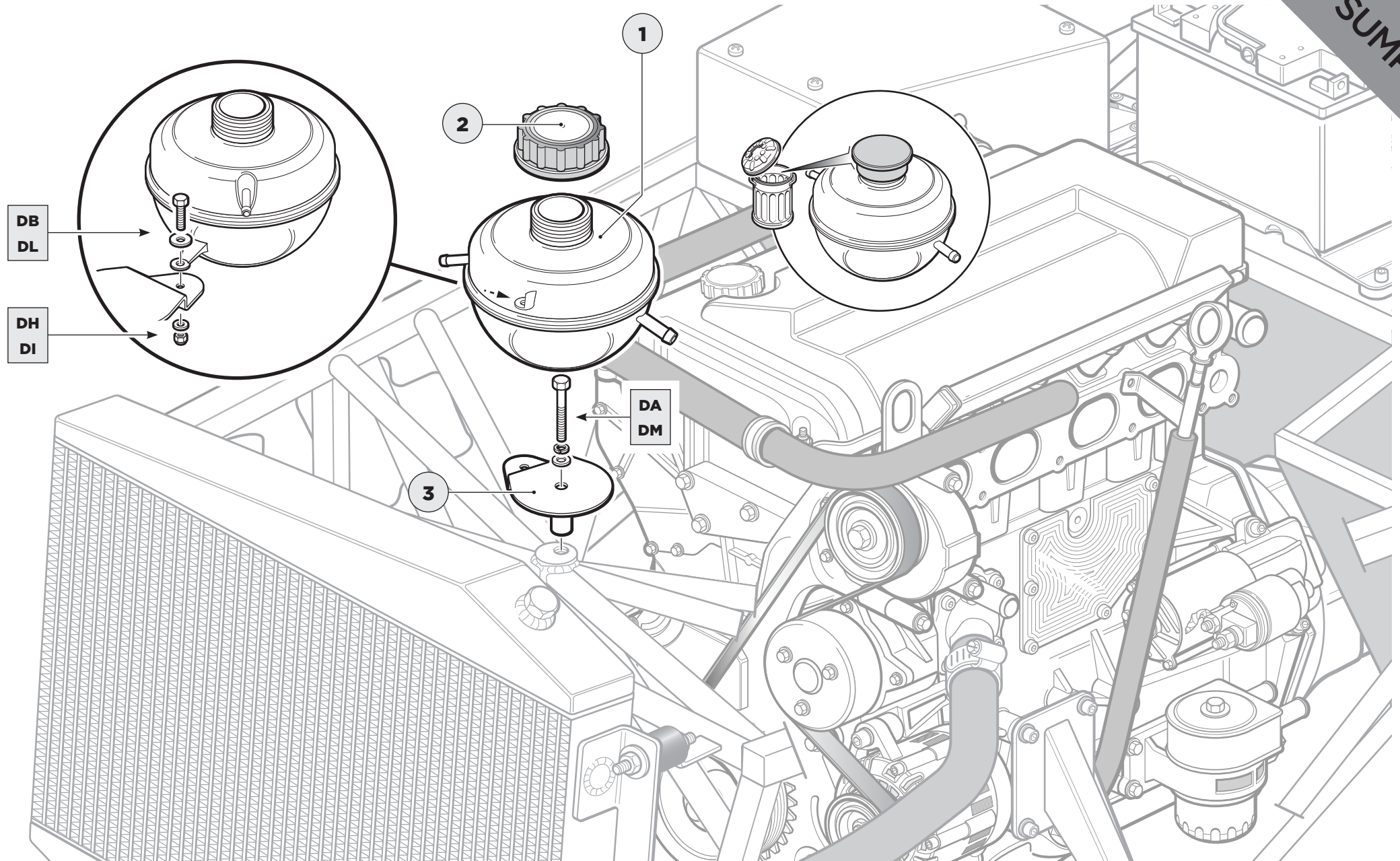

# WET SUMP HOSES

## PARTS

- 1** T-piece
- 2** Hose roll
- 3** Reducer hose

## TOOLS

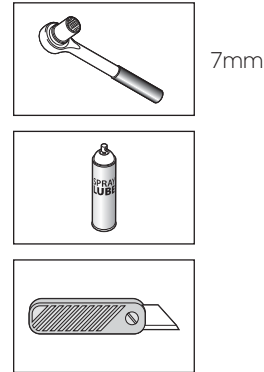

## FIXINGS

Pack <b>D</b>		<b>CATERHAM</b>		44	
		PACK NUMBER		SICCATB	
COOLING SIGMA					
This pack may include extra fasteners to cover different options					
ITEM	BASIC DESCRIPTION	PART NUMBER	QTY	USED ON	ILLUSTRATION
1	Ball Nut 2.25 Hex 2.5	888440	1	Expansion tank bracket to chassis	
2	Ball Nut 1.50 Hex 3.00	88714224	1	Expansion tank to bracket	
3	Ball Nut 1.50 Hex 3.00	888420	4	SM radiator bracket	
4	Ball Nut 2.00 Hex 3.00	88710224	4	Fan brackets to fan	
5	Ball Nut 1.50 Hex 3.00	8884210	4	Fan to radiator	
6	Ball Nut 1.50 Hex 3.00	8884210	8	4 x Fan to radiator	
7	Ball Nut 1.50 Hex 3.00	8884210	8	Radiator bobbin	
8	Ball Nut 1.50 Hex 3.00	88710224	1	Expansion tank bracket	
9	Ball Nut 1.50 Hex 3.00	8884210	13	13 x 10V fan brackets 1 x Expansion tank bracket	
10	Ball Nut 1.50 Hex 3.00	8884210	4	Radiator bobbin back	
11	Ball Nut 1.50 Hex 3.00	8884210	4	Radiator bobbin front	

Drawings are for illustrative purposes only and are not to scale. Page 1 of 2

Pack <b>D</b>		<b>CATERHAM</b>		44	
		PACK NUMBER		SICCATB	
COOLING SIGMA					
This pack may include extra fasteners to cover different options					
ITEM	BASIC DESCRIPTION	PART NUMBER	QTY	USED ON	ILLUSTRATION
12	Ball Nut 1.50 Hex 3.00	8884210	1	Expansion tank bracket	
13	Spring Washer Hex 3.00	8884210	8	8 x Radiator bobbin 1 x Expansion tank	
14	Hose Clip 22 - 26mm	80723-40	6	2 x 1 x Engine outlet to expansion tank 2 x 1 x Expansion tank to expansion tank	
15	Hose Clip 22 - 26mm	80723-30	2	1 x Engine outlet to expansion tank 1 x Engine outlet to expansion tank	
16	Hose Clip 17 - 22mm	80716-25	18	8 x Radiator bobbin 1 x Expansion tank 1 x Dip Sump 1 x Radiator	
17	Hose Clip 17 - 22mm	80716-16	6	Expansion tank small T-piece	
18	Ball Nut Hex 3.00	88710224	12	Crossing flap	

Drawings are for illustrative purposes only and are not to scale. Page 1 of 2

x1  
x7

## TIPS

You will need to cut hoses to size.

John S

The hose that comes from the engine reduces in diameter to the T-piece.

Chris N

# WET SUMP HOSES

WET SUMP

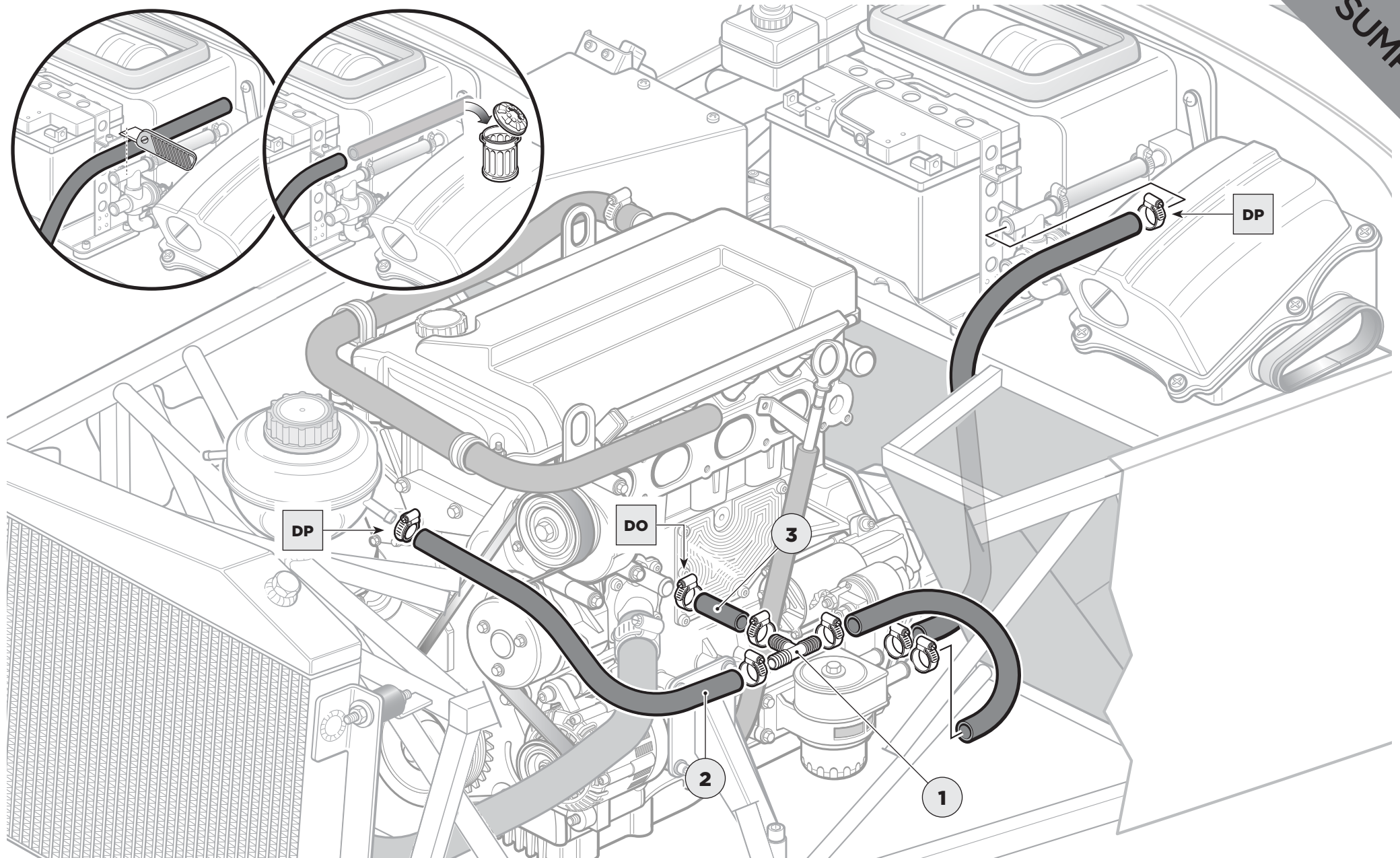

# DRY SUMP FIXING THE TANK

## PARTS

- 1 Dry sump tank
- 2 Temperature sender
- 3 P-clips

## TOOLS

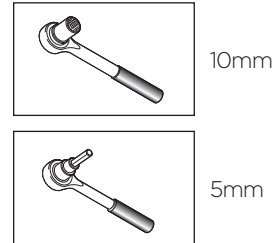

## FIXINGS

### Unmarked bag:

- M8 x 20 caphead
- M8 spring and plain head washer
- M6 x 20 bolts (x2)
- M6 Nyloc (x2)
- 1/4" washers (x2)

## TIPS

The M8 caphead fits the tab on the tank to the chassis.

**John K**

The bottom P-clips fix on to the lower chassis rails.

**Grant P**

The tab on the tank may need to be spaced out. Use M8 washers.

**Jamie A**

Put PTFE tape in the temperature sensor.

**Chris N**

# DRY SUMP FIXING THE TANK

DRY SUMP

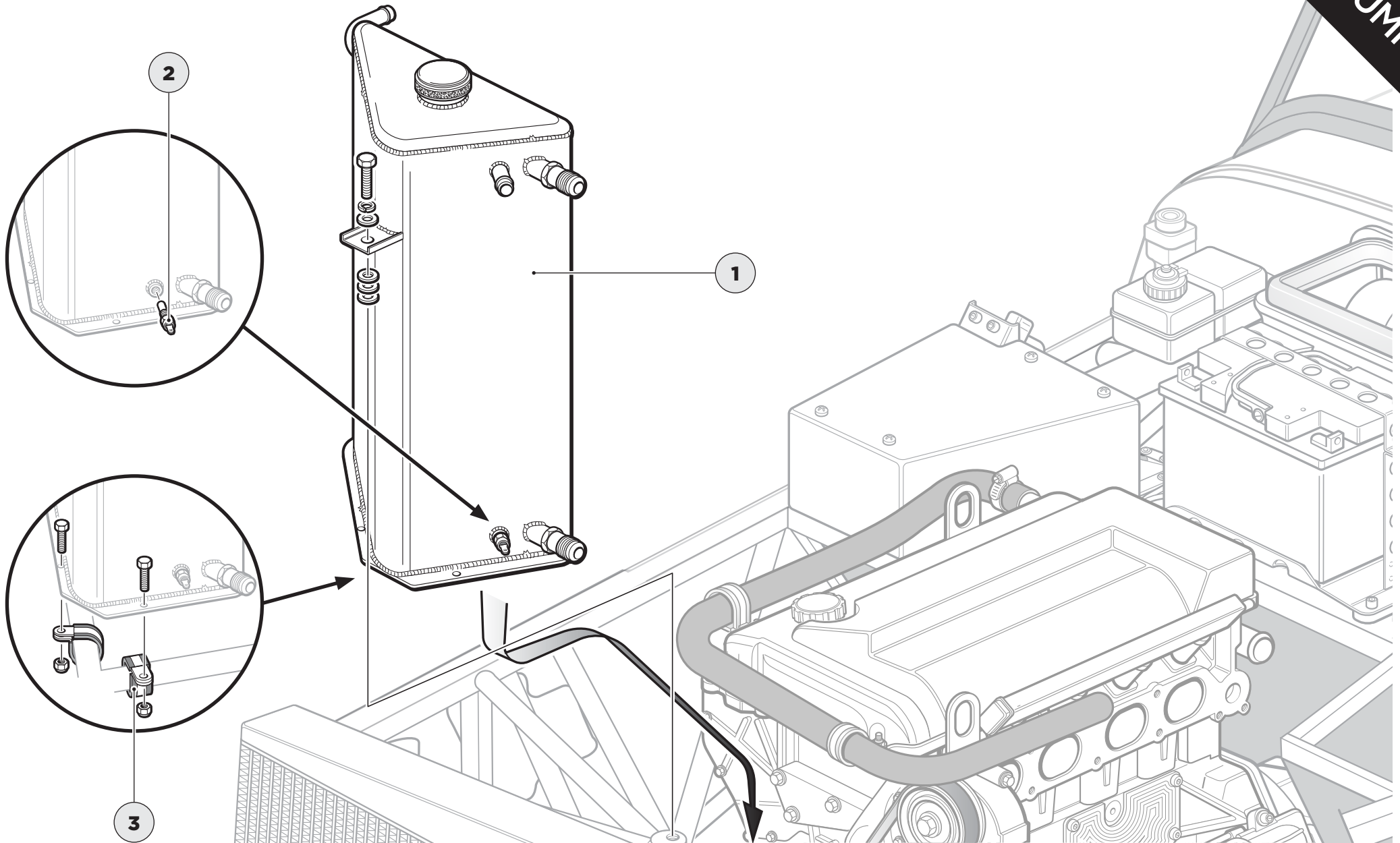

# DRY SUMP FITTING THE EXPANSION BOTTLE

## PARTS

- 1 Expansion bottle
- 2 Expansion bottle cap
- 3 Expansion bottle bracket
- 4 Expansion bottle plate

## TOOLS

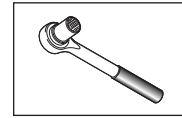

13mm  
11mm

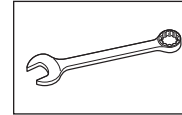

11mm

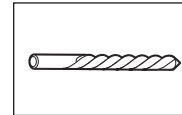

5/32

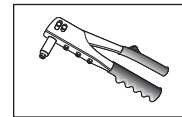

## FIXINGS

Pack D		CATERHAM		44	
		PACK NUMBER		SICCATB	
COOLING SIGMA					
This pack may include extra fasteners to cover different options					
ITEM	BASIC DESCRIPTION	PART NUMBER	QTY	USED ON	ILLUSTRATION
1	Bolt M6 x 20 Grade 8.8	BMS030	1	Expansion tank bracket to chassis	
2	Self-tapping 1/4" x 3/4"	SPT14234	1	Expansion tank to bracket	
3	Expansion bracket	BMS020	4	3M radiator bracket	
4	Bolt M6 x 16 with square neck	BST10724	4	Fan brackets to fan	
5	Expansion bracket	SPE00210	4	Fan to radiator cooling - 20 1000	
6	Washer M6 x 16	M0705	8	4 x Fan to radiator 4 x 20 radiator bracket	
7	Plain Nut M6	M0705	8	Radiator bobbin	
8	Washer Nut 1/4"	WPT114	1	Expansion tank bracket	
9	Plain Washer 1/4" Heavy duty	WPH114	13	8 x SIV red bracket 4 x Fan bearings 1 x Expansion tank bracket	
10	Plain Washer 1/4" Heavy duty	WPH114	4	Radiator bobbin back	
11	Plain Washer 1/4" Heavy duty	SMS21102	4	Radiator bobbin front	

x1

x1

x1

x1

Pack D		CATERHAM		44	
		PACK NUMBER		SICCATB	
COOLING SIGMA					
This pack may include extra fasteners to cover different options					
ITEM	BASIC DESCRIPTION	PART NUMBER	QTY	USED ON	ILLUSTRATION
12	Plain Washer 1/4" x 3/4" Heavy duty	WPH114214	1	Expansion tank bracket	
13	Spring Washer S16 Heavy duty	WSP16117	9	8 x Radiator bobbin 1 x Expansion tank	
14	Washer Clip 1/4" 20mm	WST10240	6	2 x 4 Fan bearing 2 x 4 Fan bearing 2 x Radiator bobbin back	
15	Washer Clip 1/4" 20mm	WST10230	2	1 x Engine outlet to top 1 engine 1 x Engine outlet to bottom 1 engine	
16	Washer Clip 1/4" 20mm	WST10225	18	2 Fan bearings 2 Fan bearings 2 Fan bearings 2 Fan bearings	
17	Washer Clip 1/4" 20mm	WST10156	6	Expansion tank small 1 piece	
18	Washer - Black 1/4" x 3/4"	WST101015	12	Cowling flap	

x1

x1

x4

## TIPS

Lay the plate over the top of the chassis until the hole sits in the middle of the tube; mark and drill.  
Vincent M

Throw away the red cap that came on the expansion bottle.  
Lloyd D

# DRY SUMP FITTING THE EXPANSION BOTTLE

DRY SUMP

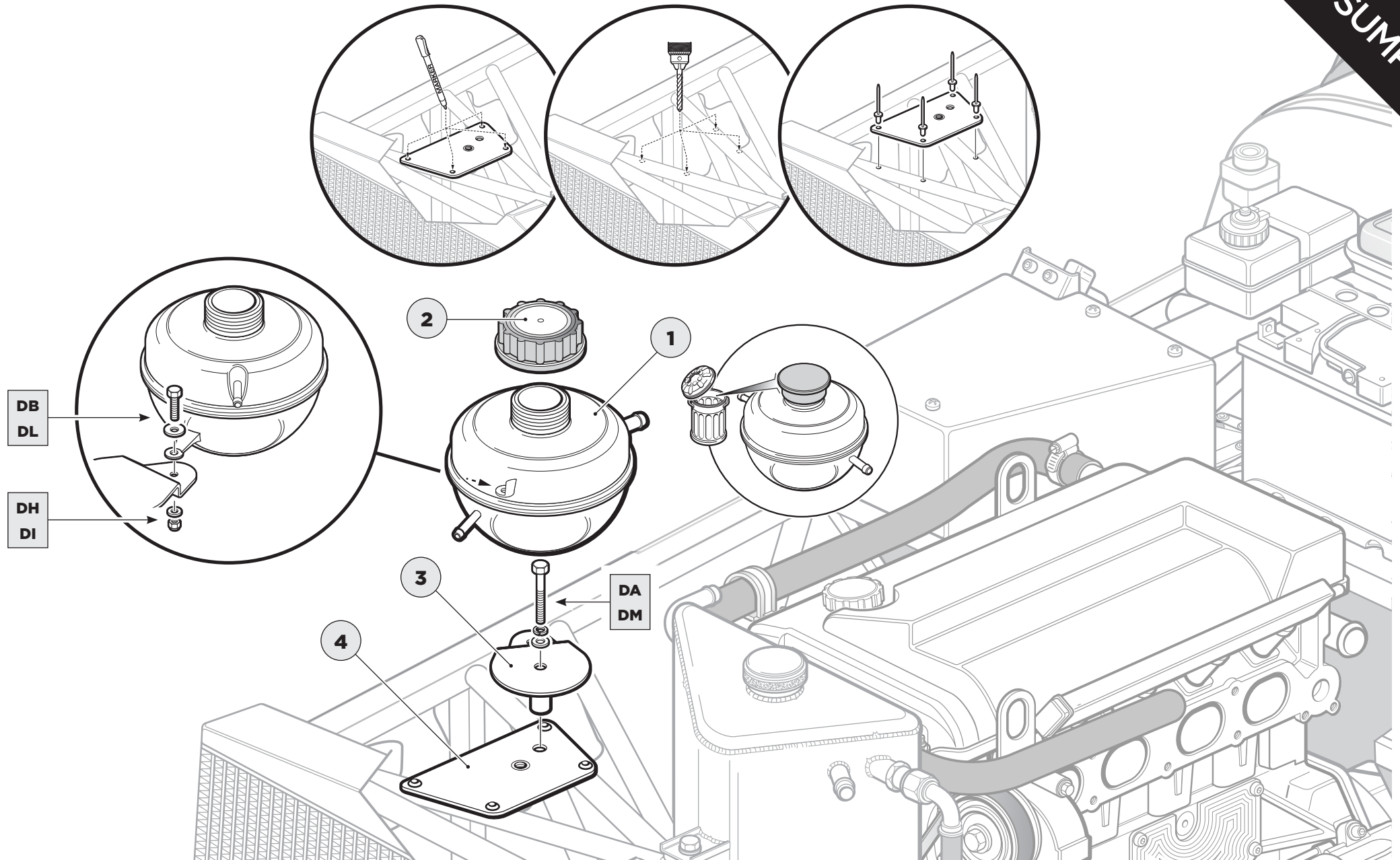

# DRY SUMP LOWER RADIATOR HOSE

## PARTS

- 1 Lower radiator hose

## TOOLS

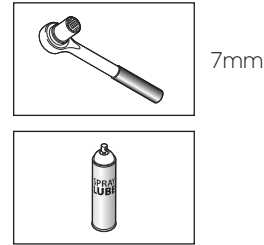

## FIXINGS

Pack D		CATERHAM		44	
ITEM		BASIC DESCRIPTION	PART NUMBER	QTY	USED ON
1	DA	Roll Mat 2.25" (56mm) x 3.5"	888440	1	Expansion tank bracket to chassis
2	DB	Roll Mat 1.5" (38mm) x 3.5"	887442/4	1	Expansion tank to bracket
3	DC	Roll Mat 1.5" (38mm) x 3.5"	888420	4	SM radiator bracket
4	DD	Roll Mat 2" (51mm) Square Section	887102/4	4	Fan brackets to fan
5	DE	Roll Mat 1.5" (38mm) x 3.5"	888420/10	4	Fan to radiator mounting - 20 (10x)
6	DF	Plan Nut M8	888776	8	4x Fan to radiator and 2x Expansion tank bracket
7	DG	Plan Nut M8	888776	8	Radiator bobbin
8	DH	Plan Nut M8	887114	1	Expansion tank bracket
9	DI	Plan Washer 16 (16mm) x 16 (16mm) x 2 (2mm)	888114	13	13 x 16 Fan brackets 4 x 16 Fan brackets 1 x Expansion tank bracket
10	DJ	Plan Washer 16 (16mm) x 16 (16mm) x 2 (2mm)	888114	4	Radiator bobbin back
11	DK	Plan Washer 16 (16mm) x 16 (16mm) x 2 (2mm)	888114/10	4	Radiator bobbin front

Drawings are for illustrative purposes only and are not to scale. Page 1 of 2

Pack D		CATERHAM		44	
ITEM		BASIC DESCRIPTION	PART NUMBER	QTY	USED ON
12	DL	Plan Washer 16 (16mm) x 16 (16mm) x 2 (2mm)	888114/10	1	Expansion tank bracket
13	DM	Spring Washer 16 (16mm) x 16 (16mm)	888114/10	8	8 x Radiator bobbin 1 x Expansion tank
14	DN	Hose Clip 20 (20mm)	80725-40	6	2 x 16 shape hose to upper rail 2 x 2 Fan radiator hose 2 x 2 Bottom radiator hose
15	DO	Hose Clip 20 (20mm)	80723-30	2	1 x Engine outlet to top 1 frame 1 x Engine outlet to lower frame
16	DP	Hose Clip 17 (17mm)	80710-25	18	6 Radiator bobbin 12 Fan frames 6 Expansion tank 4 Fan frames 1 x Dry Sump
17	DD	Hose Clip 16 (16mm)	80710-16	6	Expansion tank small T piece
18	DR	Plan - Blank 17 (17mm) x 17 (17mm)	88710-17	12	Coupling cap

Drawings are for illustrative purposes only and are not to scale. Page 1 of 2

x2

## TIPS

Reminder for later on – nip up once the car has been run.  
**Mick F**

Support hose by cable tying to chassis rails. Make sure they are clear of the steering rack.  
**Grant P**

Fit the hose to the larger outlet on the engine.  
**Dan D**

# DRY SUMP LOWER RADIATOR HOSE

DRY SUMP

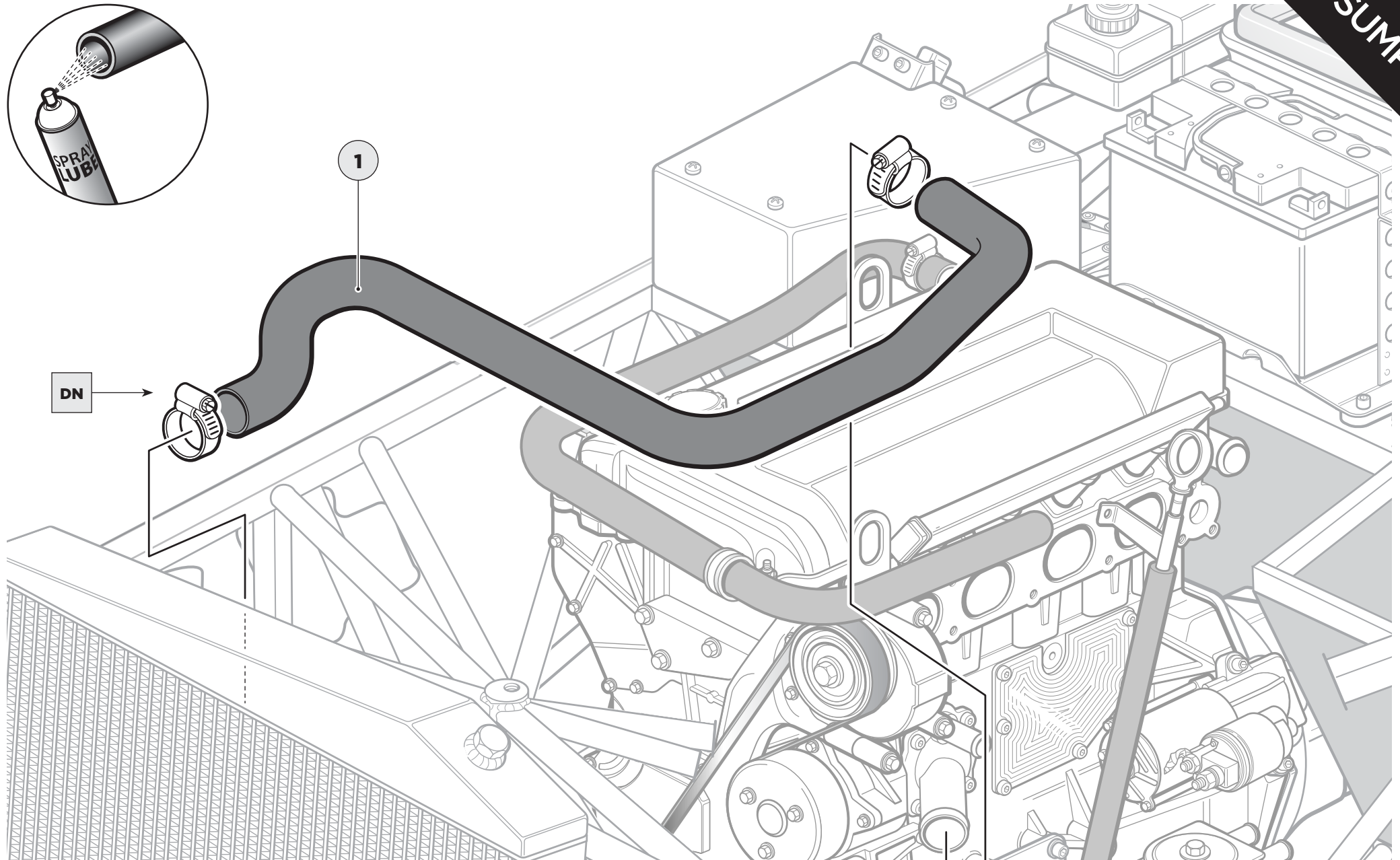

# DRY SUMP UPPER RADIATOR HOSE

## PARTS

- 1 Upper radiator hose

## TOOLS

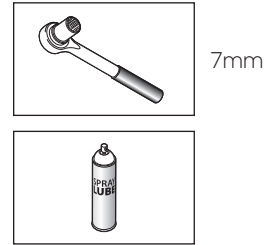

## FIXINGS

Pack D		CATERHAM		44	
		PACK NUMBER		SICCATB	
COOLING SIGMA					
This pack may include extra fasteners to cover different options					
ITEM	BASIC DESCRIPTION	PART NUMBER	QTY	USED ON	ILLUSTRATION
1	DN Rail Kit 2.0 (Hose Kit)	888640	1	Expansion tank bracket to chassis	
2	DB Fanway 1.8 (Hose Kit)	887142/4	1	Expansion tank to bracket	
3	DC Radiator 88120 (Hose Kit)	888620	4	SM radiator bracket	
4	DD Rail Kit 2.0 with Square Section	882102/4	4	Fan brackets to fan	
5	DE Radiator 88120 Fanway 1.8	888620/10	4	Fan to radiator mounting - 20 (top)	
6	DF Fanway 1.8 (Hose Kit)	883170	8	1/4 Fan to radiator and DV radiator bracket	
7	DG Plain Nut M8	880770	8	Radiator bobbin	
8	DH Fanway 1.8 (Hose Kit)	887110	1	Expansion tank bracket	
9	DI Plain Washer 16 (Hose Kit)	889110	13	16 x DV Fan Bracket 16 x Fan Brackets 1 x Expansion tank bracket	
10	DJ Plain Washer 16 (Hose Kit)	889110	4	Radiator bobbin back	
11	DK Plain Washer 16 (Hose Kit)	889110/20	4	Radiator bobbin front	

Drawings are for illustrative purposes only and are not to scale. Page 1 of 2

Pack D		CATERHAM		44	
		PACK NUMBER		SICCATB	
COOLING SIGMA					
This pack may include extra fasteners to cover different options					
ITEM	BASIC DESCRIPTION	PART NUMBER	QTY	USED ON	ILLUSTRATION
12	DL Plain Washer 16 (Hose Kit)	889110/20	1	Expansion tank bracket	
13	DM Spring Washer 16 (Hose Kit)	889110/10	8	8 x Radiator bobbin 1 x Expansion tank	
14	DN Hose Clip 20 (Hose Kit)	80725-40	6	2 x 1/4 shape hose to water rail 2 x Top radiator hose 2 x Bottom radiator hose	
15	DD Hose Clip 20 (Hose Kit)	80723-20	2	1 x Engine outlet to top 1 Engine 1 x Engine outlet to bottom (top)	
16	DP Hose Clip 17 (Hose Kit)	80710-20	18	6 Radiator bobbin 16 Fan Brackets 1 x DV Hose Kit	
17	DD Hose Clip 16 (Hose Kit)	80710-16	6	Expansion tank small 1 piece	
18	DR Hex - Black 12 (Hose Kit)	887010/10	12	Coupling cap	

Drawings are for illustrative purposes only and are not to scale. Page 1 of 2

x2

## TIPS

Reminder for later on – nip up once the car has been run.  
Mick F

# DRY SUMP UPPER RADIATOR HOSE

DRY SUMP

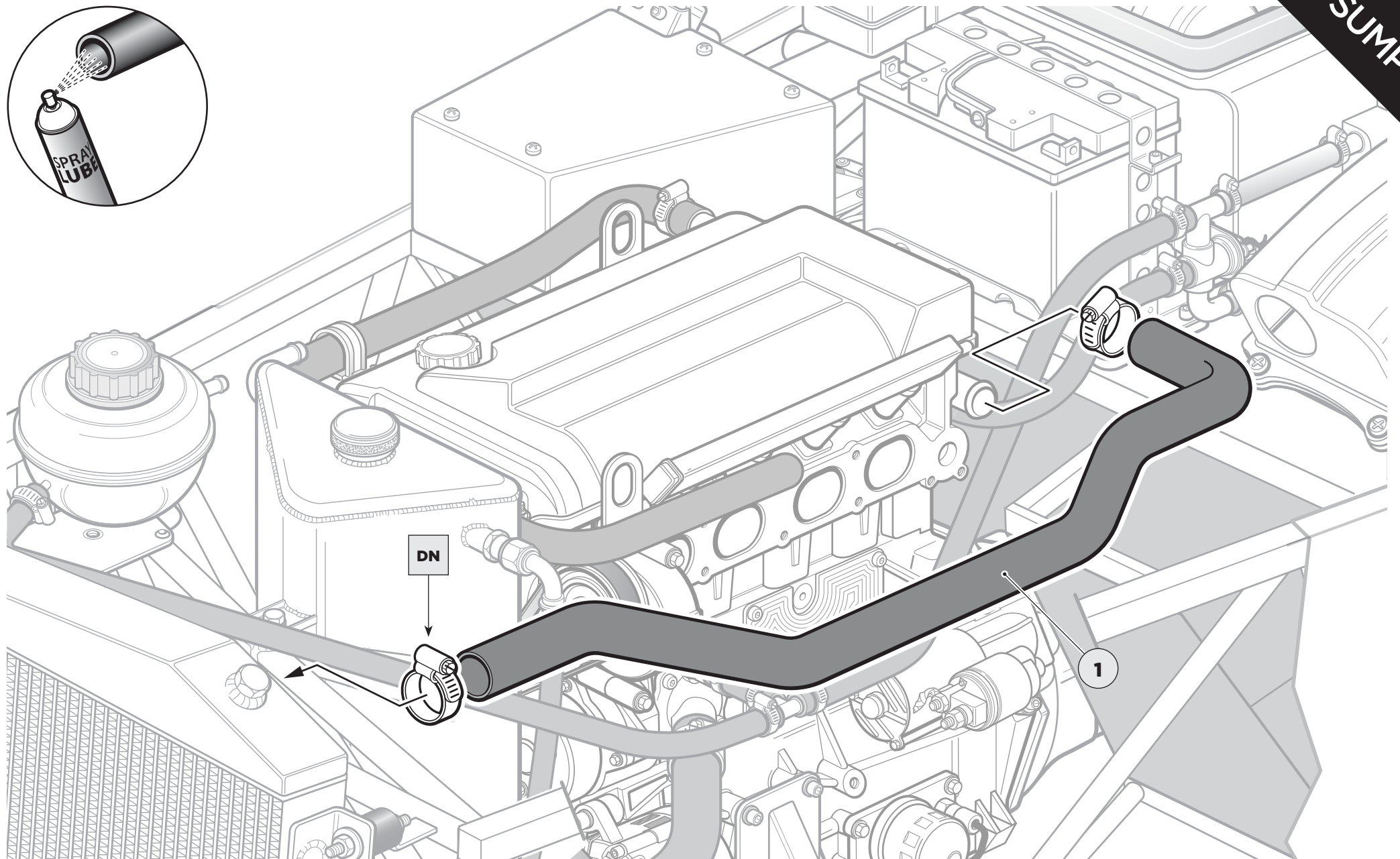
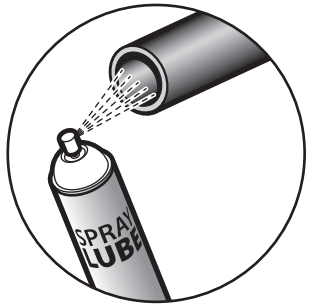

# DRY SUMP HOSES

## PARTS

- 1** T-piece
- 2** Hose roll
- 3** Reducer hose

## TOOLS

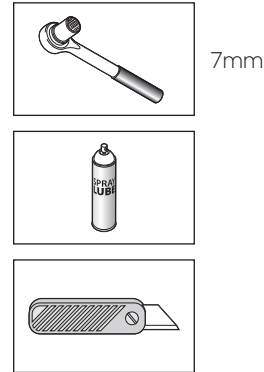

## FIXINGS

Pack <b>D</b>		<b>CATERHAM</b>		44	
		PACK NUMBER		SICCATB	
COOLING SIGMA					
This pack may include extra fasteners to cover different options					
ITEM	BASIC DESCRIPTION	PART NUMBER	QTY	USED ON	ILLUSTRATION
1	Roll Mat 2.25 1.5m x 0.4m	888440	1	Expansion tank bracket to chassis	
2	Roll Mat 1.5m 1.5m x 0.4m	887442/4	1	Expansion tank to bracket	
3	Roll Mat 0.9m 0.9m x 0.4m	888420	4	SM radiator bracket	
4	Roll Mat 0.18 0.18m x 0.18m	887102/4	4	Fan brackets to fan	
5	Roll Mat 0.9m 0.9m x 0.4m	888441/4	4	Fan to radiator bracket	
6	Roll Mat 0.9m 0.9m x 0.4m	888441/4	8	4 Fan to radiator bracket	
7	Roll Mat 0.9m 0.9m x 0.4m	888441/4	8	Radiator bobbin	
8	Roll Mat 0.9m 0.9m x 0.4m	887104	1	Expansion tank bracket	
9	Roll Mat 0.9m 0.9m x 0.4m	888441/4	13	13 x 0.9m Fan brackets 4 x 0.9m Fan brackets 1 x Expansion tank bracket	
10	Roll Mat 0.9m 0.9m x 0.4m	888441/4	4	Radiator bobbin back	
11	Roll Mat 0.9m 0.9m x 0.4m	888441/4	4	Radiator bobbin front	

Drawings are for illustrative purposes only and are not to scale. Page 1 of 2

Pack <b>D</b>		<b>CATERHAM</b>		44	
		PACK NUMBER		SICCATB	
COOLING SIGMA					
This pack may include extra fasteners to cover different options					
ITEM	BASIC DESCRIPTION	PART NUMBER	QTY	USED ON	ILLUSTRATION
12	Roll Mat 0.9m 0.9m x 0.4m	888441/4	1	Expansion tank bracket	
13	Roll Mat 0.9m 0.9m x 0.4m	888441/4	8	8 x Radiator bobbin 1 x Expansion tank	
14	Roll Mat 0.9m 0.9m x 0.4m	88720/40	6	2 x 0.9m Fan brackets 2 x 0.9m radiator hose 2 x 0.9m radiator hose	
15	Hose Clip 22 - 25mm	88723/38	2	1 x Engine outlet to big T-piece 1 x Engine outlet to radiator inlet	
16	Hose Clip 17 - 22mm	88716/25	18	6 x Radiator hoses 1 x Expansion tank 4 x Dry Sump 4 x Radiator	
17	Hose Clip 8 - 10mm	88718/16	6	Expansion tank small T-piece	
18	Roll - Black 0.75m x 0.15m	88718/16	12	Covering cap	

Drawings are for illustrative purposes only and are not to scale. Page 1 of 2

x1  
x7

## TIPS

You will need to cut hoses to size.

John S

The hose that comes from the engine reduces in diameter to the T-piece.

Chris N

# DRY SUMP HOSES

DRY SUMP

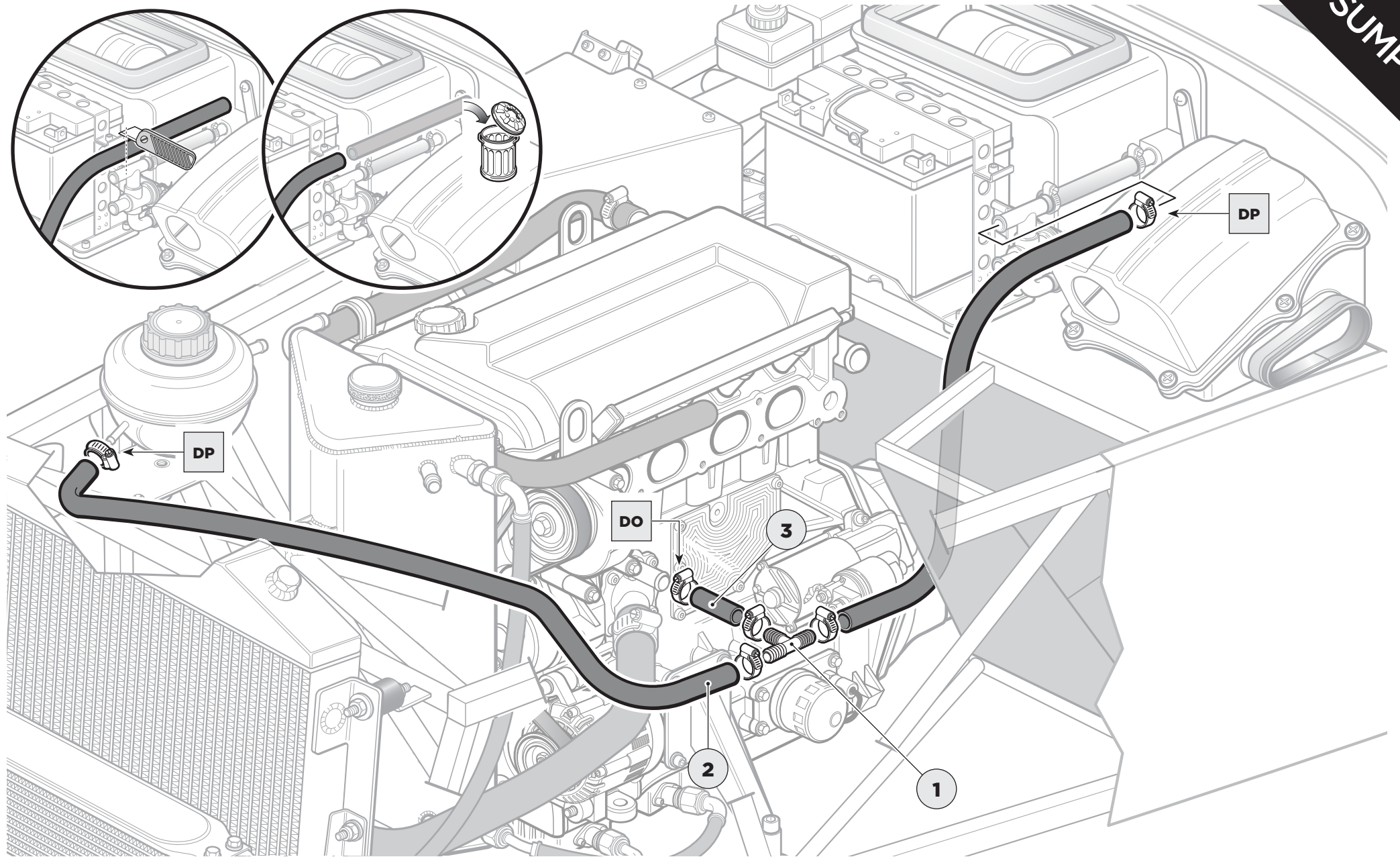

# DRY SUMP CATCH TANK

## PARTS

- 1 Silicone hose 90°

## TOOLS

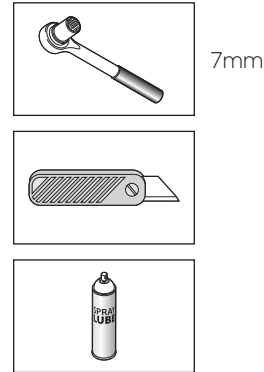

## FIXINGS

Pack D		CATERHAM		44	
		PACK NUMBER		QUANTITY	
<b>COOLING SIGMA</b>					
<i>This pack may include extra fasteners to cover different options</i>					
ITEM	BASIC DESCRIPTION	PART NUMBER	QTY	USED ON	ILLUSTRATION
1	EA Expansion tank to chassis	888440	1	Expansion tank to chassis	
2	EA Expansion tank to bracket	88714224	1	Expansion tank to bracket	
3	EA 3M radiator bracket	888420	4	3M radiator bracket	
4	EA Fan brackets to fan	88710724	4	Fan brackets to fan	
5	EA Fan to radiator mounting - 30 100g	88842110	4	Fan to radiator mounting - 30 100g	
6	EA Fan to radiator 44 100 radiator bracket	888174	8	Fan to radiator 44 100 radiator bracket	
7	EA Radiator bobbin	888174	8	Radiator bobbin	
8	EA Expansion tank bracket	887114	1	Expansion tank bracket	
9	EA 18 x 10V Fan bracket 44 100 Fan bracket 1 x Expansion tank bracket	888114	13	18 x 10V Fan bracket 44 100 Fan bracket 1 x Expansion tank bracket	
10	EA Radiator bobbin back	888174	4	Radiator bobbin back	
11	EA Radiator bobbin front	888174	4	Radiator bobbin front	

Drawings are for illustrative purposes only and are not to scale. Page 1 of 2

Pack D		CATERHAM		44	
		PACK NUMBER		QUANTITY	
<b>COOLING SIGMA</b>					
<i>This pack may include extra fasteners to cover different options</i>					
ITEM	BASIC DESCRIPTION	PART NUMBER	QTY	USED ON	ILLUSTRATION
12	EA Expansion tank bracket	888114	1	Expansion tank bracket	
13	EA Spring Washer 44 100mm	888114	8	4 x Radiator bobbin 1 x Expansion tank	
14	EA Hose Clip 44 100mm	8871040	6	2 x 44 100mm hose to radiator hose 2 x Radiator bobbin hose	
15	EA Hose Clip 44 100mm	8871040	2	1 x Engine outlet to top 1 100mm 1 x Engine outlet to bottom 100mm	
16	EA Hose Clip 44 100mm	8871040	18	8 x Radiator bobbin 1 x Expansion tank 4 x Dry Sump 4 x Radiator	
17	EA Hose Clip 44 100mm	8871040	6	Expansion tank small 7 piece	
18	EA Rod - Black 1000mm	8871040	12	Crossing Rod	

Drawings are for illustrative purposes only and are not to scale. Page 1 of 2

x3

## TIPS

The silicone hose you are looking for has a 90° one end and then a long piece.

Chris B

The hose itself should have a grey lining.

James S

Put hose through P-Clip and attach to tank.

Grant P

Use the excess to run from tank to D-Bottle.

Vincent M

# DRY SUMP CATCH TANK

DRY SUMP

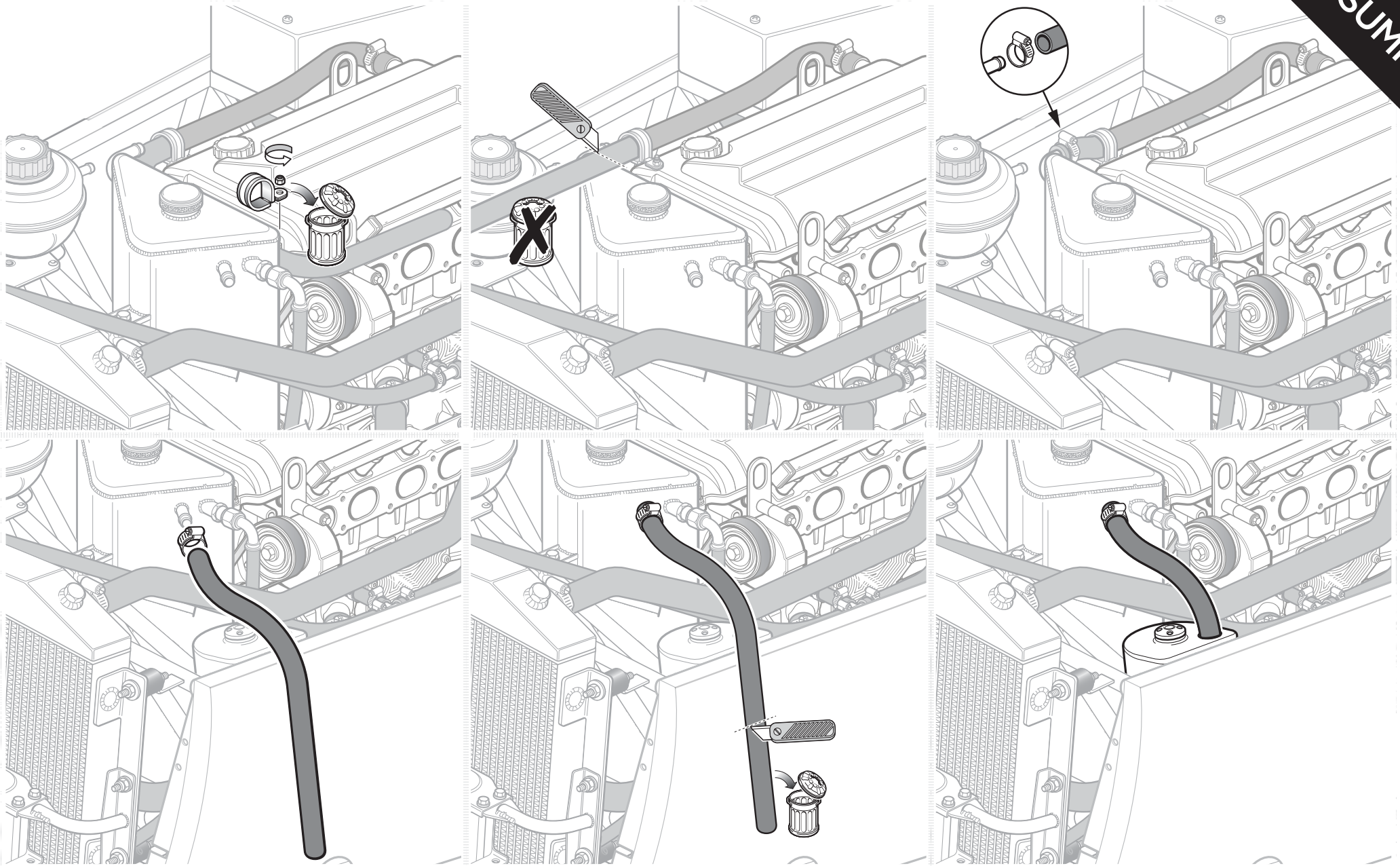

## DRY SUMP OIL PIPE - 1 OF 3

### PARTS

**1** Oil pipe - 39C059

### TOOLS

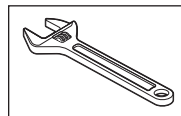

### FIXINGS

### TIPS

The pipe will fit both ways but you don't want any kinks in the pipe itself – one way will fit better.

**Tiago O**

Put copper slip on the threads.

**Rich T**

Tighten by hand slowly and give a small 'nip' up.

**Chris B**

Take care not to cross thread.

**Anthony L**

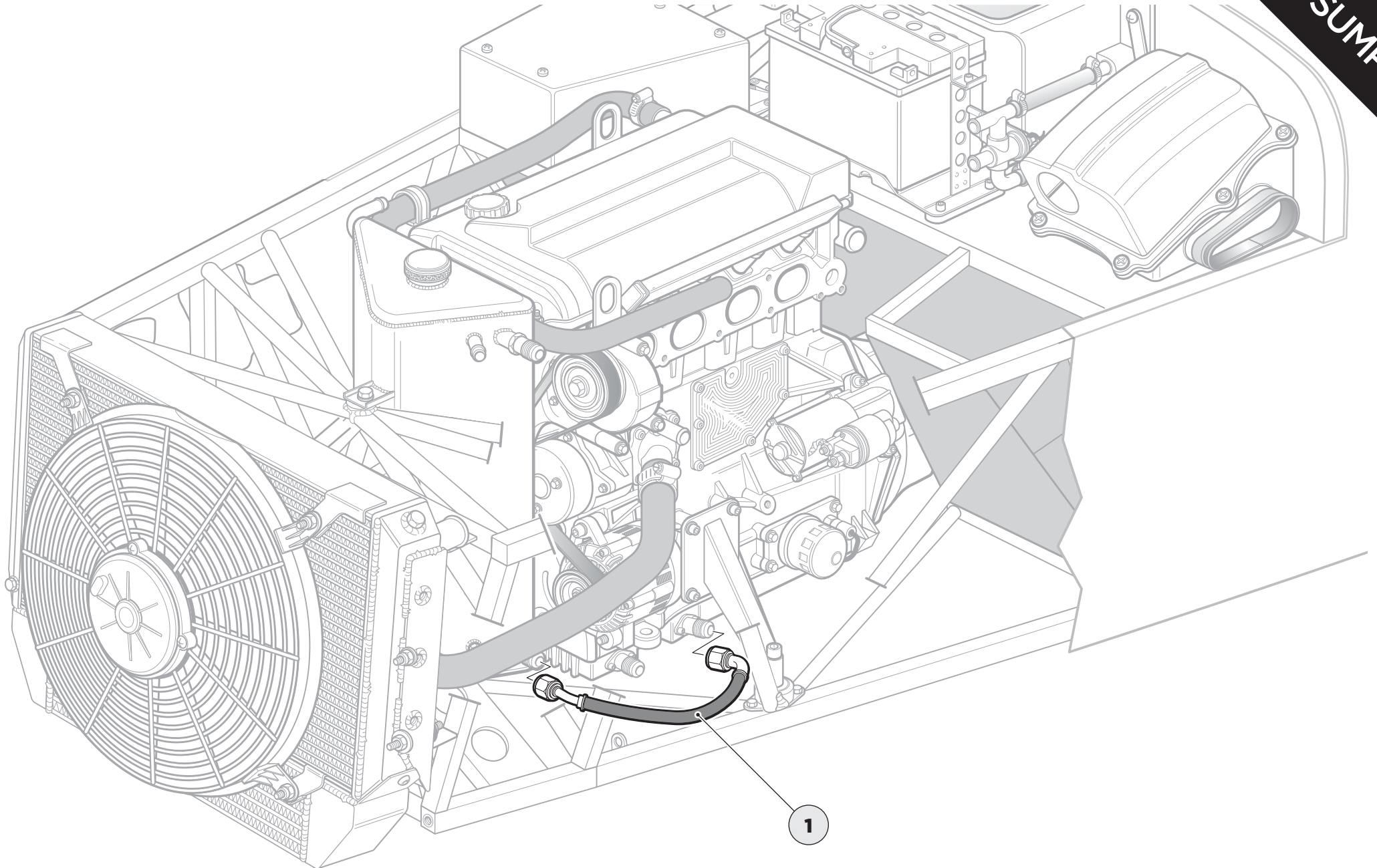

## DRY SUMP OIL PIPE - 2 OF 3

### PARTS

**1** Oil pipe - 39C060

### TOOLS

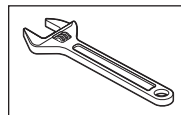

### FIXINGS

### TIPS

The pipe will fit both ways but you don't want any kinks in the pipe itself – one way will fit better.

**Tiago O**

Put copper slip on the threads.

**Rich T**

Tighten by hand slowly and give a small 'nip' up.

**Chris B**

Take care not to cross thread.

**Anthony L**

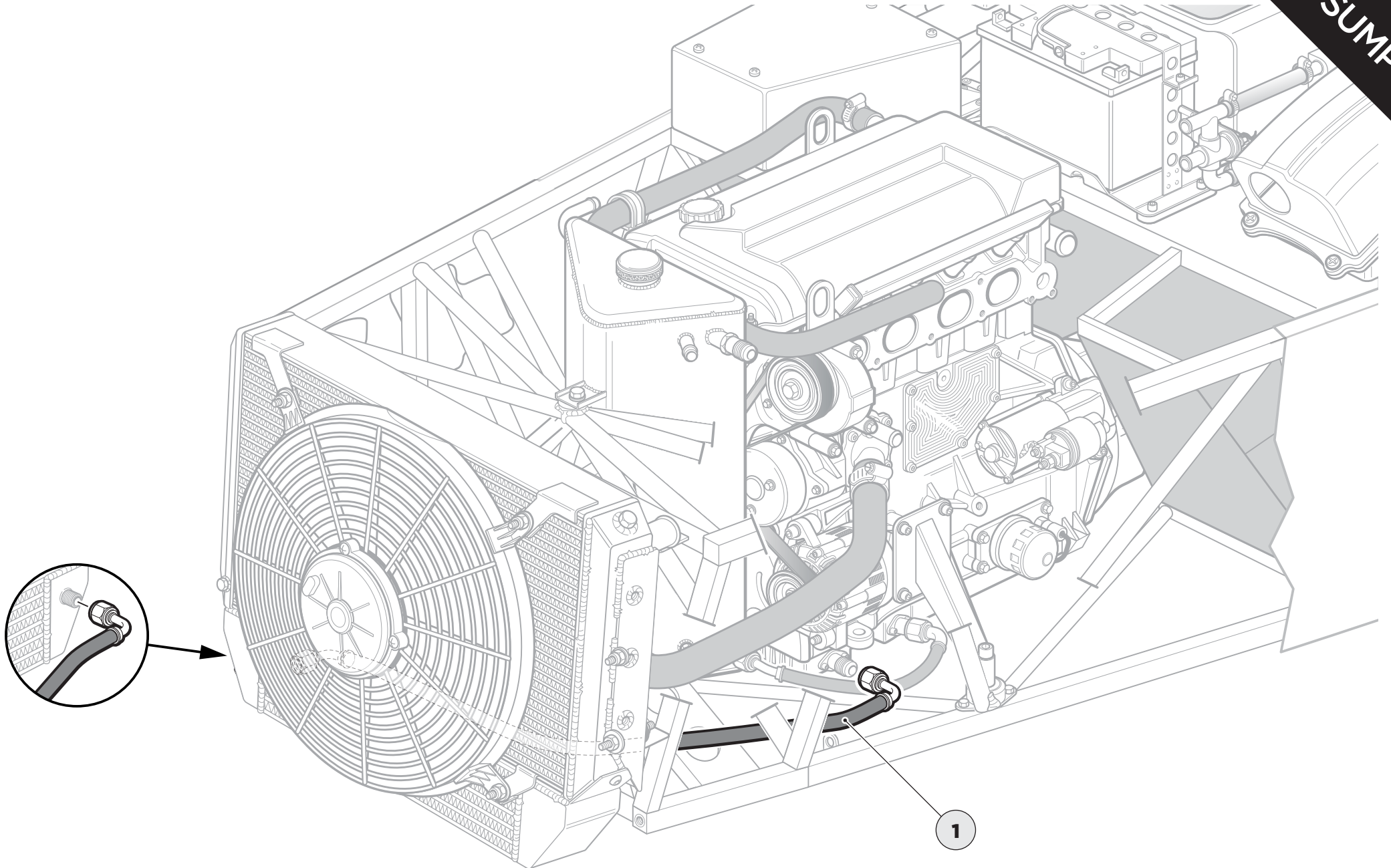

## DRY SUMP OIL PIPE - 3 OF 3

### PARTS

- 1** Oil pipe -

### TOOLS

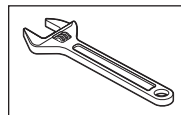

### FIXINGS

### TIPS

The pipe will fit both ways but you don't want any kinks in the pipe itself – one way will fit better.

**Tiago O**

Put copper slip on the threads.

**Rich T**

Tighten by hand slowly and give a small 'nip' up.

**Chris B**

Take care not to cross thread.

**Anthony L**

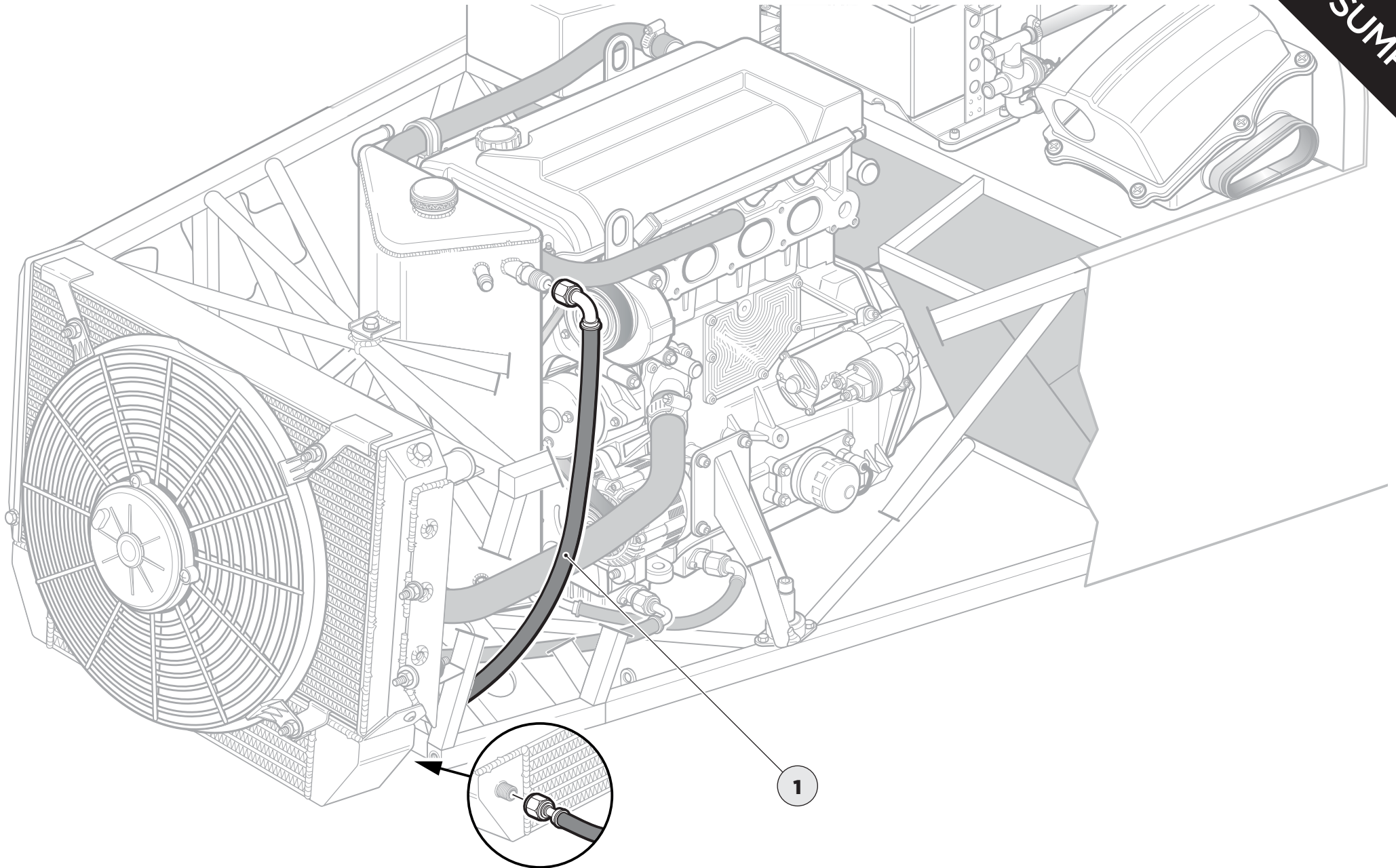

## WET / DRY SUMP - A BIT OF SUB-ASSEMBLY (SOME HOSES NEED MODIFYING)

### PARTS

- 1 Silicone hoses

### TOOLS

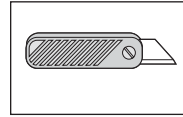

### FIXINGS

### TIPS

Don't throw away the long piece of hose after cutting.

**Rich T**

# WET / DRY SUMP - A BIT OF SUB-ASSEMBLY (SOME HOSES NEED MODIFYING)

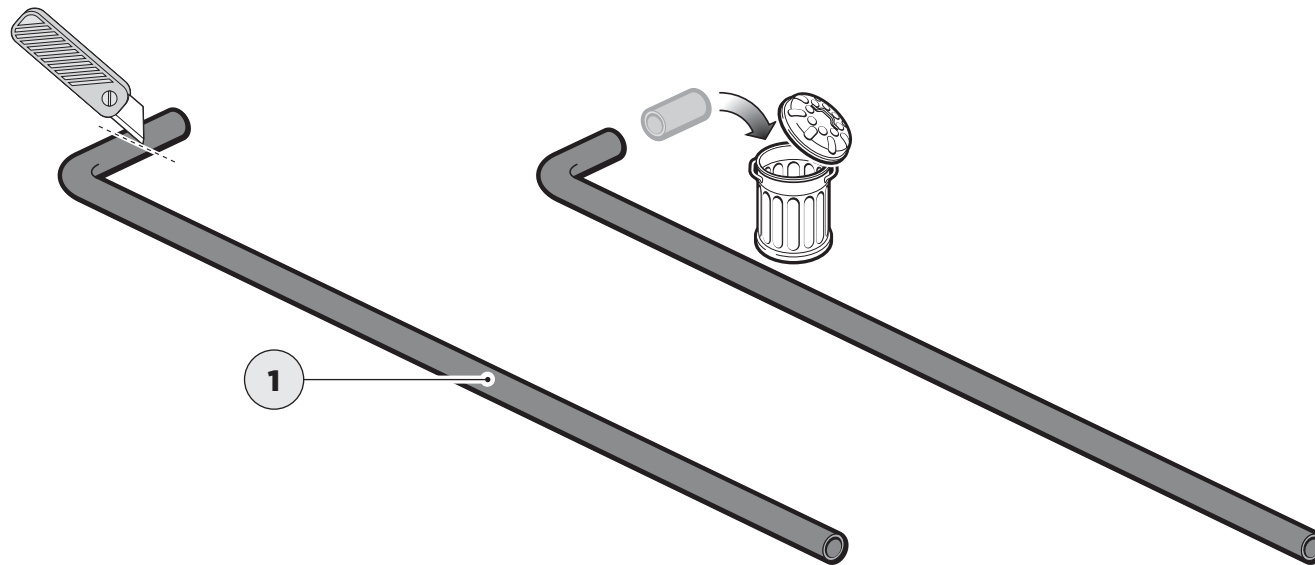
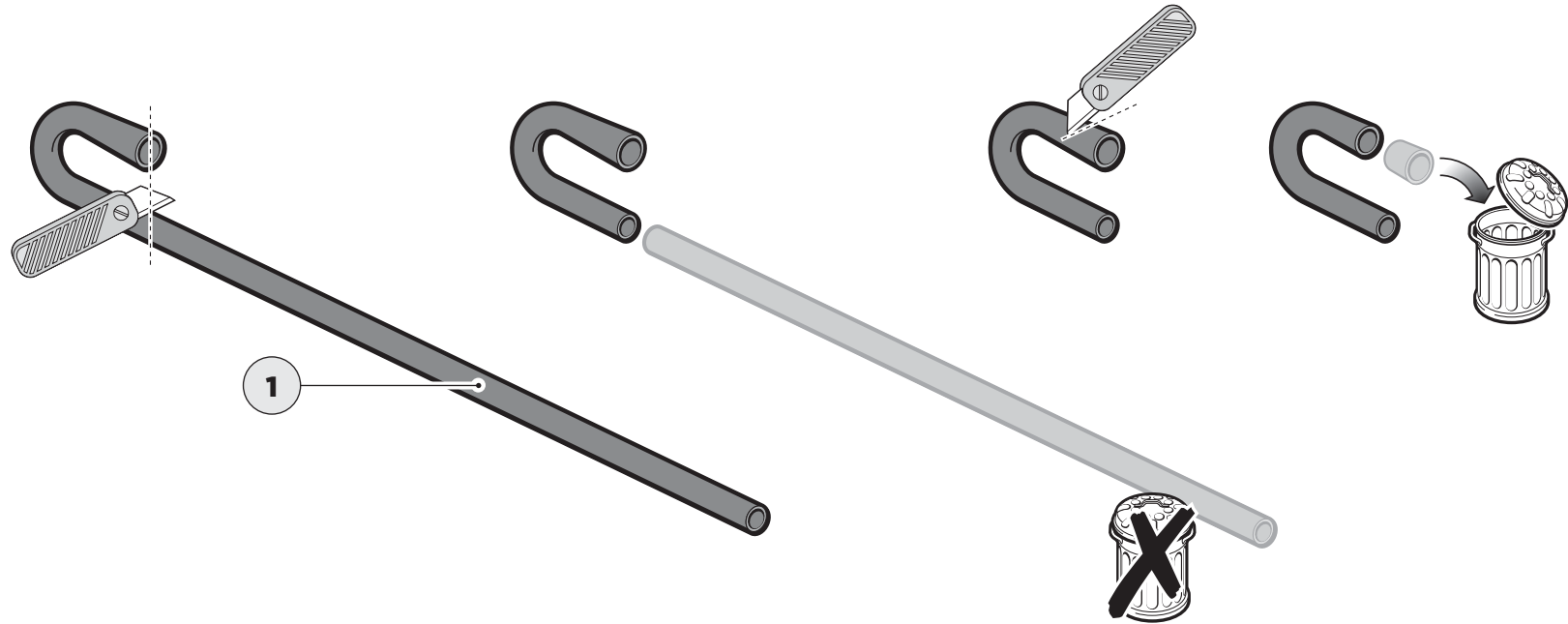

# WET / DRY SUMP SUB-ASSEMBLY - TEMPERATURE SENSOR

## PARTS

- 1** Temperature sender
- 2** Earth tag
- 3** Cooling submarine

## TOOLS

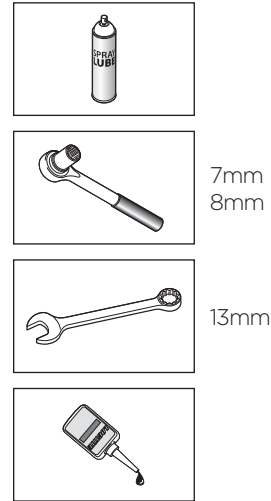

## FIXINGS

Pack <b>D</b>		<b>CATERHAM</b>		44	
		PACK NUMBER		SICCATB	
COOLING SIGMA					
This pack may include extra fasteners to cover different options					
ITEM	BASIC DESCRIPTION	PART NUMBER	QTY	USED ON	ILLUSTRATION
1	Ball Nut 2.00 Hex 2.0	888440	1	Expansion tank bracket to chassis	
2	Washer 1.50 X 2.0	887142/4	1	Expansion tank to bracket	
3	Submarine 88200 Hex 2.0	888420	4	SM radiator bracket	
4	Ball Nut 2.00 Square neck	882102/4	4	Fan brackets to fan	
5	Submarine 88210 Hex 2.0	888421/2	4	Fan to radiator mounting - 20 100g	
6	Washer 1.50 Hex 2.0	88817/4	8	4x Fan to radiator 4x 20 radiator bracket	
7	Plain Nut 3.00	88877/4	8	Radiator bobbin	
8	Washer 1.50 Hex 2.0	88711/4	1	Expansion tank bracket	
9	Plain Washer 1.50 Hex 2.0	88811/4	13	13 x 20 Fan bracket 4 x 2 Fan brackets 1 x Expansion tank bracket	
10	Plain Washer 1.50 Hex 2.0	88811/2	4	Radiator bobbin back	
11	Plain Washer 1.50 Hex 2.0	88811/2/2	4	Radiator bobbin front	

Drawings are for illustrative purposes only and are not to scale. Page 1 of 2

Pack <b>D</b>		<b>CATERHAM</b>		44	
		PACK NUMBER		SICCATB	
COOLING SIGMA					
This pack may include extra fasteners to cover different options					
ITEM	BASIC DESCRIPTION	PART NUMBER	QTY	USED ON	ILLUSTRATION
12	Plain Washer 1.50 Hex 2.0	88811/2/2/2	1	Expansion tank bracket	
13	Spring Washer 1.50 Hex 2.0	88819/2	8	8 x Radiator bobbin 1 x Expansion tank	
14	Washer 1.50 Hex 2.0	88720/40	6	2 x 1 x where hoses connect to 2 x 2 radiator hose 2 x Radiator bobbin hose	
15	Washer 1.50 Hex 2.0	88720/30	2	1 x Engine outlet to top 1 engine 1 x Engine outlet to bottom 1 engine	
16	Hose Clip 17.25mm	80116-25	18	6 x Radiator bracket 1 x Expansion tank 4 x Dry Sump 4 x Submarine	
17	Washer 1.50 Hex 2.0	88719/4	6	Expansion tank small 1 piece	
18	Washer 1.50 Hex 2.0	88719/1/1/1	12	Cooling fan	

Drawings are for illustrative purposes only and are not to scale. Page 1 of 2

x2

## TIPS

Use a drop of Loctite on the sender.

Tiago O

Be careful not to over-tighten the sender.

Jamie A

# WET / DRY SUMP SUB-ASSEMBLY - TEMPERATURE SENSOR

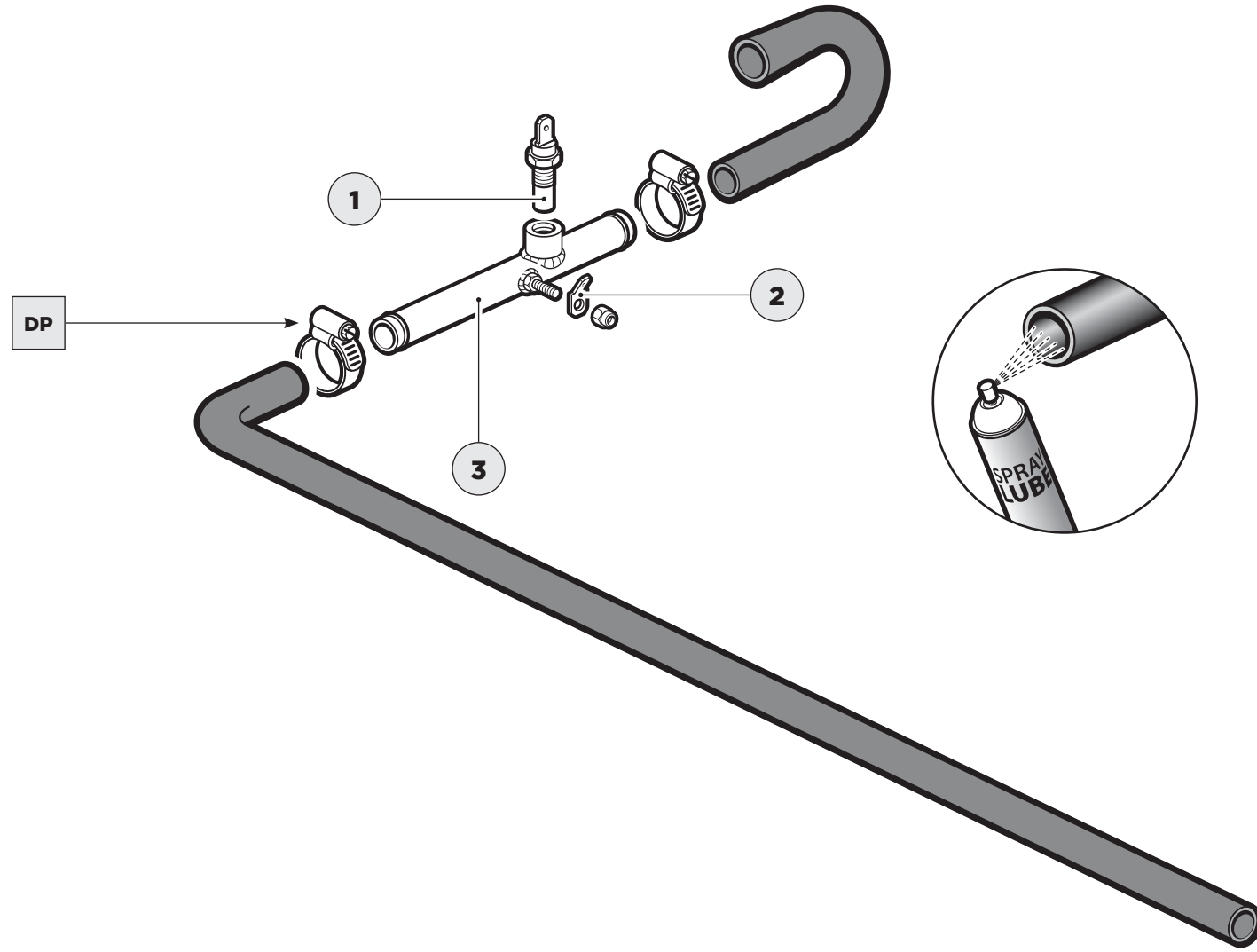

# WET / DRY SUMP SUBMARINE

## PARTS

**1** Submarine assembly

## TOOLS

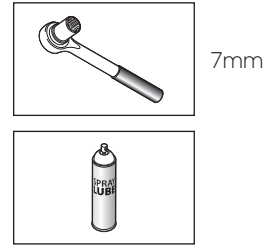

## FIXINGS

Pack <b>D</b>		<b>CATERHAM</b>		44	
		PACK NUMBER		SICCATB	
COOLING SIGMA					
This pack may include extra fasteners to cover different options					
ITEM	BASIC DESCRIPTION	PART NUMBER	QTY	USED ON	ILLUSTRATION
1	DA Bolt M6 x 20 Hex Hd	888440	1	Expansion tank bracket to chassis	
2	DB Washer 1.6 x 5.4	887142/4	1	Expansion tank to bracket	
3	DC Submarine 88520 Hex Hd	888420	4	SM radiator bracket	
4	DD Bolt M6 x 18 with Square neck	887107/4	4	Fan brackets to fan	
5	DE Submarine 88516 Hex Hd	888421/2	4	Fan to radiator mounting - 20 100g	
6	DF Hex Nut M6	88877/8	8	44 Fan to radiator and 20 radiator bracket	
7	DG Plain Nut M6	88877/8	8	Radiator bobbin	
8	DH Hex Nut M4	88711/4	1	Expansion tank bracket	
9	DI Plain Washer 16 Hex Hd	88811/4	13	18 x 50V rad bracket 4 x 4 Fan Brackets 1 x Expansion tank bracket	
10	DJ Plain Washer 16 Hex Hd	88811/4	4	Radiator bobbin back	
11	DK Plain Washer 16 Hex Hd	888211/2/2	4	Radiator bobbin front	

Drawings are for illustrative purposes only and are not to scale. Page 1 of 2

Pack <b>D</b>		<b>CATERHAM</b>		44	
		PACK NUMBER		SICCATB	
COOLING SIGMA					
This pack may include extra fasteners to cover different options					
ITEM	BASIC DESCRIPTION	PART NUMBER	QTY	USED ON	ILLUSTRATION
12	DL Plain Washer 16 Hex Hd	88811/2/2	1	Expansion tank bracket	
13	DM Spring Washer 16 Hex Hd	88811/2	8	8 x Radiator bobbin 1 x Expansion tank	
14	DN Hex Clip 20 Hex Hd	88720/40	6	2 x 18 where hoses connect to 2 x 20 radiator hose 2 x 20 radiator tank	
15	DO Hose Clip 22 - 26mm	88723/26	2	1 x Engine outlet to big 1 piece 1 x Engine outlet to heater inlet	
16	DP Hose Clip 17 - 20mm	88716/25	18	8 x Radiator bobbin 1 x Expansion tank 4 x Dry Sump 4 x Radiator	
17	DD Hose Clip 8 - 10mm	88716/8	6	Expansion tank small 1 piece	
18	DR Bolt - Black 12.9 x 100	88716/100	12	Cooling fan	

Drawings are for illustrative purposes only and are not to scale. Page 1 of 2

x1  
x1

## TIPS

# WET / DRY SUMP SUBMARINE

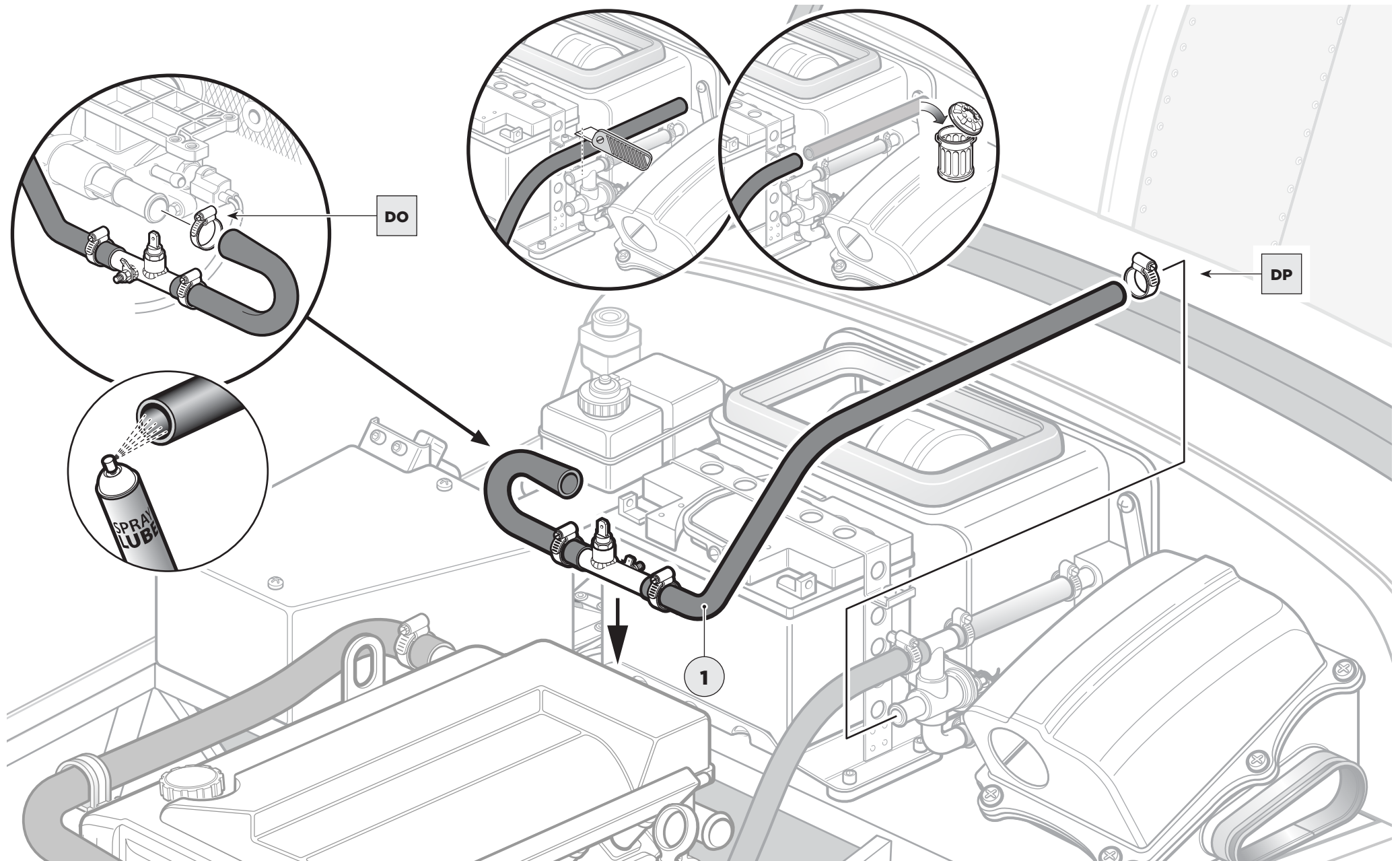

# WET SUMP LAST BIT OF PLUMBING

## PARTS

**1** 5/16" hose

## TOOLS

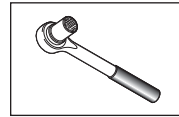

7mm



## FIXINGS

Pack <b>D</b>		<b>CATERHAM</b>		44	
		PACK NUMBER		QUANTITY	
<b>COOLING SIGMA</b>					
<i>This pack may include extra fasteners to cover different options</i>					
ITEM	BASIC DESCRIPTION	PART NUMBER	QTY	USED ON	ILLUSTRATION
1	Ball Mt 2-20 Hex Nut	888440	1	Expansion tank bracket to chassis	
2	Ball Mount 1/2" X 3/4"	88714424	1	Expansion tank to bracket	
3	Ball Mount 1/2" Hex Nut	888440	4	SM radiator bracket	
4	Ball Mt 1/2" with Square Washer	8821024	4	Fan brackets to fan	
5	Ball Mount 1/2" Hex Nut	888440	4	Fan to radiator mounting - 20 100g	
6	Hex Nut M8	888795	8	4x Fan to radiator 4x 20 radiator bracket	
7	Plan Nut M8	888795	8	Radiator bobbin	
8	Hex Nut 1/4"	887114	1	Expansion tank bracket	
9	Plan Washer 1/4" Hex Nut	888114	13	8 x 20 Fan bracket 4 x 20 Fan bracket 1 x Expansion tank bracket	
10	Plan Washer 1/4" Hex Nut	888114	4	Radiator bobbin back	
11	Plan Washer 1/4" Hex Nut	888114	4	Radiator bobbin front	

Drawings are for illustrative purposes only and are not to scale. Page 1 of 2

Pack <b>D</b>		<b>CATERHAM</b>		44	
		PACK NUMBER		QUANTITY	
<b>COOLING SIGMA</b>					
<i>This pack may include extra fasteners to cover different options</i>					
ITEM	BASIC DESCRIPTION	PART NUMBER	QTY	USED ON	ILLUSTRATION
12	Plan Washer 1/4" Hex Nut	888114	1	Expansion tank bracket	
13	Spring Washer 1/4" Hex Nut	888114	8	8 x Radiator bobbin 1 x Expansion tank	
14	Hex Clip 1/4" Hex Nut	8872040	6	2 x 14 where hex nut used 4 x 20 radiator hose 2 x Radiator bobbin hose	
15	Hex Clip 1/4" Hex Nut	8872038	2	1 x Engine outlet to top T-piece 1 x Engine outlet to bottom T-piece	
16	Hex Clip 1/4" Hex Nut	8871625	18	6 where attached to the frame 2 Expansion tank 2 Radiator 12 Radiator	
17	Hex Clip 1/4" Hex Nut	887816	5	Expansion tank small T-piece	
18	Hex - Bolt 1/4" Hex Nut	8878111	12	Coupling cap	

Drawings are for illustrative purposes only and are not to scale. Page 1 of 2

x2

## TIPS

Run hose through spare P-Clip.

Dan P

Cut hose to length.

Lee A

# WET SUMP LAST BIT OF PLUMBING

WET SUMP

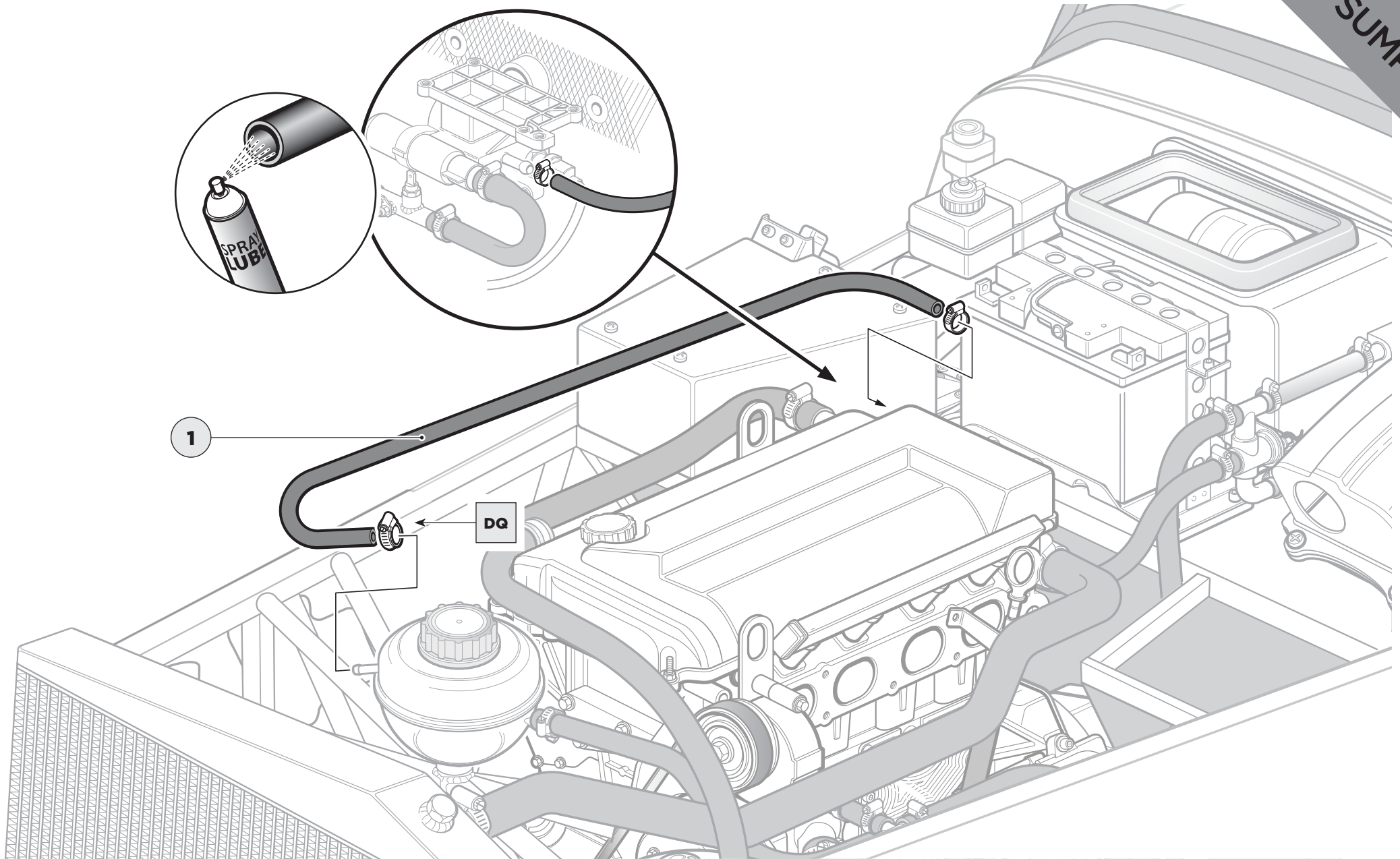

# DRY SUMP LAST BIT OF PLUMBING

## PARTS

**1** 5/16" hose

## TOOLS

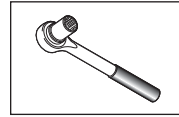

7mm



## FIXINGS

Pack <b>D</b>		<b>CATERHAM</b>		44	
		PACK NUMBER		SIZES/TS	
<b>COOLING SIGMA</b>					
<i>This pack may include extra fasteners to cover different options</i>					
ITEM	BASIC DESCRIPTION	PART NUMBER	QTY	USED ON	ILLUSTRATION
1	Ball Nut 2-20 Hex Nut	888440	1	Expansion tank bracket to chassis	
2	Ball Nut 1/8-27 Hex Nut	887142/4	1	Expansion tank to bracket	
3	Ball Nut 1/8-27 Hex Nut	888420	4	SM radiator bracket	
4	Ball Nut 1/8-27 Hex Nut	887127/4	4	Fan brackets to fan	
5	Ball Nut 1/8-27 Hex Nut	888421/2	4	Fan to radiator bracket - 20 (top)	
6	Ball Nut 1/8-27 Hex Nut	888421/2	5	4th Fan to radiator bracket	
7	Ball Nut 1/8-27 Hex Nut	888421/2	8	Radiator bobbin	
8	Ball Nut 1/8-27 Hex Nut	887124	1	Expansion tank bracket	
9	Ball Nut 1/8-27 Hex Nut	888421/2	13	8 x 10V fan bracket 4 x Fan brgs 1 x Expansion tank bracket	
10	Ball Nut 1/8-27 Hex Nut	888421/2	4	Radiator bobbin back	
11	Ball Nut 1/8-27 Hex Nut	888421/2	4	Radiator bobbin front	

Drawings are for illustrative purposes only and are not to scale. Page 1 of 2

Pack <b>D</b>		<b>CATERHAM</b>		44	
		PACK NUMBER		SIZES/TS	
<b>COOLING SIGMA</b>					
<i>This pack may include extra fasteners to cover different options</i>					
ITEM	BASIC DESCRIPTION	PART NUMBER	QTY	USED ON	ILLUSTRATION
12	Ball Nut 1/8-27 Hex Nut	888421/2	1	Expansion tank bracket	
13	Spring Washer Hex Nut	888421/2	5	8 x Radiator bobbin 1 x Expansion tank	
14	Hex Cap 1/8-27	88720-40	6	2 x 10V fans to bracket 2 x 10V radiator fan to radiator bobbin	
15	Hex Cap 1/8-27	88720-38	2	1 x Engine outlet to top 10V fan 1 x Engine outlet to middle 10V fan	
16	Hex Cap 1/8-27	88716-25	18	8 Radiator bobbin to 10V fans 2 Expansion tank to 10V fans 2 10V fans	
17	Hex Cap 1/8-27	88716-16	5	Expansion tank small T-piece	
18	Hex - Bolt 1/8-27	88716-01/12	12	Cooling fan	

Drawings are for illustrative purposes only and are not to scale. Page 1 of 2

x2

## TIPS

# DRY SUMP LAST BIT OF PLUMBING

DRY SUMP

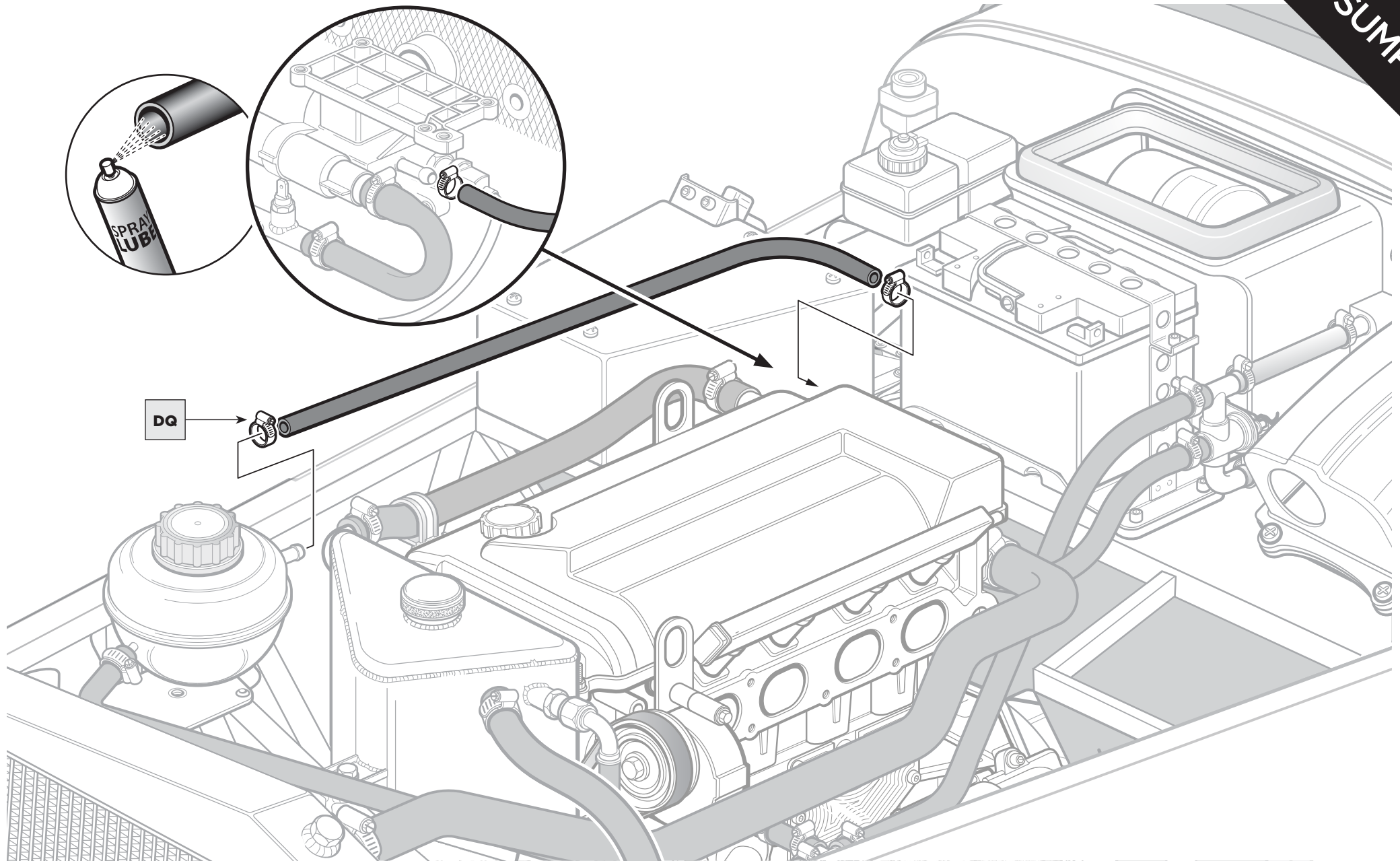

# WET / DRY SUMP PLENUM

## PARTS

**1** Plenum

## TOOLS

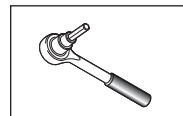

5mm

## FIXINGS

Those removed earlier

## TIPS

Refit the plenum.

**Dan P**

# WET / DRY SUMP PLENUM

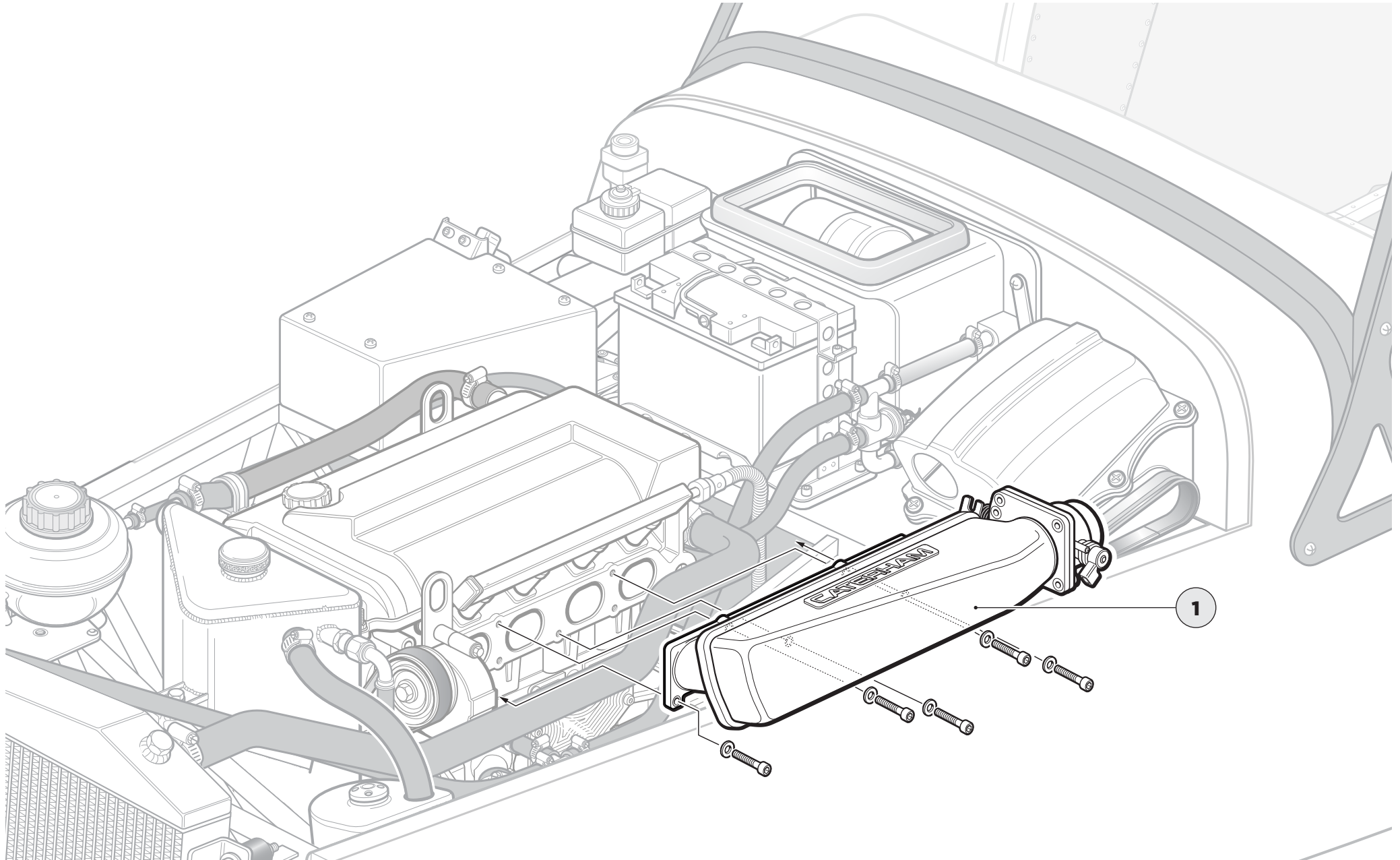

## WET / DRY SUMP AIR BOX HOSE

### PARTS

- 1 Airbox hose
- 2 Hose clip

### TOOLS



7mm

### FIXINGS

All the fixings for this step should be supplied in the airbox.

### TIPS

# WET / DRY SUMP AIR BOX HOSE

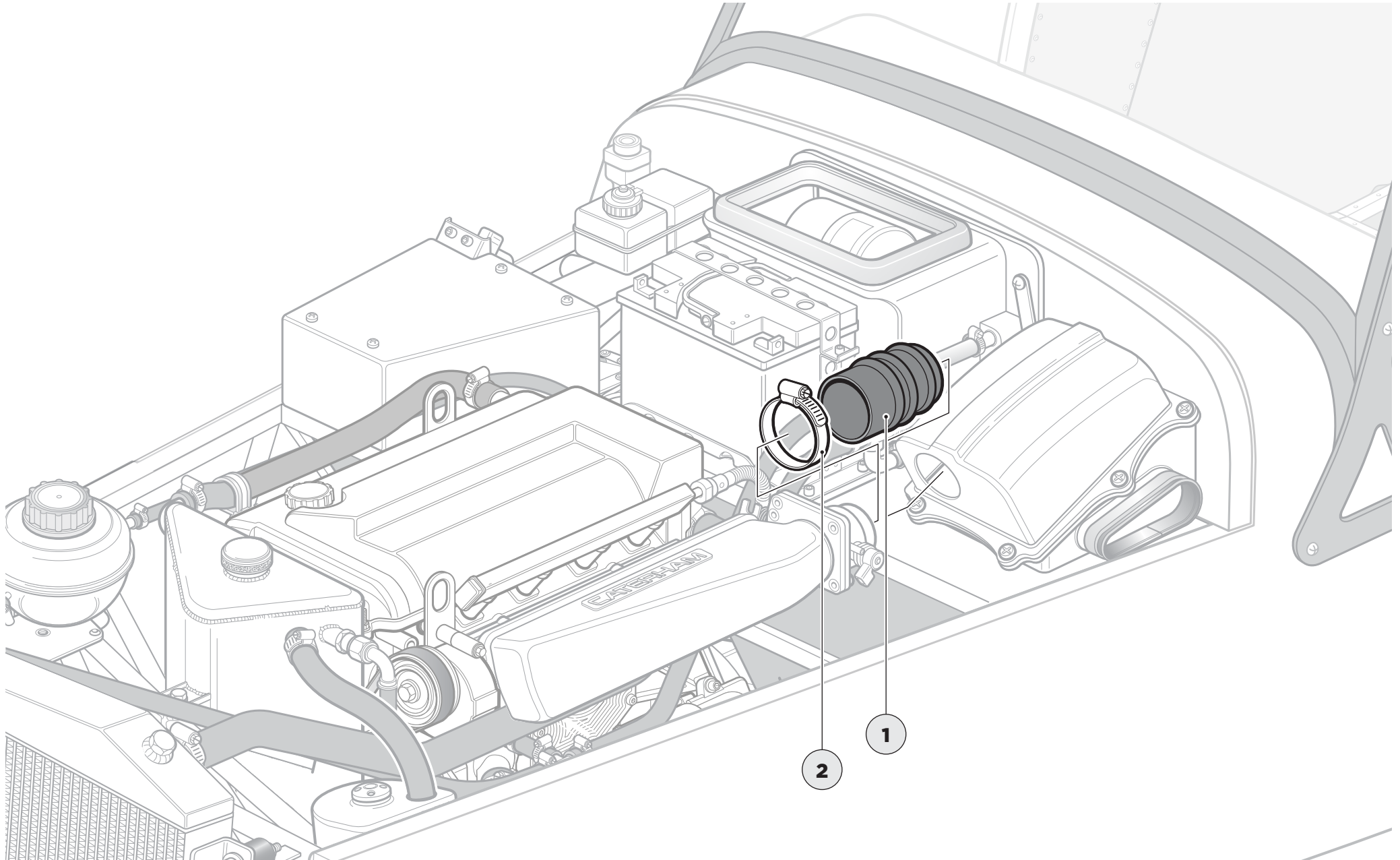

## CONNECTING THE FUEL LINE

---

P A R T S

T O O L S

F I X I N G S

T I P S

## CONNECTING THE FUEL LINE

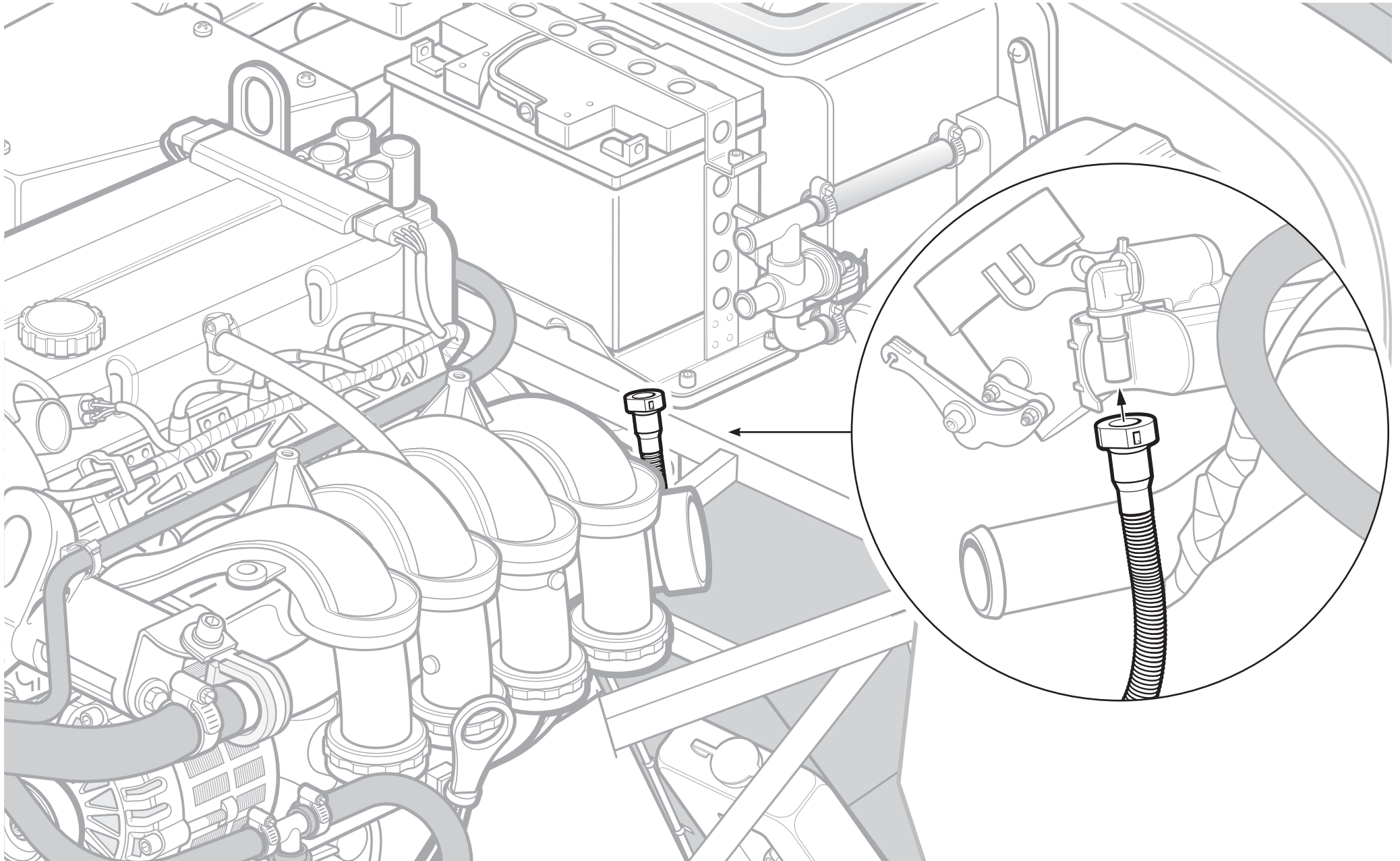

# PROTECTING & ATTACHING THE CLUTCH HOSE

## PARTS

- 1 8mm water hose

## TOOLS

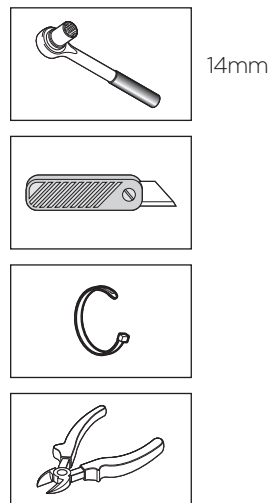

## FIXINGS

## TIPS

Nip up the banjo bolt.

John K

The hose is used to stop chaffing.

James A

## PROTECTING & ATTACHING THE CLUTCH HOSE

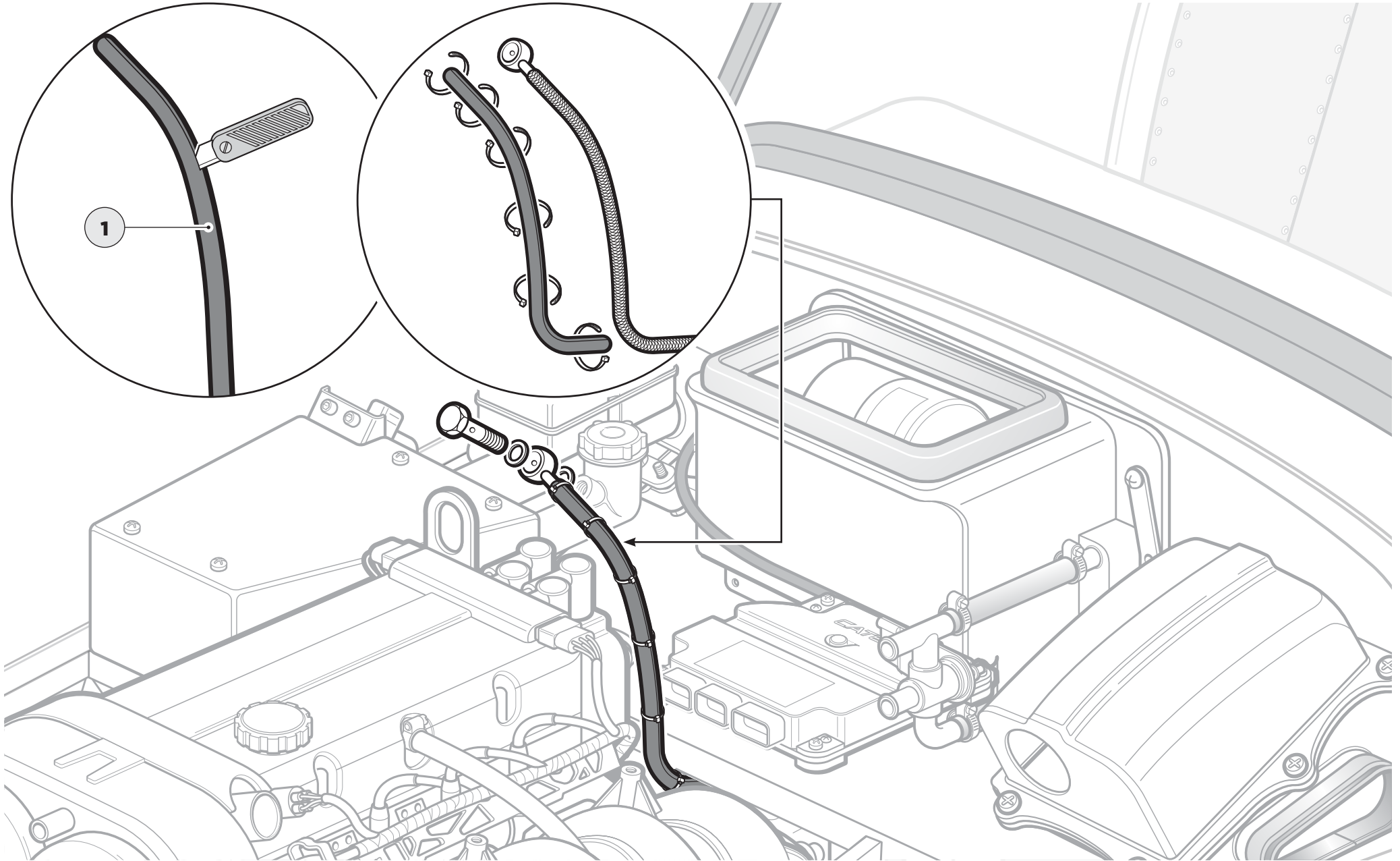

## CONNECTING THE BATTERY (POSITIVE / RED FIRST)

### PARTS

### TOOLS

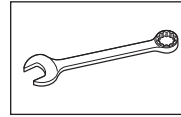

10mm (x2)

### FIXINGS

### TIPS

*Always connect live side of battery first (red wire).*

**Chris B**

*Make the battery the last thing you connect.*

**Jamie A**

*Be careful to ensure that the red leads go to the + side and the black wires to the - side.*

**Dan D**

## CONNECTING THE BATTERY (POSITIVE / RED FIRST)

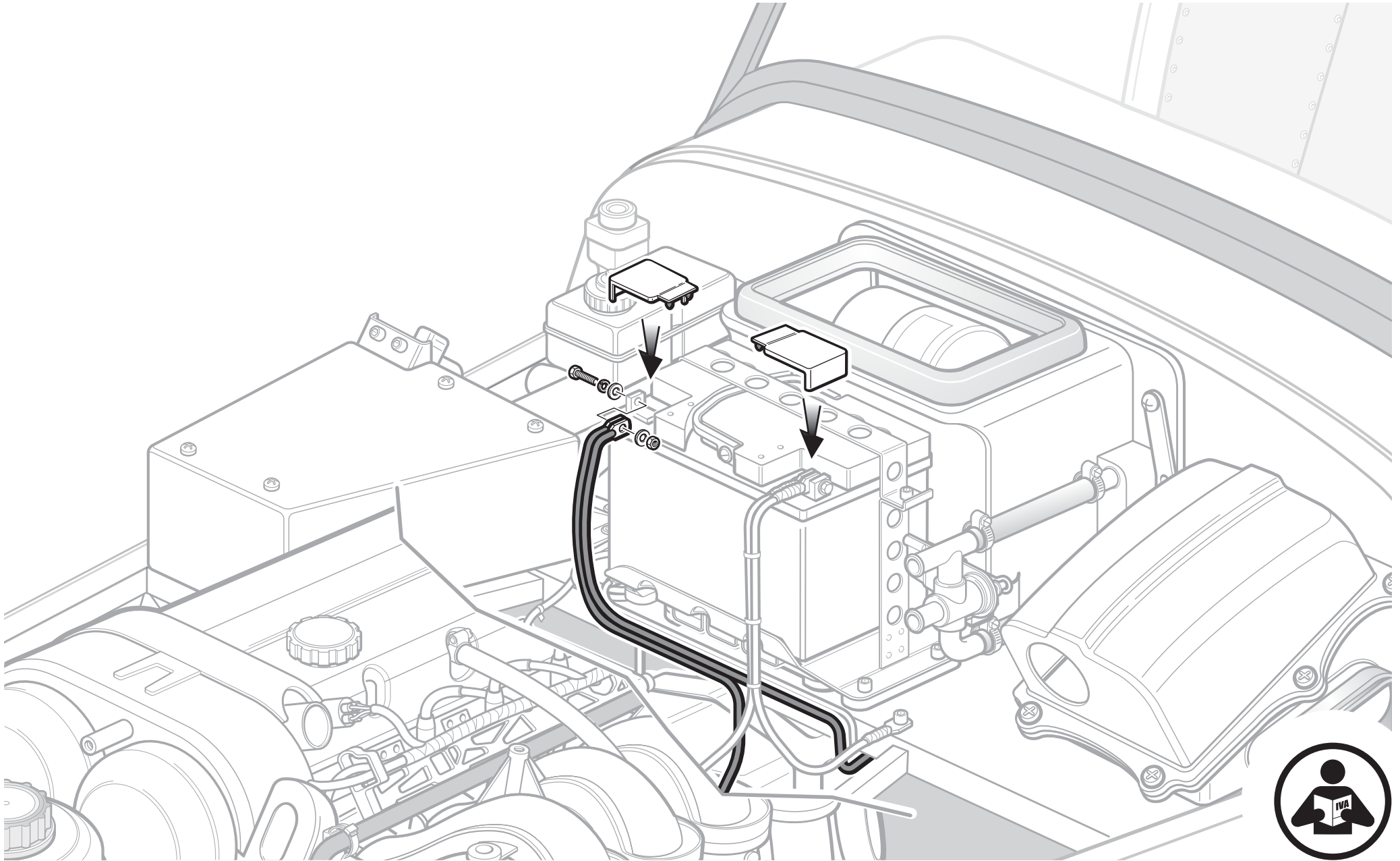

## PARTS

## TOOLS

## FIXINGS

## TIPS

Add a plain M8 or  $\frac{5}{16}$  washer underneath the earth lead to chassis.

**Dan P**

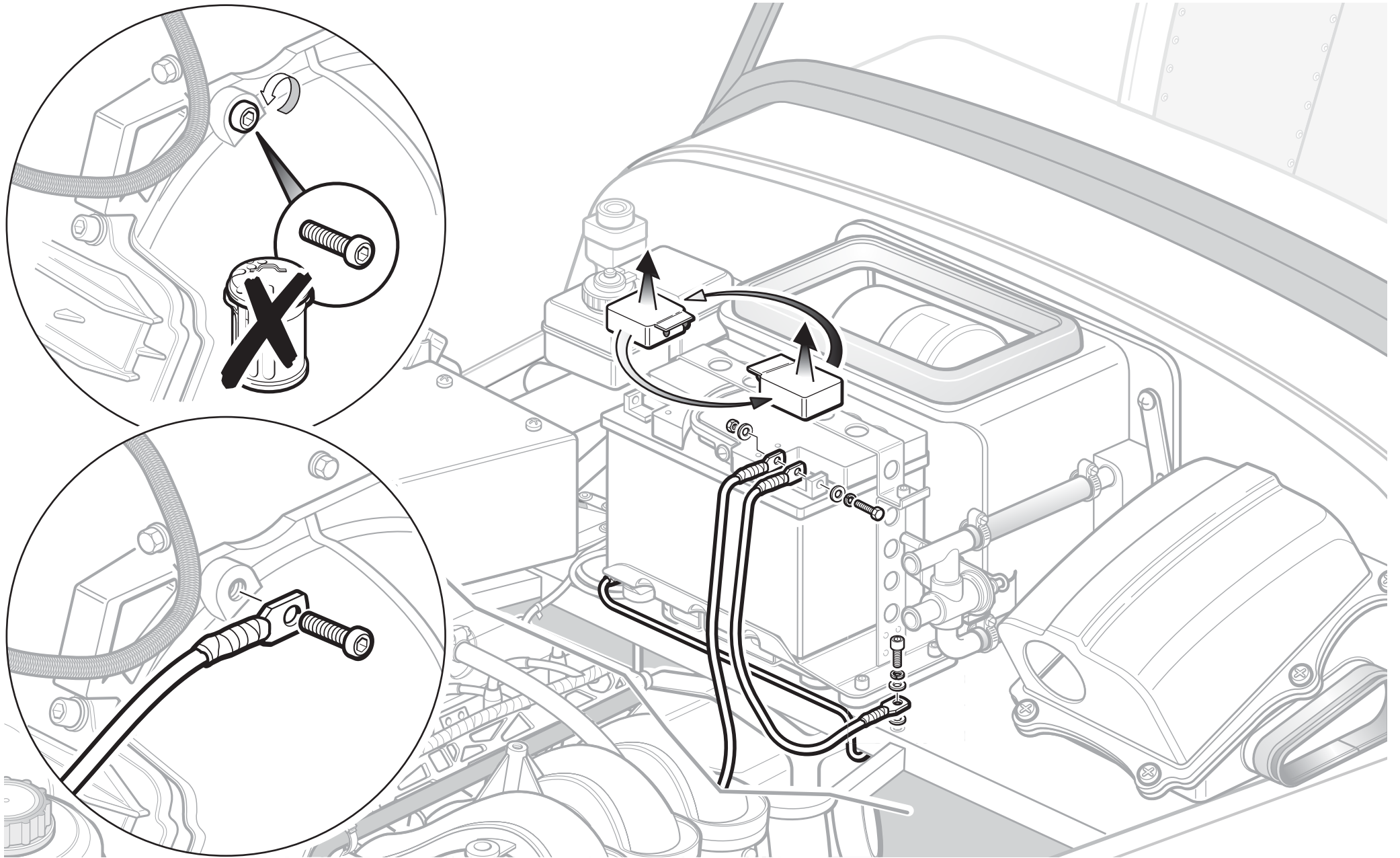

# ONE LAST BIT OF PLUMBING...

## PARTS

**1** Hose

## TOOLS

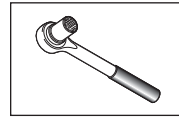

7mm

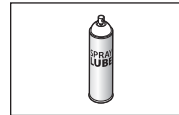
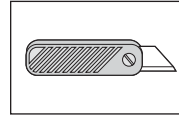

## FIXINGS

Pack <b>D</b>		<b>CATERHAM</b>		44	
		PACK NUMBER		SICCATS	
COOLING SIGMA					
This pack may include extra fasteners to cover different options					
ITEM	BASIC DESCRIPTION	PART NUMBER	QTY	USED ON	ILLUSTRATION
1	EA Radiator 2.50 (Front 2.5)	888440	1	Expansion tank bracket to chassis	
2	EB Radiator 2.50 (Front 2.5)	888440	1	Expansion tank to bracket	
3	EC Radiator 2.50 (Front 2.5)	888440	4	SM radiator bracket	
4	ED Radiator 2.50 (Front 2.5)	888440	4	Fan brackets to fan	
5	EE Radiator 2.50 (Front 2.5)	888440	4	Fan to radiator mounting (2) (top)	
6	EF Radiator 2.50 (Front 2.5)	888440	8	40 Fan to radiator and SV radiator bracket	
7	EG Radiator 2.50 (Front 2.5)	888440	8	Radiator bobbin	
8	DH Radiator 2.50 (Front 2.5)	888440	1	Expansion tank bracket	
9	DI Radiator 2.50 (Front 2.5)	888440	13	18 x SV Fan Bracket 40 x Fan Brackets 1 x Expansion tank bracket	
10	DJ Radiator 2.50 (Front 2.5)	888440	4	Radiator bobbin back	
11	DK Radiator 2.50 (Front 2.5)	888440	4	Radiator bobbin front	

Drawings are for illustrative purposes only and are not to scale. Page 1 of 2

Pack <b>D</b>		<b>CATERHAM</b>		44	
		PACK NUMBER		SICCATS	
COOLING SIGMA					
This pack may include extra fasteners to cover different options					
ITEM	BASIC DESCRIPTION	PART NUMBER	QTY	USED ON	ILLUSTRATION
12	EL Radiator 2.50 (Front 2.5)	888440	1	Expansion tank bracket	
13	EM Radiator 2.50 (Front 2.5)	888440	8	4 x Radiator bobbin 1 x Expansion tank	
14	EN Radiator 2.50 (Front 2.5)	888440	6	2 x 18 x SV Fan Bracket 40 x Fan Brackets 1 x Expansion tank	
15	EO Radiator 2.50 (Front 2.5)	888440	4	1 x Expansion tank to bracket 1 x Fan to radiator mounting 1 x Fan to radiator mounting 1 x Fan to radiator mounting	
16	EP Radiator 2.50 (Front 2.5)	888440	18	18 x Fan Bracket 40 x Fan Brackets 1 x Expansion tank 1 x Dip Switch 1 x Dip Switch	
17	EQ Radiator 2.50 (Front 2.5)	888440	6	Expansion tank small 2 pieces	
18	ER Radiator 2.50 (Front 2.5)	888440	12	Crossing clip	

Drawings are for illustrative purposes only and are not to scale. Page 1 of 2

x1

## TIPS

Cut off hook and trim if required.

Grant P

# ONE LAST BIT OF PLUMBING...

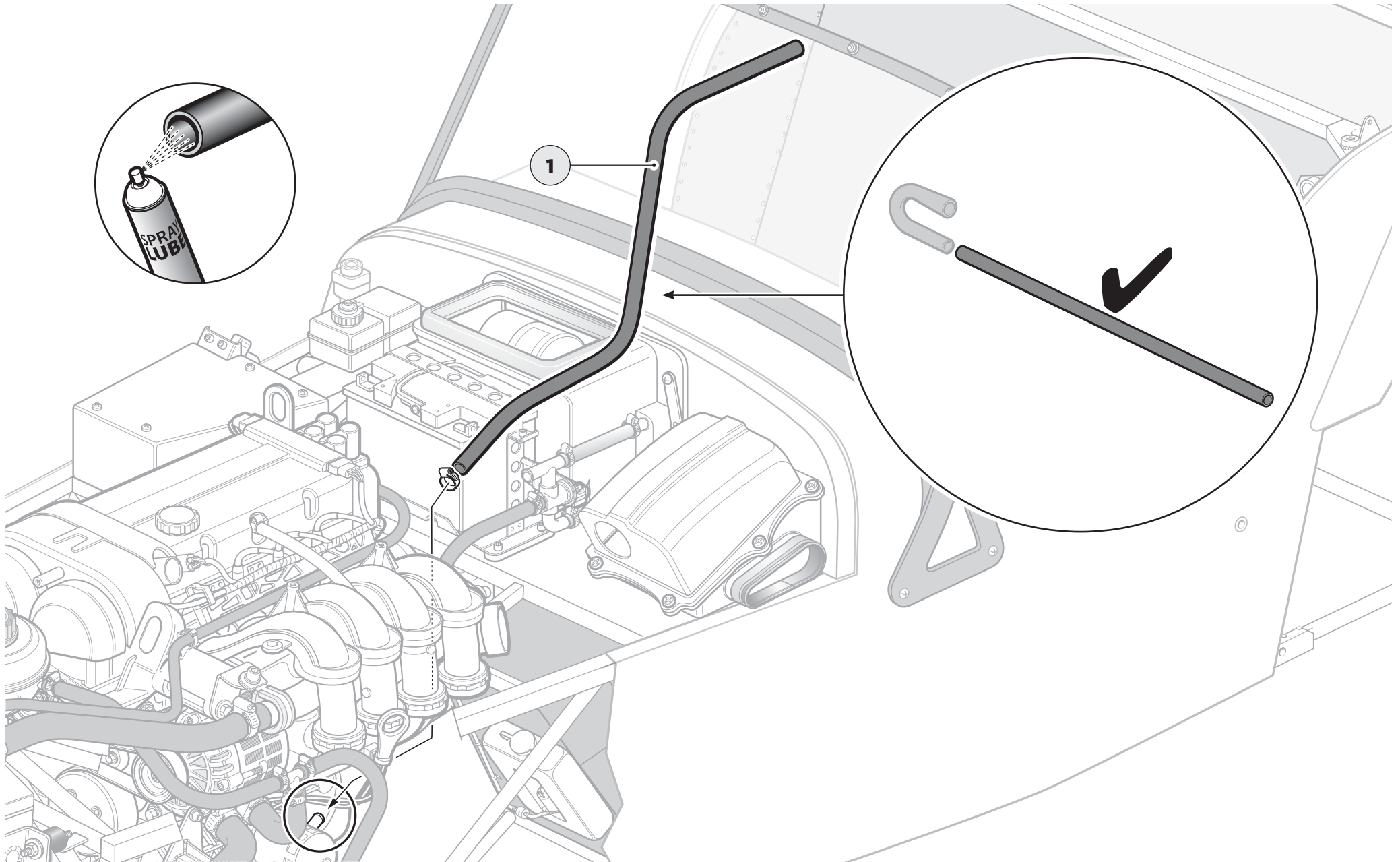

# ...TO CONNECT THE HEATER

## PARTS

## TOOLS



7mm

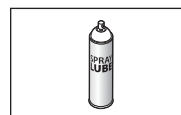

## FIXINGS

## TIPS

Pack <b>D</b>		<b>CATERHAM</b>		44	
		PACK NUMBER		QUANTITY	
<b>COOLING SIGMA</b>					
<i>This pack may include extra fasteners to cover different options</i>					
ITEM	BASIC DESCRIPTION	PART NUMBER	QTY	USED ON	ILLUSTRATION
1	Ball Nut 2.25 Hex 2.8	888440	1	Expansion tank bracket to chassis	
2	Ball Nut 1.50 Hex 2.0	887442/4	1	Expansion tank to bracket	
3	Ball Nut M8x1.25 Hex 1.6	888420	4	SM radiator bracket	
4	Ball Nut 2.00 Hex 2.5	887422/4	4	Fan brackets to fan	
5	Ball Nut M8x1.25 Hex 1.6	888420/10	4	Fan to radiator mounting - 20 100g	
6	Plan Nut M8	888774	8	4x Fan to radiator 4x DV radiator bracket	
7	Plan Nut M8	888774	8	Radiator bobbin	
8	Plan Nut 1.47	887414	1	Expansion tank bracket	
9	Plan Washer 10 Hex 1.25	888414	13	18 x DV Fan Bracket 4 x Fan Brackets 1 x Expansion tank bracket	
10	Plan Washer 10 Hex 1.25	888414	4	Radiator bobbin back	
11	Plan Washer 10 Hex 1.25	888414/10	4	Radiator bobbin front	

Drawings are for illustrative purposes only and are not to scale. Page 1 of 2

Pack <b>D</b>		<b>CATERHAM</b>		44	
		PACK NUMBER		QUANTITY	
<b>COOLING SIGMA</b>					
<i>This pack may include extra fasteners to cover different options</i>					
ITEM	BASIC DESCRIPTION	PART NUMBER	QTY	USED ON	ILLUSTRATION
12	Plan Washer 10 Hex 1.25	888414/10	1	Expansion tank bracket	
13	Spring Washer 10 Hex 1.25	888414/10	8	8 x Radiator bobbin 1 x Expansion tank	
14	Wash Clip 10 Hex	887420-40	6	2 x 18 where hoses connect fan 2 x 18 radiator hose 2 x 18 when radiator hose	
15	Wash Clip 10 Hex	887420-30	2	1 x Engine outlet to top 1 Engine 1 x Engine outlet to radiator	
16	Hose Clip 17-20mm	88716-25	18	8 x Heater hoses 16 x 16 hoses 1 x Expansion tank 4 x DV Pump 4 x DV Radiator	
17	Wash Clip 10 Hex	887420-30	6	Expansion tank small 1 piece	
18	Plan - Black 10 Hex 1.25	887414/10	12	Cooling fan	

Drawings are for illustrative purposes only and are not to scale. Page 1 of 2

x1

The coolant concentrate should be diluted 50/50 with water. It does not need to be exact!

**Anthony L**

## ...TO CONNECT THE HEATER

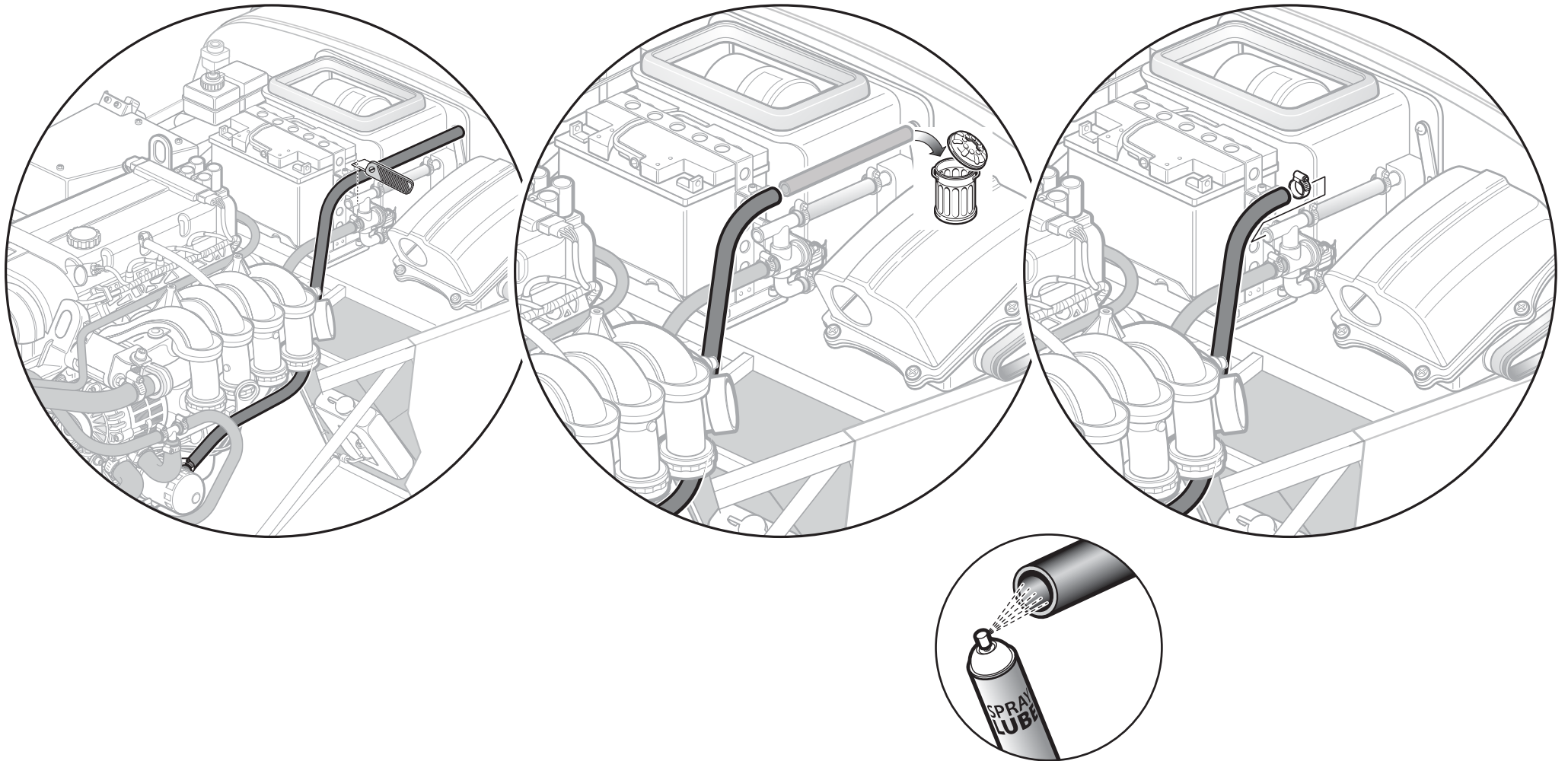

# WET / DRY SUMP THROTTLE CABLE

## PARTS

- 1** Throttle cable

## TOOLS

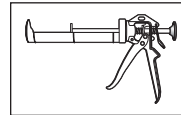
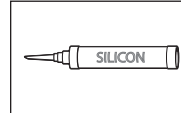
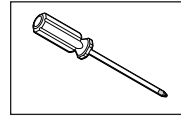

## FIXINGS

## TIPS

*The silicone goes in the top of the pedal to prevent the cable coming out.*

**Rich T**

*Cable tie the throttle cable to engine hoist eyelet.*

**Anthony L**

# WET / DRY SUMP THROTTLE CABLE

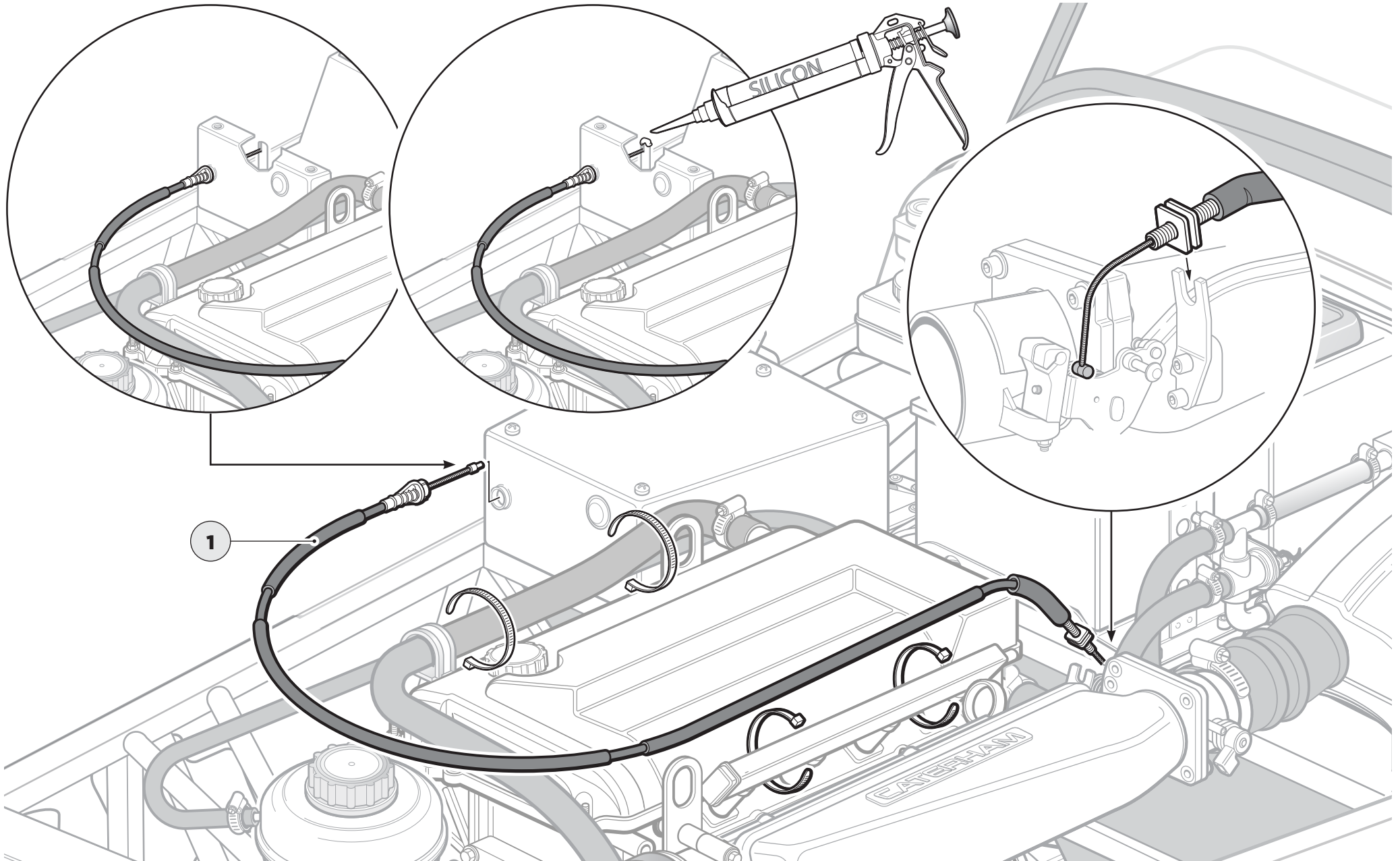

## FILL WITH COOLANT

---

### PARTS

Coolant concentrate

### TOOLS



### FIXINGS

### TIPS



Fill expansion bottle to max mark

# GIVING IT SOME DIRECTION

## PARTS

- 1 Lower steering column
- 2 Upper steering column
- 3 Steering column clamp
- 4 Steering column clamp plate
- 5 Grub screw
- 6 Steering column bush

## TOOLS

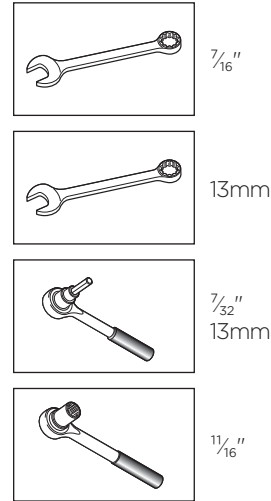

## FIXINGS

Pack B		CATERHAM		55	
		PACK NUMBER		MARCH 2011	
		RELEASED NOV-13			
STEERING DeDION CARS (METRIC)					
This pack may include extra fasteners to cover different options					
ITEM	BASIC DESCRIPTION	PART NUMBER	QTY	USED ON	ILLUSTRATION
1	BA Rack clamp 100 x 170 1/2"	BMX4070	4	Rack clamps	
2	BB Rack 17 x 17	BF1443 1/2"	2	Column clamp	
3	BC Ball Nut x 40 (DIN 934)	BMX440	2	Column to rack universal joint	
4	BD Nylon Nut 17" (self locking)	NF1112	1	Steering wheel boss	
5	BE Plain Nut 17"	NF1112	2	Track rod lock out	
6	BF Plain Nut 17" (self locking)	NF1112	1	Column clamp grub screw bracket	
7	BG Nyloc Nut M8	NF1119	2	Column to rack universal joint	
8	BH Nylon Nut M8	NF1119	4	Steering rack clamps	
9	BJ Plain Washer 16" x 16" (DIN 934)	WF1112	1	Steering wheel boss	
10	BA Plain Washer 17" (self locking)	WF1114	6	Rack clamps and column clamp	
11	BB Spring Washer 17" (self locking)	WF1114	2	Column clamp	

x2  
x1  
x2  
x1

## TIPS

Check clearance between steering column & Aux belt tensioner once engine is installed. If necessary, rotate steering rack.

**Dan P**

Put the clamp in the middle of column with the grooved face of the clamp plate ④ against the column.

**Jamie A**

Steering rack to be rotated to fit column – don't forget to tighten rack brackets!

**Harrison P**

Grease the steering bushes.

**Lee A**

Fit the clamp bolts first, then grub screw & finish with the locking nut.

**Tiago O**

# GIVING IT SOME DIRECTION

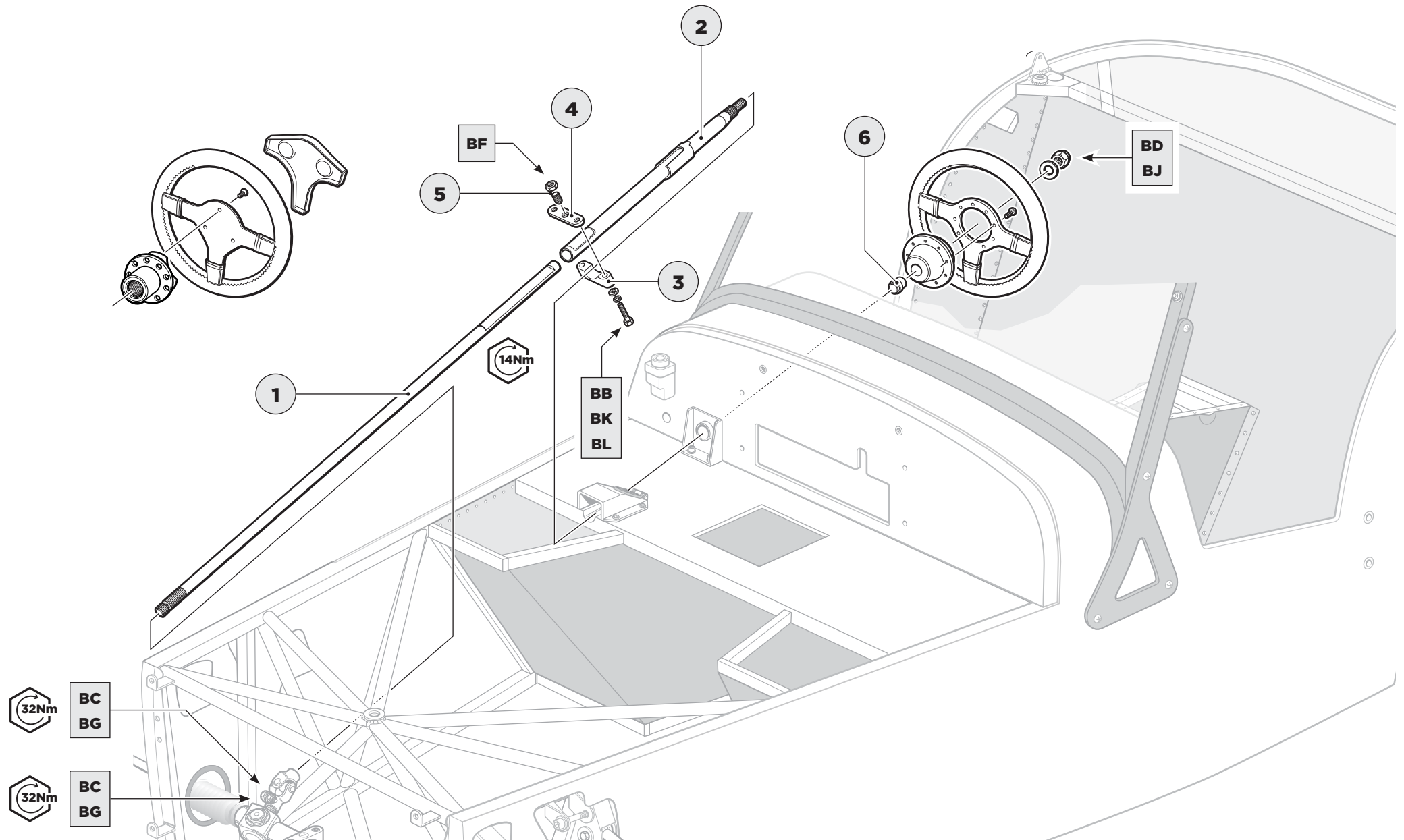

# THIS IS EXHAUSTING

## PARTS

- 1 Exhaust manifold gasket
- 2 Exhaust primary pipes
- 3 Cat / Collector
- 4 Exhaust collector springs

## TOOLS

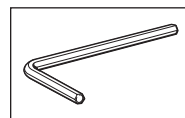

8mm

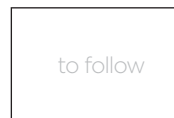

to follow

Extension

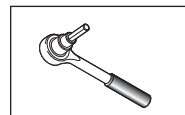

8mm

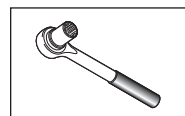

17mm  
(270 & 310 only)

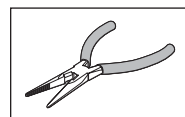

## FIXINGS

Fixings are supplied loosely attached to the engine in place

## TIPS

Use cable ties to compress exhaust spring.

Mick F

A pair of pliers are best to help hook over.

James A

Put masking tape round exhaust hole to prevent scratches.

Chris B

Work out which primary pipe goes where, individually then put all four in plane, starting with the front one & working back. Take care with the hooks on your paintwork.

Chris N

# THIS IS EXHAUSTING

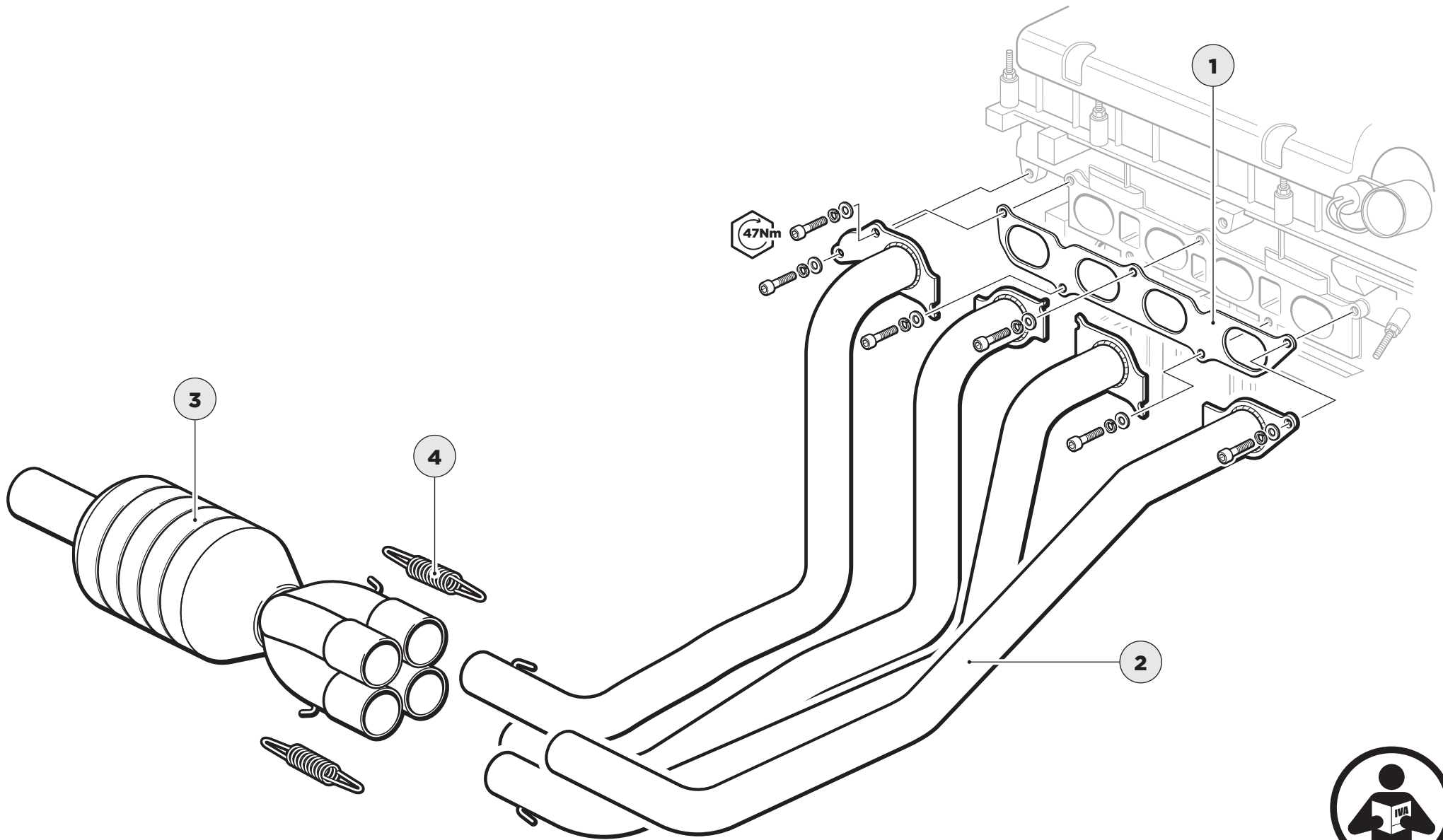

# FITTING THE HANDBRAKE

## PARTS

- 1 Handbrake assembly
- 2 Handbrake pulley
- 3 Handbrake clevis
- 4 Pulley clevis pin
- 5 Handbrake clevis pin
- 6 Handbrake cable

## TOOLS

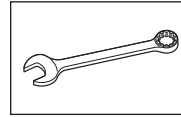

13mm (x2)

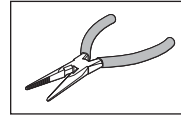

## FIXINGS

### Miscellaneous pack

- Setscrew 8 (x25)
- Washer M8
- Washer M6

## TIPS

Remember to put a loop in inner cable around pulley.

**Grant P**

Cable tie adjuster end of cable to diff.

**Dan D**

Use pliers to bend the legs of the split-pins once in place, which then holds them loosely in the clevis pins.

**Chris B**

Handbrake wire connector goes to top of terminal & ties up.

**Jamie A**

After plugging in connector, cable tie and secure any excess wiring.

**Dan P**

# FITTING THE HANDBRAKE

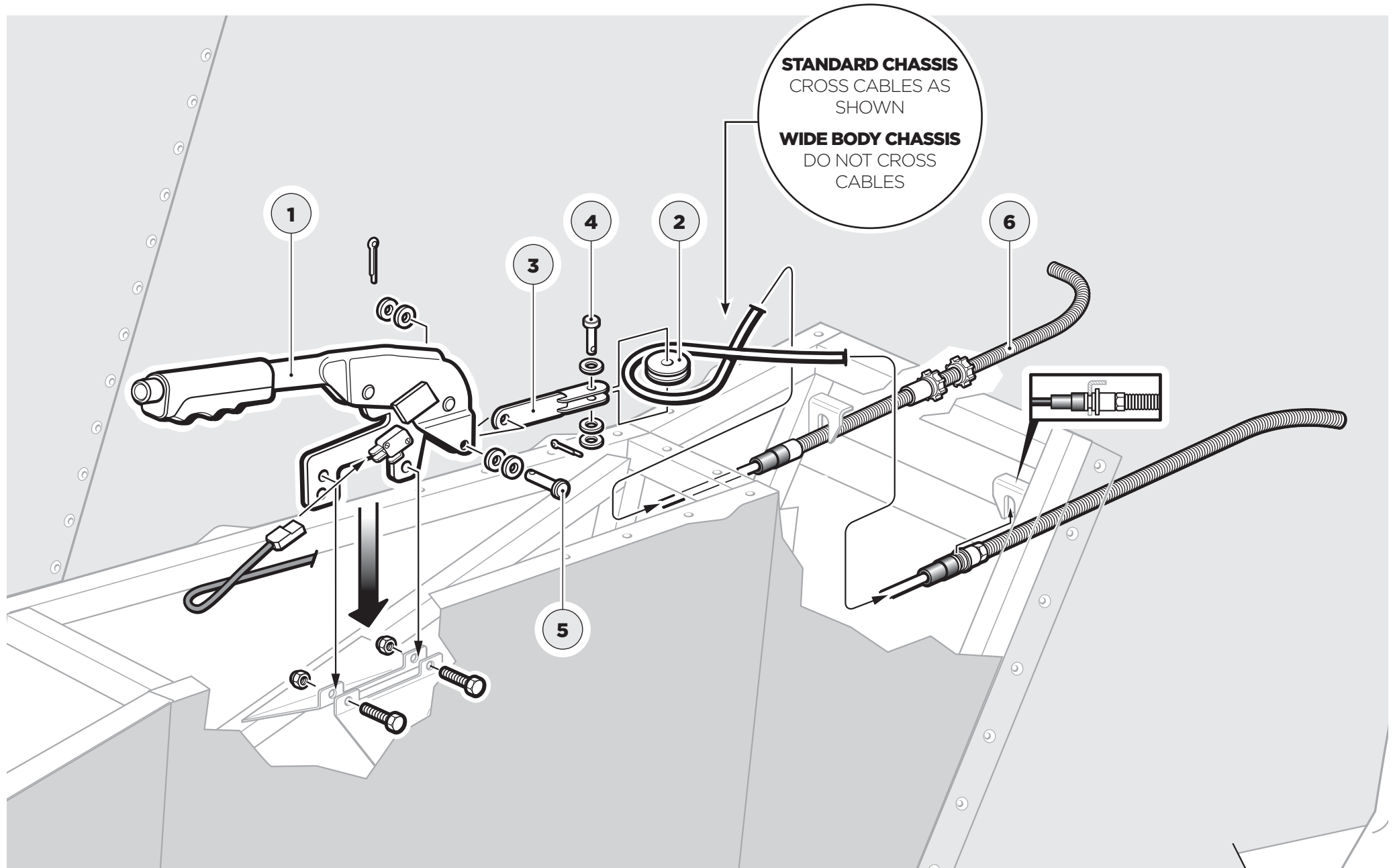

# SLIDE IN THE PROPSHAFT

## PARTS

- 1 Propshaft

## TOOLS



## FIXINGS

## TIPS

Line the splines in the propshaft to the gearbox.

**Anthony L**

Grease prop if necessary, it will have a grease nipple.

**John S**

## SLIDE IN THE PROPSHAFT

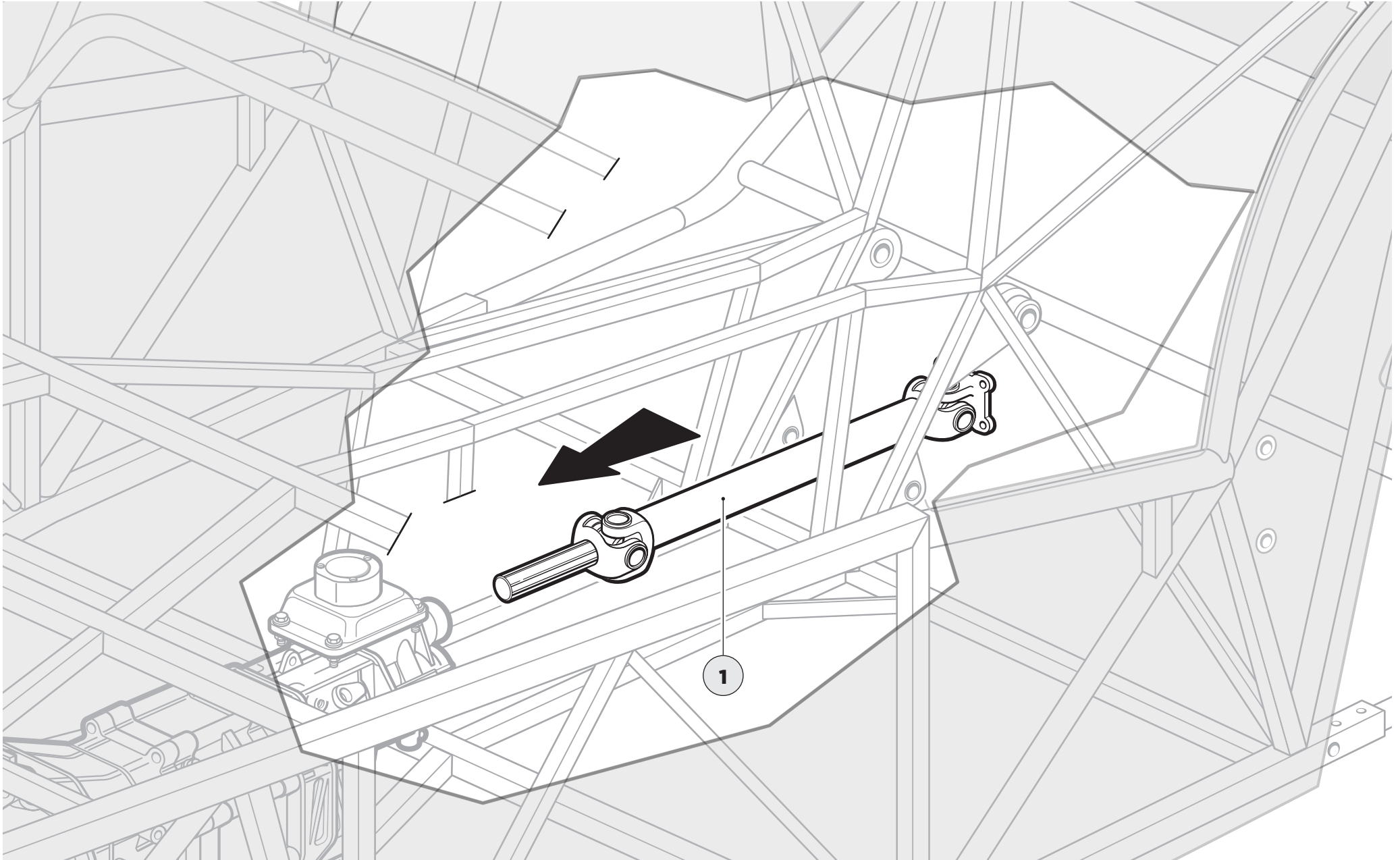

# HEAVY STUFF: FITTING THE DIFF

## PARTS

**1** Differential

## TOOLS

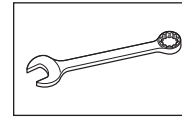

19mm

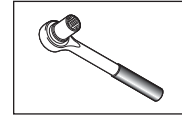

19mm

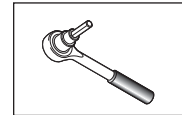

10mm  
8mm

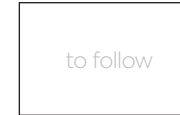
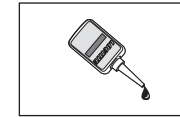

Extension

## FIXINGS

ITEM	BASIC DESCRIPTION	PART NUMBER	QTY	USED ON	ILLUSTRATION
1	Bolt 1/2" x 11" LHF	BP12X11	1	Upper diff mounting bolt	
2	Caphead Bolt M12 x 55 Grade 10.9	BMCH12X55	2	Lower diff mounting bolt	
3	Bolt M10 x 35 Grade 10.9	BM10X35	4	Rear hub through axle to front DeDion	
4	Bolt M10 x 35 Grade 10.9	BM10X35	8	3 x 4 Front hub through ear x 4 Caliper carrier bolts	
5	Bolt M10 x 35 Grade 10.9	BM10X35	4	Through rear of axle into Reinforced DeDion tubes	
6	Caphead Bolt M12 x 25 Grade 12.9	BMCH12X25	4	Propshaft bolts	
7	Caphead Bolt M12 x 25 Grade 12.9	BMCH12X25	2	Diff cage	
8	Half Nuts 1/2" Type	NFY1/2	1	Upper diff bolt	
9	Hex Nut M10	NM10	8	Hub through axle to DeDion	
10	1/2" Hex Nut M8	NM1/2	4	Rear axle roll bar brackets	
11	Plain washer 1/2" x 3/4"	W1/2X3/4	2	Brake pipe	

x1

x2

x4

x1

ITEM	BASIC DESCRIPTION	PART NUMBER	QTY	USED ON	ILLUSTRATION
12	Plain washer 1/2" x 3/4" Thin	W1/2X3/4	16	Flats behind diff shells	
13	Plain washer 1/2" x 3/4" Thin	W1/2X3/4	8	Free play on diff	
14	Plain washer 1/2" x 3/4" Thin	W1/2X3/4	16	Diff shim washers	
15	Washer M12	W12X12	16	Rear DeDion Carrier Carrier Hub	
16	Spring Washer M10	WS10X10	16	Rear DeDion Tube Carrier Carrier	
17	Softener washer M12	WS12	4	Behind bolt heads on diff	
18	Reinforced washer 1/2"	WR1/2	1	Braked brake hose	
19	Rear 1/2" x 5.51"	1/2-5.51	5	P-clips on DeDion for brake pipe	
20	P-Clip	PK1	5	Brake pipe on DeDion	

\* Use as required for spacing

## TIPS

Start at bottom right with spanner & work your way around.

Chris B

Make sure propshaft is in first!

Harry P

Lower diff bolts may require more than one washer – try to keep them even.

Tiago O

# HEAVY STUFF: FITTING THE DIFF

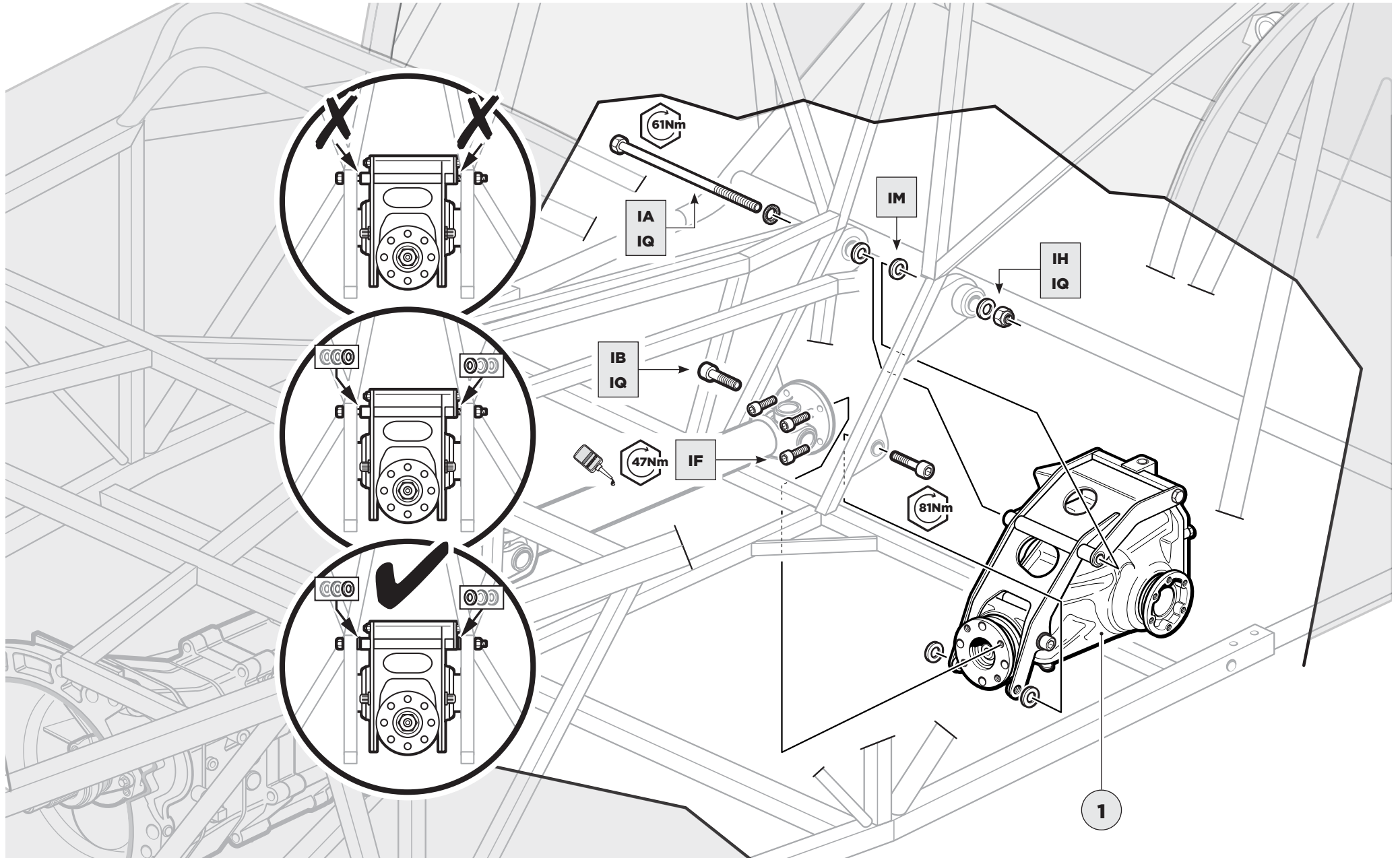

## FILL THE DIFFERENTIAL WITH OIL

---

P A R T S

T O O L S

Differential oil

F I X I N G S

T I P S



Differential = 0.8L

# PREPARING THE DEDION TUBE

## PARTS

- 1 DeDion tube
- 2 LHS brake pipe
- 3 RHS brake pipe
- 4 3 way union
- 5 Brake hose

## TOOLS

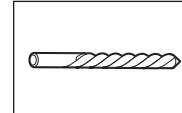
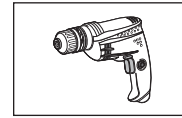

1/8"

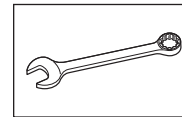
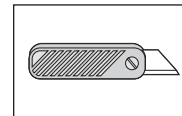

11mm  
13mm  
14mm

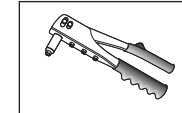
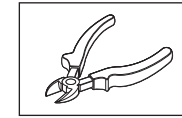

## FIXINGS

Pack <b>H</b>		<b>CATERHAM</b>		53
				PACK NUMBER
				30R01TD
REAR SUSPENSION DEDION METRIC				
This pack may include extra fasteners to cover different options				
ITEM	BASIC DESCRIPTION	PART NUMBER	QTY	USED ON
1	Ball Joint LHS (Caster 10.0)	SM214100	2	A-frame front mountings
2	Capstan Bolt M10 x 6.0	SM211000	2	Front radius arm (through cockpit)
3	Nut 12.7 x 2.2 (2.0) (Caster 10.0)	SM1202102	4	x 2 Lower Race Damper x 2 Rear Radius Arm
4	Ball Mt X-60 (Caster 10.0)	SM1000	4	Rear Axel Roll Bar Mounting Blocks
5	Ball Mt X-2 (2.0) (Caster 10.0)	SM1202104	1	A-frame to DeDion
6	Roller Race 12.7 (2.0)	SM1101102	3	x 2 Rear Radius Arm 1 A-frame to DeDion
7	Nut Mt M12	SM1101102	2	A-frame front mounting
8	Nut Mt M10	SM1101102	2	Front radius arm (through cockpit)
9	Nut Mt M10	SM1101102	2	Rear Axel Roll Bar Drop Link
10	Nut Mt M10	SM1101102	4	Rear Axel Roll Bar Mounting Blocks
11	HK Metric Nut 14"	SM1101104	1	3-way union on DeDion tube

Drawings are for illustrative purposes only and are not to scale. Page 1 of 2

x1

Pack <b>I</b>		<b>CATERHAM</b>		44
				PACK NUMBER
				30Z1067B
AXLE DEDION METRIC				
This pack may include extra fasteners to cover different options				
ITEM	BASIC DESCRIPTION	PART NUMBER	QTY	USED ON
1	IA Upper 12.7 x 1.75 (2.0)	SM1120111	1	Upper roll mounting bush
2	IB Capstan Bolt M12 x 6.0 (Caster 10.0)	SM2110110	2	Lower roll mounting bush
3	SM1101100	SM100000	4	Rear roll through ear to front DeDion
4	SM1101100	SM100000	8	x 4 Front roll through ear x 4 Capstan capstan bush
5	SM1101100	SM100000	4	Through rear of ear into threaded DeDion tubes
6	Capstan Bolt M10 x 2.0 (Caster 10.0)	SM2110110	4	Frontroll bush
7	Capstan Bolt M10 x 2.0 (Caster 8.0)	SM2110110	2	Off rags
8	Roller Race 12.7 (2.0) (Caster 10.0)	SM1101102	1	Upper roll bush
9	Nut Mt M10	SM1101102	8	Hub through ear to DeDion
10	12.7 (2.0) Nut Mt M10	SM1101102	4	Rear axle roll bar dropout
11	HK Plain washer 38" x 7.87"	SM1101102	2	Brake pipe

Drawings are for illustrative purposes only and are not to scale. Page 1 of 2

x2

Pack <b>I</b>		<b>CATERHAM</b>		44
				PACK NUMBER
				30Z1067B
AXLE DEDION METRIC				
This pack may include extra fasteners to cover different options				
ITEM	BASIC DESCRIPTION	PART NUMBER	QTY	USED ON
12	SL Shim washers 12.7 x 7.87"	SM1120110	10	Front timing roll bush
13	SA Thin washer 12.7 x 9.84"	SM1101102	8	Thin plate on off
14	Thin washer 12.7 x 9.84" (2.0) (Caster 10.0)	SM1101102	14	Off shim washers
15	Washer M10	SM1101102	10	Rear DeDion Caliper Carrier Hub
16	Spring Washer M10	SM1101102	10	Rear DeDion Tube Caliper Carrier
17	Spring Washer M10	SM1101102	4	Behind ball bushes on off
18	IR Shaperoll washer 38"	WES38	1	Branded brake hose
19	IB Roll 12.7 x 9.84"	1661-0414	3	P-clips on DeDion for brake pipe
20	IT P-clip	NX1	5	Brake pipe on DeDion

Drawings are for illustrative purposes only and are not to scale. Page 2 of 2

x1  
x5  
x5

Brake pipe washers and nuts are included with the hose

## TIPS

The upper brake hose fittings will become self explanatory on the rear damper installation page.

John K

Tighten the braided pipe 5 into the union before nipping up the locknut.

Chris N



## AND FITTING IT IN PLACE

---

P A R T S

T O O L S

F I X I N G S

T I P S

## AND FITTING IT IN PLACE

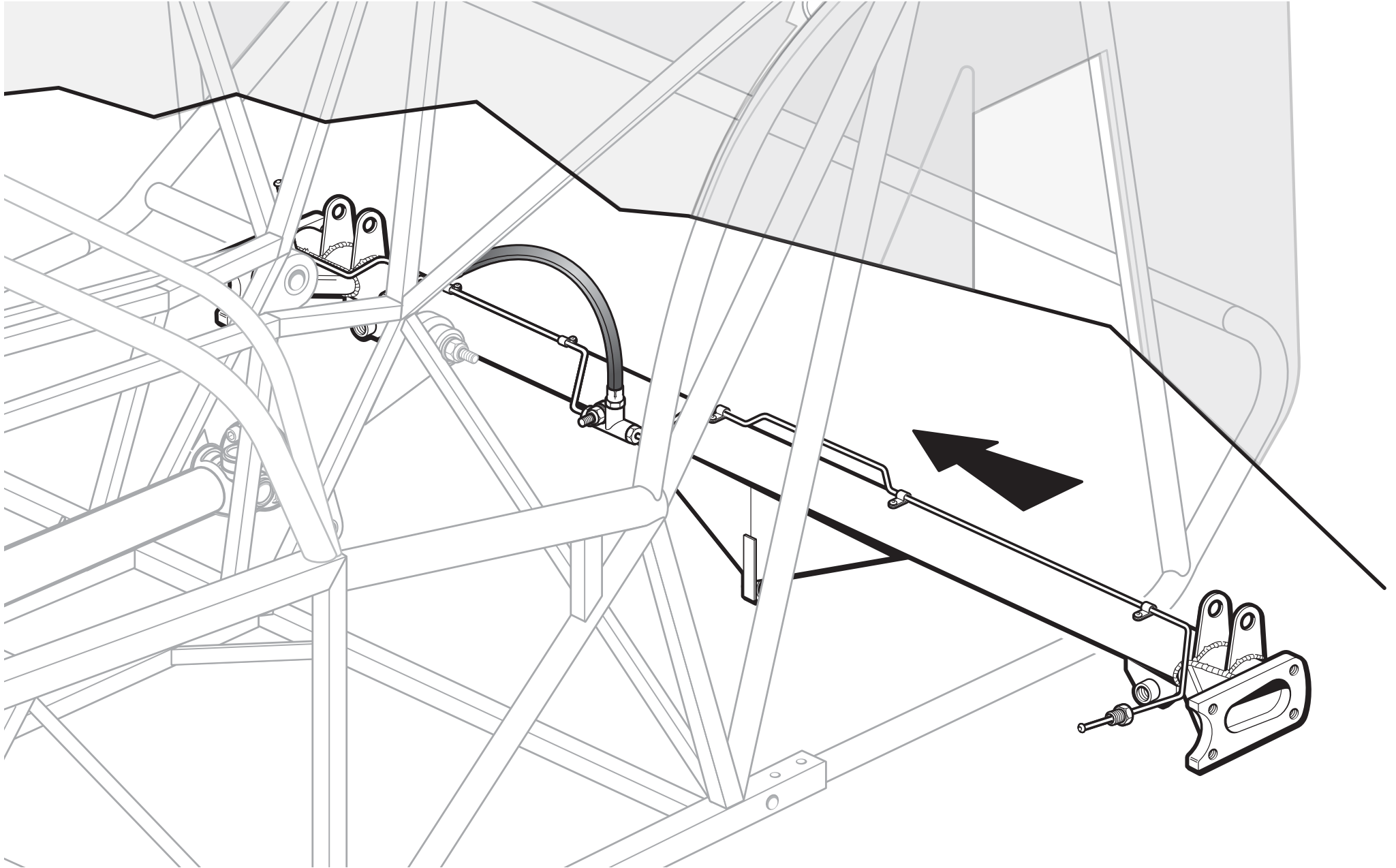

# ATTACHING THE REAR DAMPERS

## PARTS

- 1** Rear damper assembly
- 2** Rear damper sleeve

## TOOLS

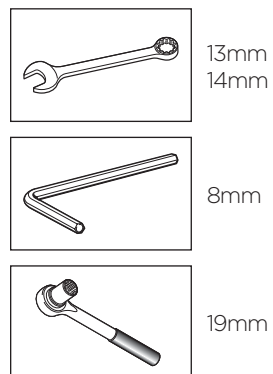

## FIXINGS

Pack <b>H</b>		CATERHAM		53	
		PART NUMBER		30R011D	
REAR SUSPENSION DEDION METRIC					
This pack may include extra fasteners to cover different options					
ITEM	BASIC DESCRIPTION	PART NUMBER	QTY	USED ON	ILLUSTRATION
1	Ball Joint L/R (Gask 10.3)	BM214100	2	A-frame front mountings	
2	Coilover Rod (10.3)	BM211000	2	Front radius arm (through cockpit)	
3	Bar 10" x 2.10" (Gask 10.3)	BF1202.10	4	x 2 Lower Rear Damper x 2 Rear Radius Arm	
4	Roll Over Bar (10.3)	BM0000	4	Rear Anti Roll Bar Mounting Blocks	
5	Roll Over Bar (10.3) (Gask 10.3)	BF1202.10	1	A-frame to DeClic	
6	Roll Over Bar (10.3) (Gask 10.3)	BF1202.10	3	x 2 Rear Radius Arm x 1 A-frame to DeClic	
7	Rear Nut M12	NM0110	2	A-frame front mountings	
8	Rear Nut M12	NM0110	2	Front radius arm (through cockpit)	
9	Rear Nut M12	NM0110	2	Rear Anti Roll Bar Drop Link	
10	Rear Nut M12	NM0110	4	Rear Anti Roll Bar Mounting Blocks	
11	Rear Nut M12	NM0110	1	x 1 Nut union on DeClic tube	

x2

Pack <b>H</b>		CATERHAM		53	
		PART NUMBER		30R011D	
REAR SUSPENSION DEDION METRIC					
This pack may include extra fasteners to cover different options					
ITEM	BASIC DESCRIPTION	PART NUMBER	QTY	USED ON	ILLUSTRATION
12	Washer	7620	10	Differential isolation	
13	Plain Washer 10" (Chamfered)	WP10.2	20	x 2 Lower Damper x 10 A-frame washers x 6 Radius Arm	
14	Plain Washer 10" x 10"	WP10X10.2	2	Front Radius Arm	
15	Plain Washer 10"	WP10.2	4	Rear Anti Roll Bar Mounting Block	
16	Shim Washer M12	3021000A	2	Lower Damper	

x4

x2

## TIPS

Although we show the fitting of the dampers here as part of the rear suspension, it is better to leave this step until you've fitted the roll over bar much later in the process.

**Jamie A**

# ATTACHING THE REAR DAMPERS

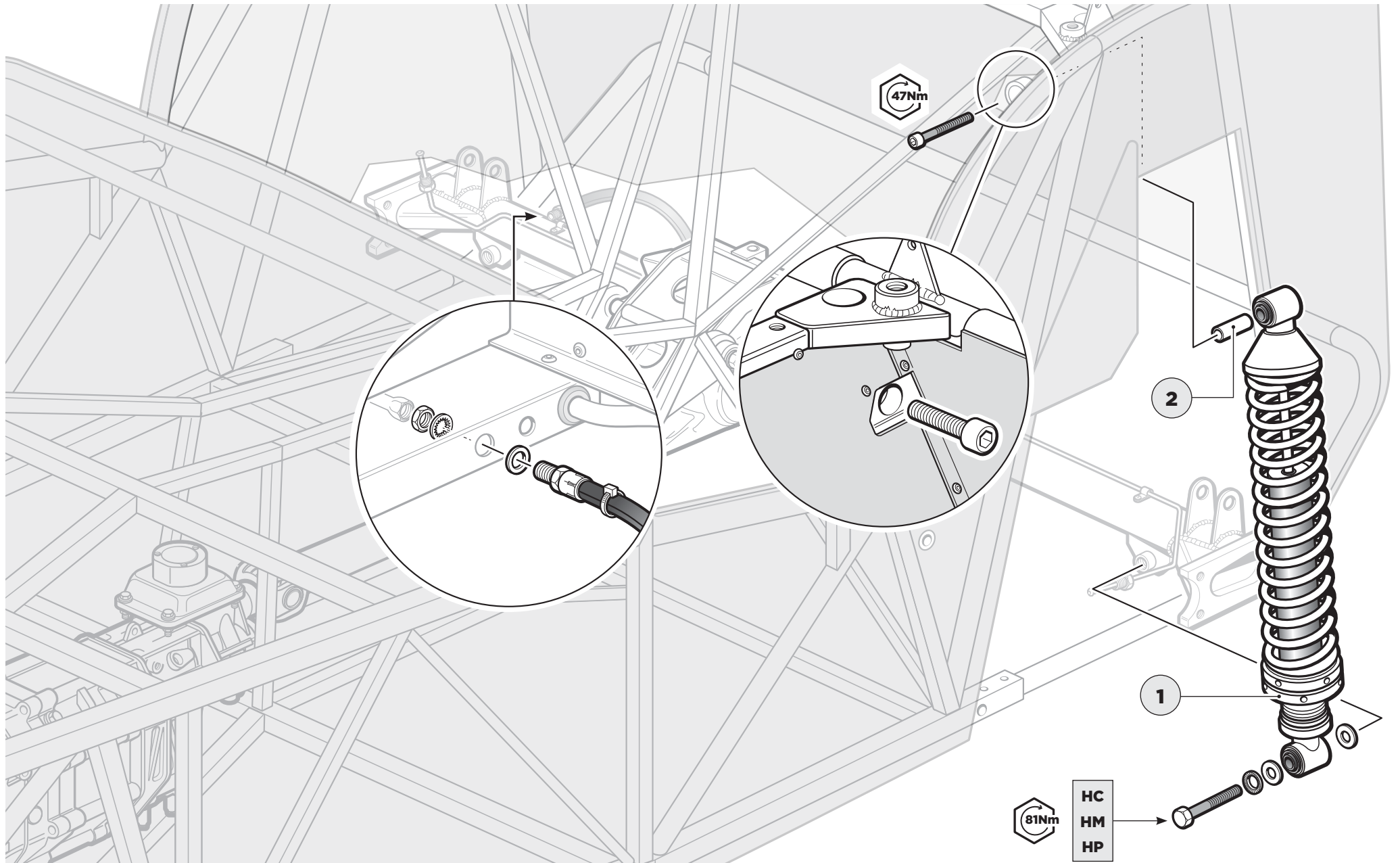

# THEN THE RADIUS ARM

## PARTS

**1** Radius arm

## TOOLS

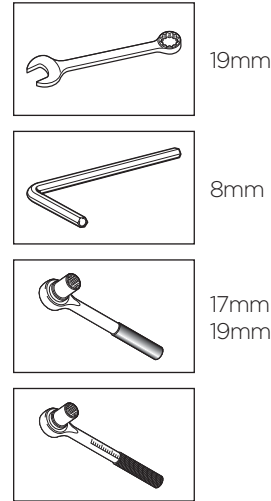

## FIXINGS

Pack <b>H</b>		CATERHAM		53	
		PACK NUMBER		30R011D	
REAR SUSPENSION DE Dion METRIC					
This pack may include extra fasteners to cover different options					
ITEM	BASIC DESCRIPTION	PART NUMBER	QTY	USED ON	ILLUSTRATION
1	Ball Joint 1.5" (38mm)	BM12110	2	A-frame front mountings	
2	Caphead Bolt M10 x 65	BMCH10505	2	Front radius arm (through cockpit)	
3	Bolt 1/2" x 2.125" Grade 10.9	BF12X2.125	4	x 2 Lower Rear Damper x 2 Rear Radius Arm	
4	Roller Nut M10 x 40 Grade 10.9	BNM1040	4	Rear Anti Roll Bar Mounting Blocks	
5	Ball Joint 1.5" x 2.125" (38mm)	BM12X2.125	1	A-frame to DeDion	
6	Half Nuts 1/2" (38mm)	NFY1102	3	x 2 Rear Radius Arm x 1 A-frame to DeDion	
7	Roller Nut M10	BNM1102	2	A-frame front mountings	
8	Nylon Nut M10	NBM1110	2	Front radius arm (through cockpit)	
9	Roller Nut M10	BNM1102	2	Rear Anti Roll Bar Drop Link	
10	Roller Nut M10	BNM1102	4	Rear Anti Roll Bar Mounting Blocks	
11	Nylon Nut M10	NBM1110	1	1" Nylon Union on DeDion tube	

x2  
x2  
x2  
x2

Pack <b>H</b>		CATERHAM		53	
		PACK NUMBER		30R011D	
REAR SUSPENSION DE Dion METRIC					
This pack may include extra fasteners to cover different options					
ITEM	BASIC DESCRIPTION	PART NUMBER	QTY	USED ON	ILLUSTRATION
12	Washer	W020	10	Differential Isolation	
13	Plain Washer 1/2" (12.7mm)	WP1102	20	x 2 Lower Damper x 10 A-frame washers x 4 Radius Arm	
14	Plain Washer 3/8" x 1/2"	WP13X1/2	2	Front Radius Arm	
15	Plain Washer 1/2"	WP1102	4	Rear Anti Roll Bar Mounting Block	
16	Conical Washer M10	SW1010A	2	Lower Damper	

x4  
x2

## TIPS

Before torquing up these bolts, reposition the axle stands to under the DeDion tube (to hold up the suspension). Make sure front has two axle stands so it is steady when jacking up the rear!

**Mick F**

## THEN THE RADIUS ARM

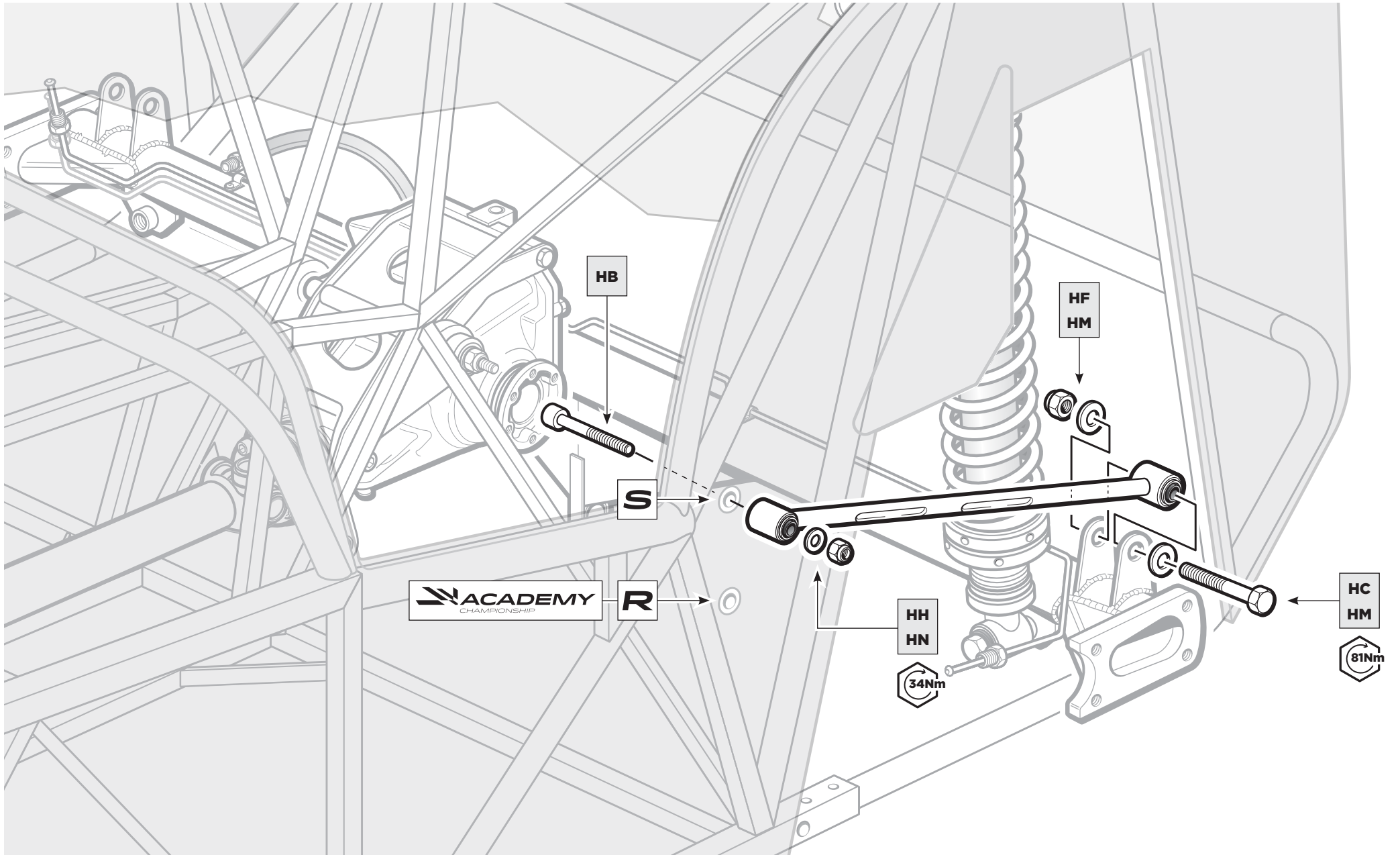

# AND NOW THE (CAREFULLY SPACED) A-FRAME

## PARTS

- 1 A-frame
- 2 White nylon anti-squeak washers

## TOOLS

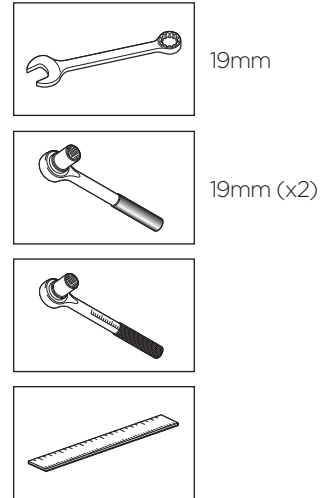

## FIXINGS

Pack H		CATERHAM		53	
		PACK NUMBER		30R01TD	
REAR SUSPENSION DEDION METRIC					
This pack may include extra fasteners to cover different options					
ITEM	BASIC DESCRIPTION	PART NUMBER	QTY	USED ON	ILLUSTRATION
1	Half 1/2" x 1/2" Grade 10.9	BM12X100	2	A-frame front mountings	
2	Cuphead Bolt 1/2" x 1/2"	BM12X100	2	Front radius arm through coilover	
3	Bolt 1/2" x 2 1/2" Grade 10.9	BF12X2152	4	x 2 Lower Rear Champs x 2 Rear Radius Arm	
4	Roller Nut x 20 Grade 10.9	AN20x20	4	Rear Anti Roll Bar Mounting Blocks	
5	Half 1/2" x 2 3/4" Grade 10.9	BF12X234	1	A-frame to DeDion	
6	Half Nylon 1/2" Nut	NFY1/2	3	x 2 Rear Radius Arm x 1 A-frame to DeDion	
7	Nylon Nut M12	NMY12	2	A-frame front mounts	
8	Nylon Nut 1/2"	NMY1/2	2	Front radius arm through coilover	
9	Nylon Nut 1/2"	NMY1/2	2	Rear Anti Roll Bar Drop Link	
10	Nylon Nut 1/2"	NMY1/2	4	Rear Anti Roll Bar Mounting Blocks	
11	Nylon Nut 1/2"	NMY1/2	1	x 1 Nylon nut on DeDion tube	

Drawings are for illustrative purposes only and are not to scale. Page 1 of 2

x2

x1

x1

x2

Pack H		CATERHAM		53	
		PACK NUMBER		30R01TD	
REAR SUSPENSION DEDION METRIC					
This pack may include extra fasteners to cover different options					
ITEM	BASIC DESCRIPTION	PART NUMBER	QTY	USED ON	ILLUSTRATION
12	Washer	7622	10	Differential Isolation	
13	Plain Washer 1/2" Chamfered	WPH1/2	20	x 2 Lower Champs x 10 A-frame washers x 6 Radius Arm	
14	Plain Washer 1/2" x 1/2"	WPH1/2x1/2	2	Front Radius Arm	
15	Plain Washer 1/2"	WPH1/2	4	Rear Anti Roll Bar Mounting Block	
16	Conical Washer M12	CS12036A	2	Lower Champs	

Drawings are for illustrative purposes only and are not to scale. Page 2 of 2

\*

\* Use as required for spacing

## TIPS

Make sure the DeDion tube is equal on both sides.

**Tiago O**

Use as many HM washers as required to space A-frame.

**John K**

The A-frame has a 'way up'. The arms should be offset downwards in relation to the front bushes.

**Chris N**

Take care to use the correct nuts as there is a mixture of metric and imperial here.

**Lee A**

Torque up as before on axle stands.

**Rich T**

## AND NOW THE (CAREFULLY SPACED) A-FRAME

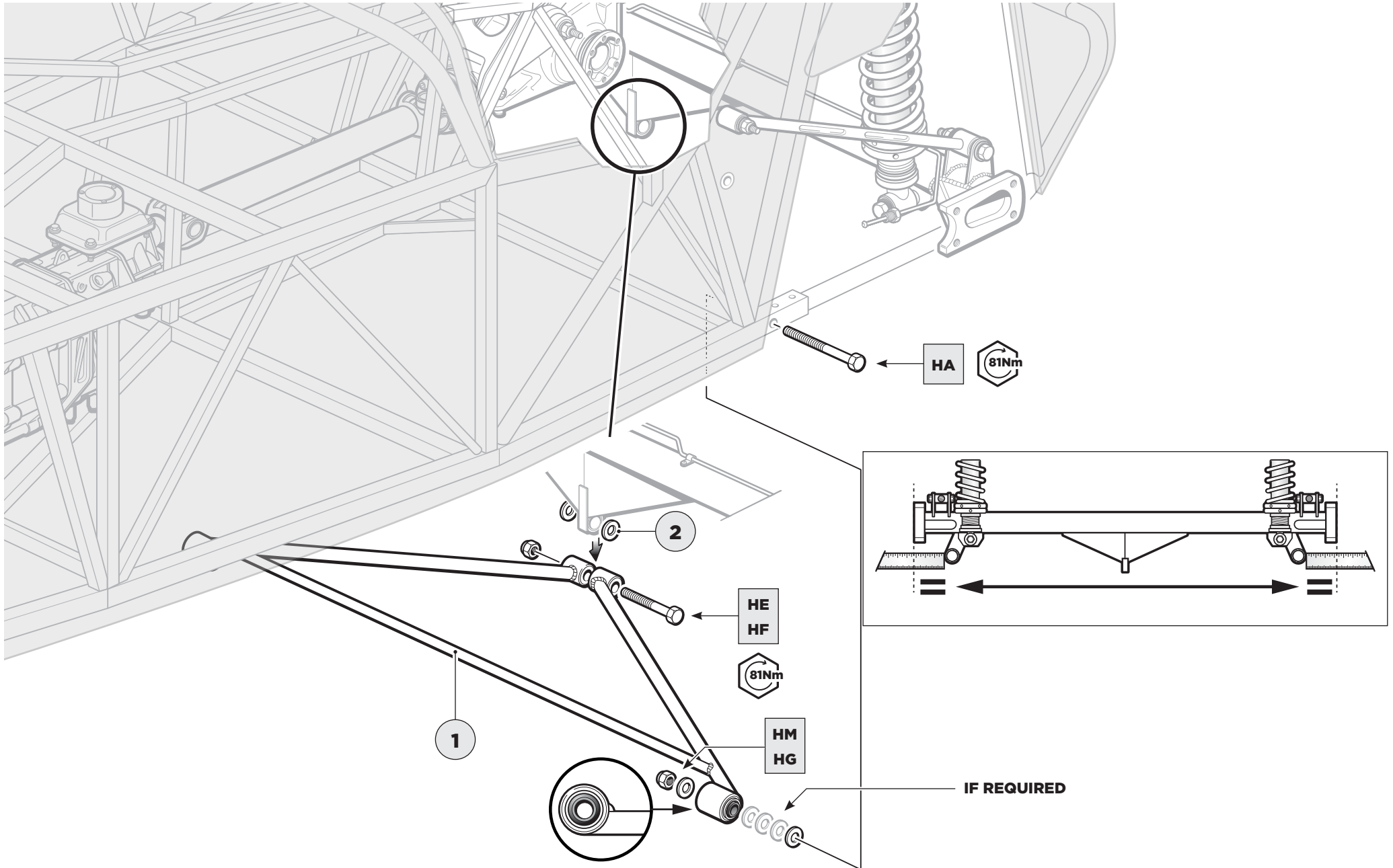

# IF YOU HAVE THE OPTIONAL REAR ANTI-ROLL BAR, IT GOES ON LIKE THIS

## PARTS

- 1 Rear anti roll bar
- 2 Anti roll bar rubber
- 3 Rear anti roll bar clamp

## TOOLS

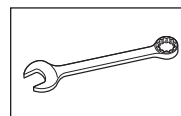
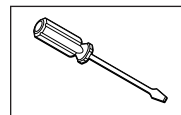
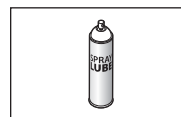

10mm



10mm

## FIXINGS

Pack <b>H</b>		CATERHAM		53	
		PART NUMBER		30R011D	
REAR SUSPENSION DEDION METRIC					
This pack may include extra fasteners to cover different options					
ITEM	BASIC DESCRIPTION	PART NUMBER	QTY	USED ON	ILLUSTRATION
1	Roll Over 2.0" (50.8mm) Clutch 10.5"	BM124100	2	A-frame front mountings	
2	Coilover Fork 10" x 10"	BM121100	2	Front radius arm (through coilover)	
3	Roll Over 2.0" (50.8mm) Clutch 10.5"	BM124102	4	X 2 Lower Rear Damper X 2 Rear Radius Arm	
4	Bolt M8 x 40 Clutch 10.5"	BM0000	4	Rear Anti Roll Bar Mounting Blocks	
5	Roll Over 2.0" (50.8mm) Clutch 10.5"	BM124104	1	A-frame to DeClicon	
6	Roll Over 10" (254mm)	BM121102	3	X 2 Rear Radius Arm X 1 A-frame to DeClicon	
7	Rover Nut M12	BM121101	2	A-frame front mountings	
8	Rover Nut M10	BM121103	2	Front radius arm (through coilover)	
9	Roll Over 10" (254mm)	BM121100	2	Rear Anti Roll Bar Drop Link	
10	Nylon Nut M8	BM121105	4	Rear Anti Roll Bar Mounting Blocks	
11	Rover Nut M10	BM121104	1	X 1 Nylon nut on DeClicon tube	

x4

x4

Pack <b>H</b>		CATERHAM		53	
		PART NUMBER		30R011D	
REAR SUSPENSION DEDION METRIC					
This pack may include extra fasteners to cover different options					
ITEM	BASIC DESCRIPTION	PART NUMBER	QTY	USED ON	ILLUSTRATION
12	Washer	W0000	10	Differential isolation	
13	Plain Washer 10" (254mm)	W10000	20	X 2 Lower Damper X 10 A-frame washers X 4 Radius Arm	
14	Roll Washer 30" x 30"	W1000000	2	Front Radius Arm	
15	Plain Washer M8	W10000	4	Rear Anti Roll Bar Mounting Block	
16	Lower Damper M10	SD120000	2	Lower Damper	

x8

## TIPS

Be careful not to slip with the screwdriver!

John S

## IF YOU HAVE THE OPTIONAL REAR ANTI-ROLL BAR, IT GOES ON LIKE THIS

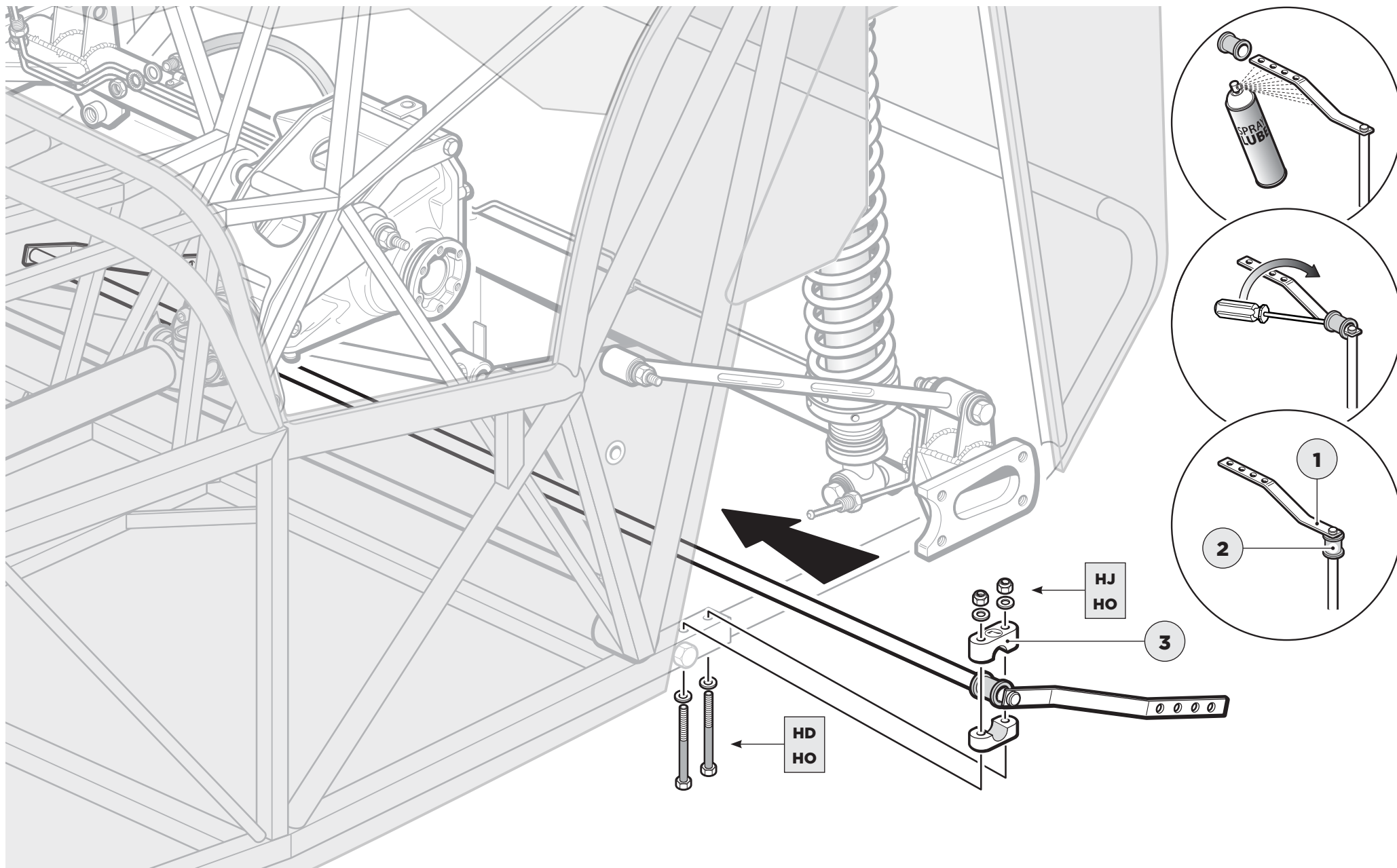

## INSERT THE DRIVESHAFTS

---

### PARTS

- 1 Driveshaft
- 2 Driveshaft nut

### TOOLS

### FIXINGS

### TIPS

*Driveshafts are handed, and so are the nuts, the left hand nut tightens anti-clockwise.*

**James A**

## INSERT THE DRIVESHAFTS

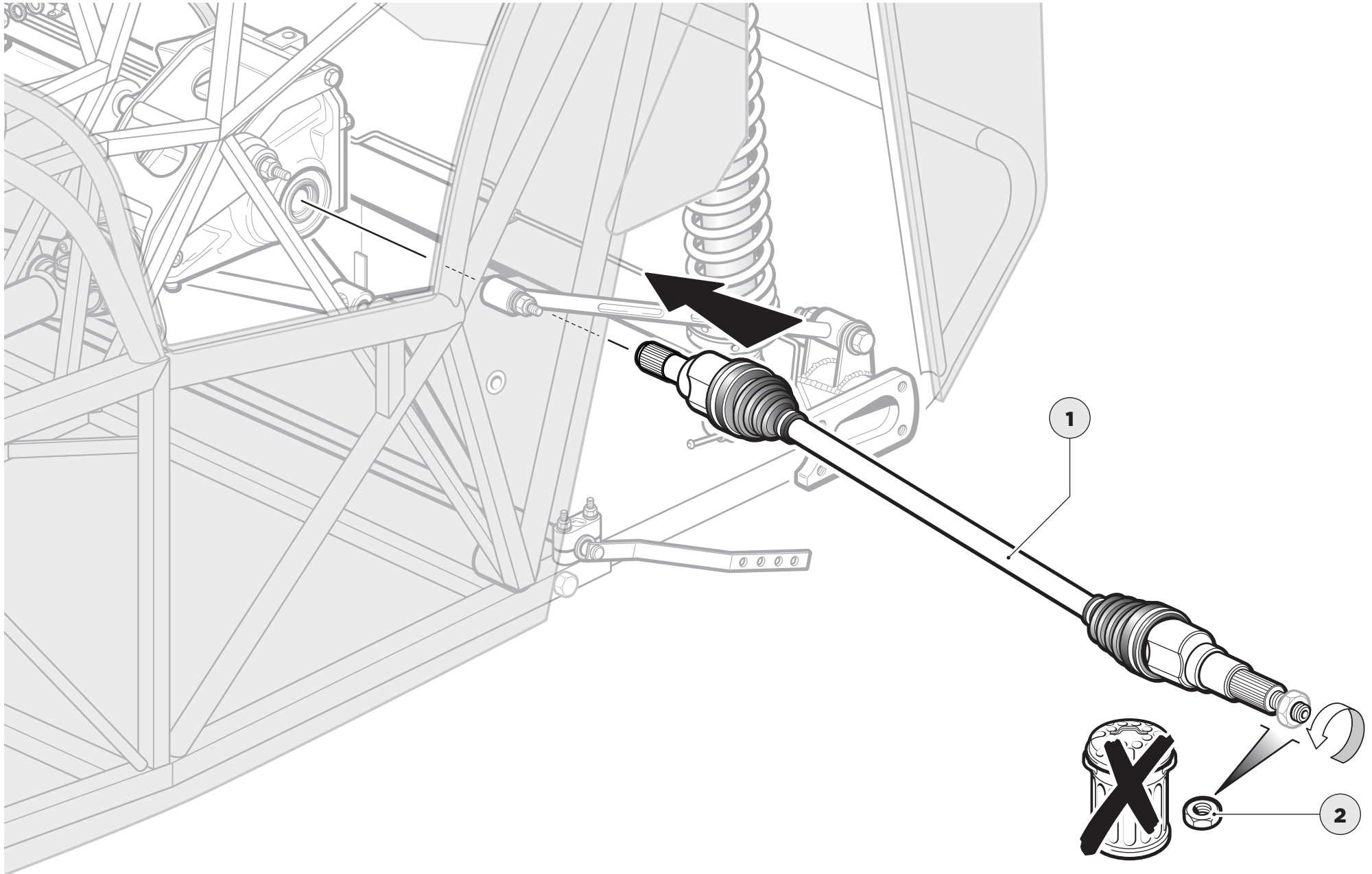

# FITTING THE REAR HUB

## PARTS

- 1** Rear brake disc / flange assembly
- 2** Rear hub
- 3** DeDion ear
- 4** Anti roll bar bracket
- 5** Anti roll bar drop link
- 6** Brake calliper
- 7** Brake calliper mount
- 8** Brake pads
- 9** Driveshaft nut
- 10** Driveshaft washer

## TOOLS

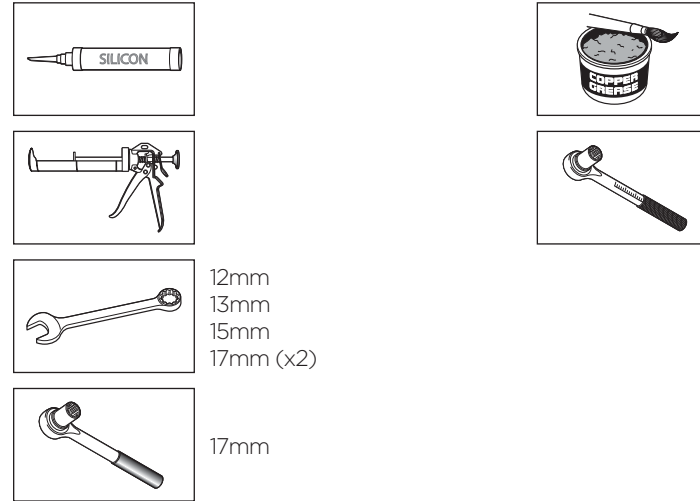

## FIXINGS

Pack 1		CATERHAM		44	
AXLE DEDION METRIC					
This pack may include extra fasteners to cover different options					
ITEM	BASIC DESCRIPTION	PART NUMBER	QTY	USED ON	ILLUSTRATION
1	Hub 12" x 17" 40	BM12A11	1	Upper off mounting bolt	
2	Upper off mounting bolt 12" x 17" 40	BM12A11	2	Lower off mounting bolt	
3	IC Bolt M10 x 55 Grade 10.9	BM10A85	4	Rear hub through ear to front DeDion	
4	ID Bolt M10 x 55 Grade 10.9	BM10A35	8	x 4 Front hub through ear x 4 Caliper carrier bolts	
5	IE Bolt M10 x 40 Grade 10.9	BM10A40	4	Through rear of ear into threaded DeDion holes	
6	IF Caliper carrier bolt 12" x 17" 40	BM12A11	4	Proprietary bolts	
7	IG Caliper carrier bolt 12" x 17" 40	BM12A11	2	DR page	
8	IH Upper off bolt 12" x 17" 40	BM12A11	1	Upper off bolt	
9	II Nylon Nut M10	BM10A10	8	Hub through ear to DeDion	
10	IJ 1/2" Nylon Nut 180	BM10A18	4	Rear anti roll bar droplink	
11	IK Nylon washer 12" x 17"	BM12A11	2	Brake pads	

x4  
x8  
x4  
x8  
x4

Pack 1		CATERHAM		44	
AXLE DEDION METRIC					
This pack may include extra fasteners to cover different options					
ITEM	BASIC DESCRIPTION	PART NUMBER	QTY	USED ON	ILLUSTRATION
12	IL Rear washer 12" x 17" 40	BM12A11	16	FRS bearing off setup	
13	IM Plain washer 12" x 17" 40	BM12A11	8	FRS ply on off	
14	IN Plain washer 12" x 17" 40	BM12A11	16	DR shims washers	
15	IO Washer M10	BM10A10	16	Rear DeDion Caliper Carrier Hub	
16	IP Spring Washer M10	BM10A10	16	Rear DeDion Tube Caliper Carrier	
17	IQ Baller bolt 12" x 17" 40	BM12A11	4	Baller bolt needs on off	
18	IR Brake hose 12" x 17" 40	BM12A11	1	Braked brake hose	
19	IS Nylon 12" x 17" 40	BM12A11	4	Plugs on DeDion for brake pads	
20	IT Plug 180	BM10A18	4	Brake pins on DeDion	

x16  
x8

## TIPS

Swap the plain nuts on the droplinks for nylons.  
**Chris B**

Remember the driveshaft nuts are handed.  
**Grant P**

Torque up the bearing and ear before fitting the disc.  
**Dan D**

If you don't have an anti roll bar you will only have one bracket (for the right hand side) which holds the speed sensor.  
**Rich T**



## AND SPEED SENSOR (ONE SIDE ONLY)

### PARTS

- 1 Speed sensor

### TOOLS

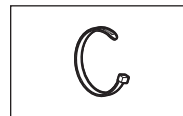

### FIXINGS

### TIPS

Ensure there is enough slack in the wire to allow for suspension travel.

**Tiago O**

Adjust sensor gap to approx. 0.8–0.9mm.

**Lloyd D**

## AND SPEED SENSOR (ONE SIDE ONLY)

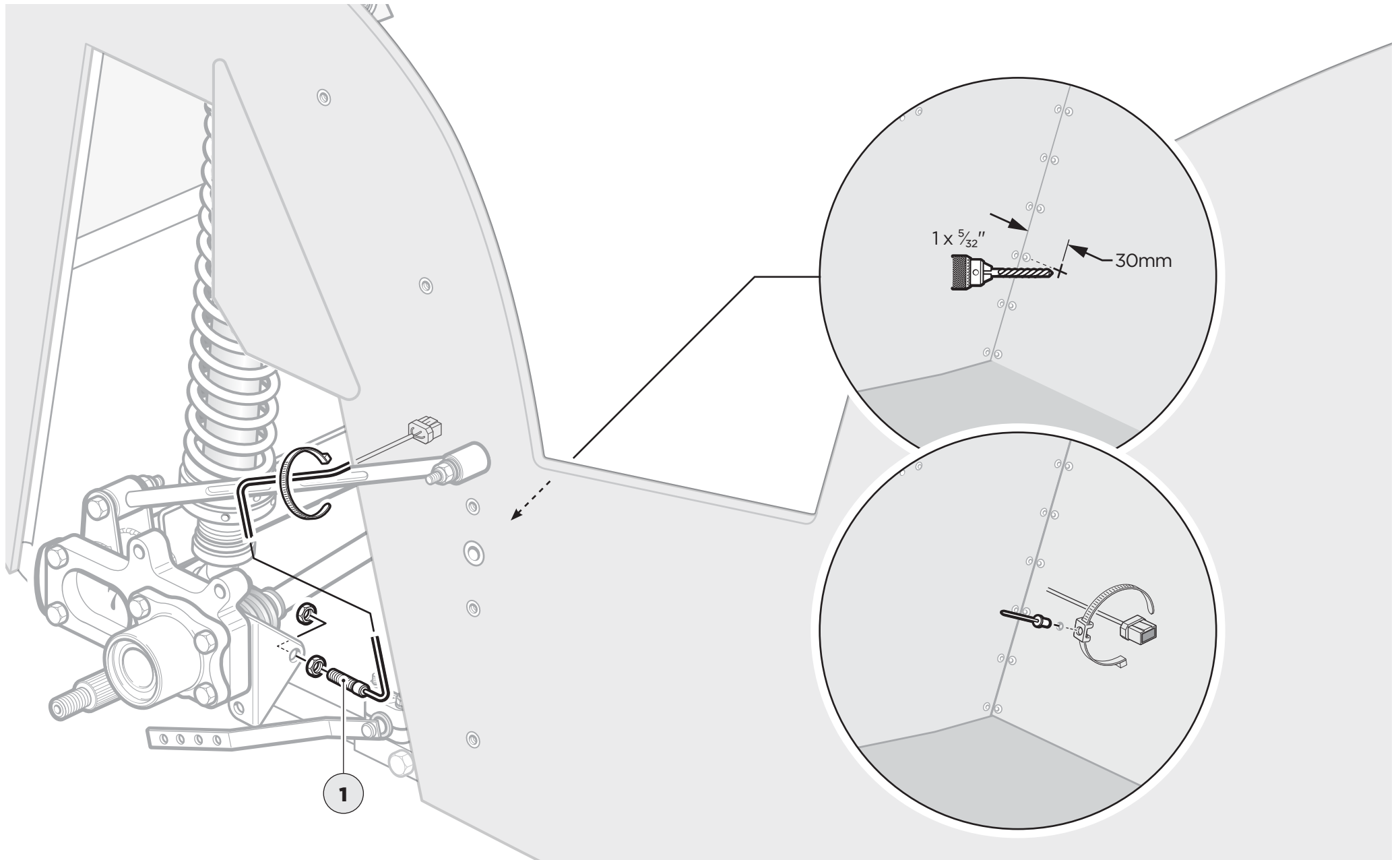



*Now is a good time to take some photos*



Have you applied for your IVA yet?

# JUST WING IT

## PARTS

- 1 Cycle wing
- 2 Wheel
- 3 Wheel nuts

## TOOLS

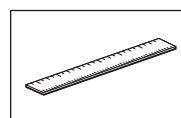
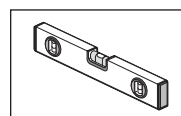
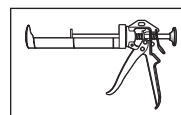
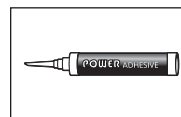

## FIXINGS

## TIPS

Key the wing & wingstay before using adhesive.

**John S**

You may need to bend the arms of the wingstay to make the wing level.

**Anthony L**

The  $\frac{1}{8}$ " hole you drilled earlier is for the indicator earth.

**Harry P**

The distance from the front edge of the wing to the wingstay should be 80mm.

**Lee A**

Do a 'dry run' first to make sure the wings are level before using power adhesive.

**Chris N**

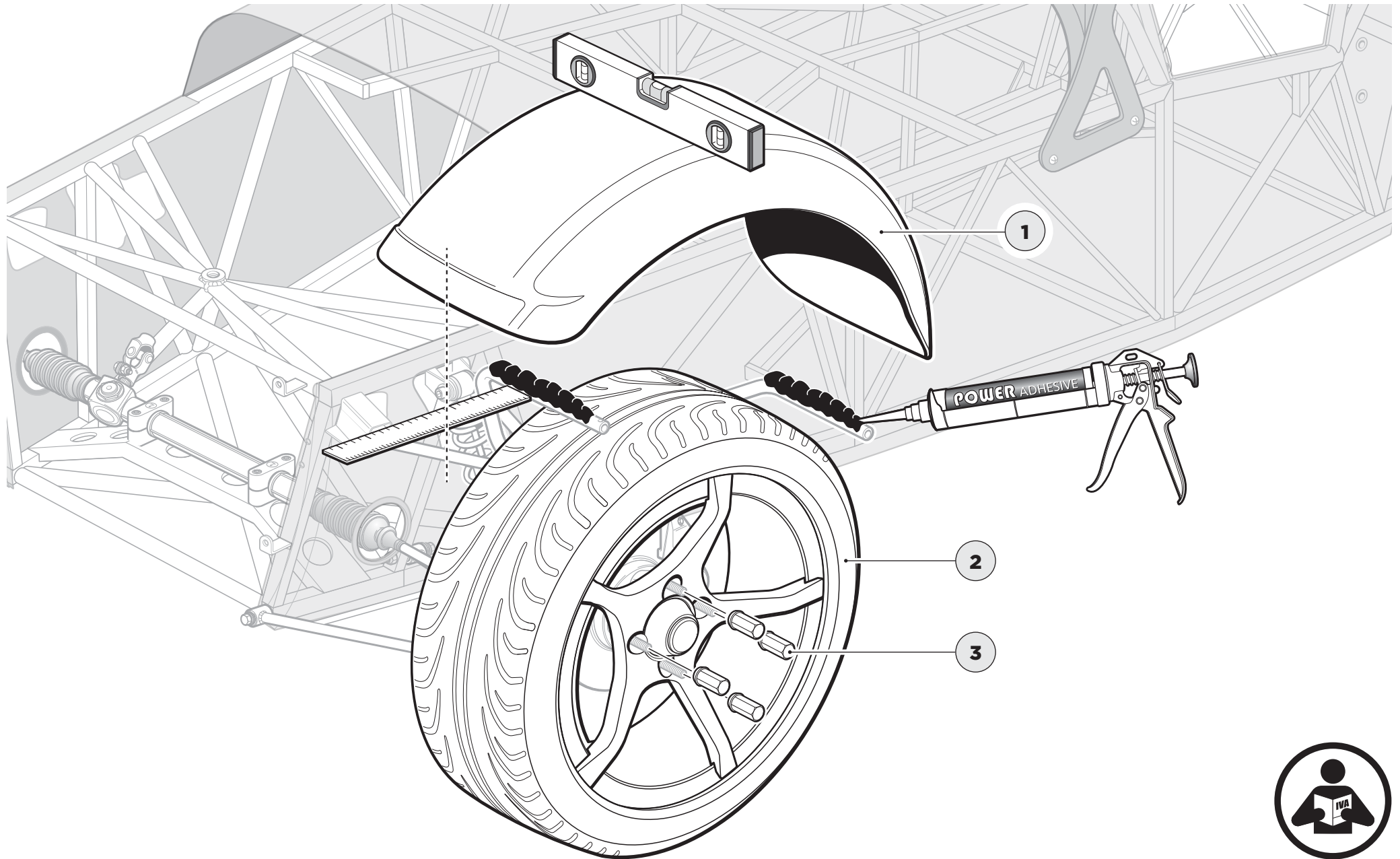

## TAPE IN PLACE FOR 24 HOURS

---

P A R T S

T O O L S

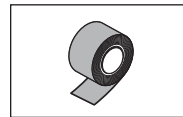

F I X I N G S

T I P S

**TAPE IN PLACE FOR 24 HOURS**

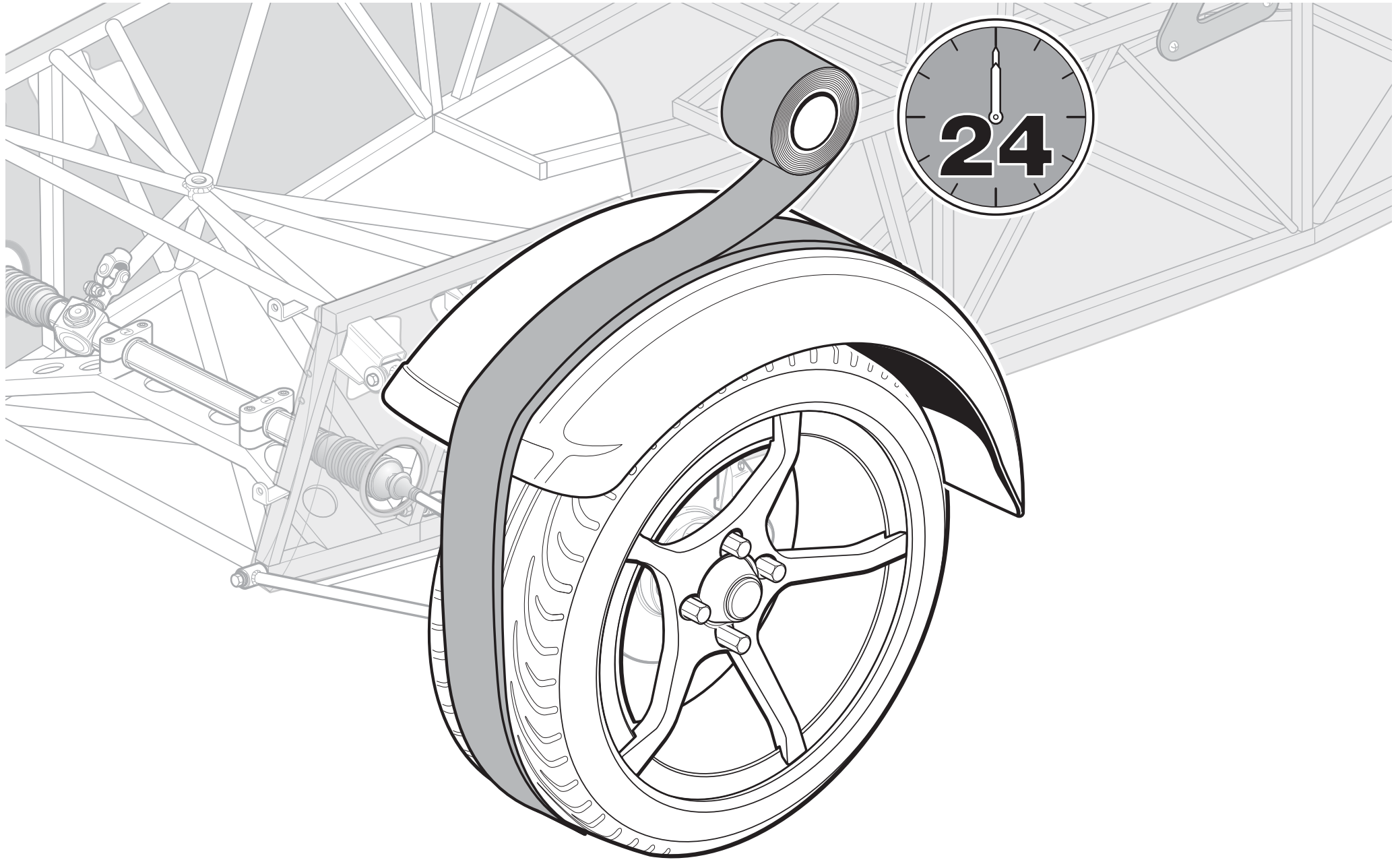

## SOME EXTRA ADHESIVE UNDERNEATH

### PARTS

### TOOLS

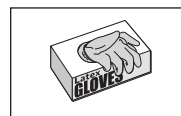
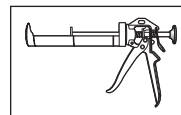
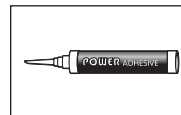

### FIXINGS

### TIPS

The WD40 will help spread the adhesive.

Mick F

## SOME EXTRA ADHESIVE UNDERNEATH

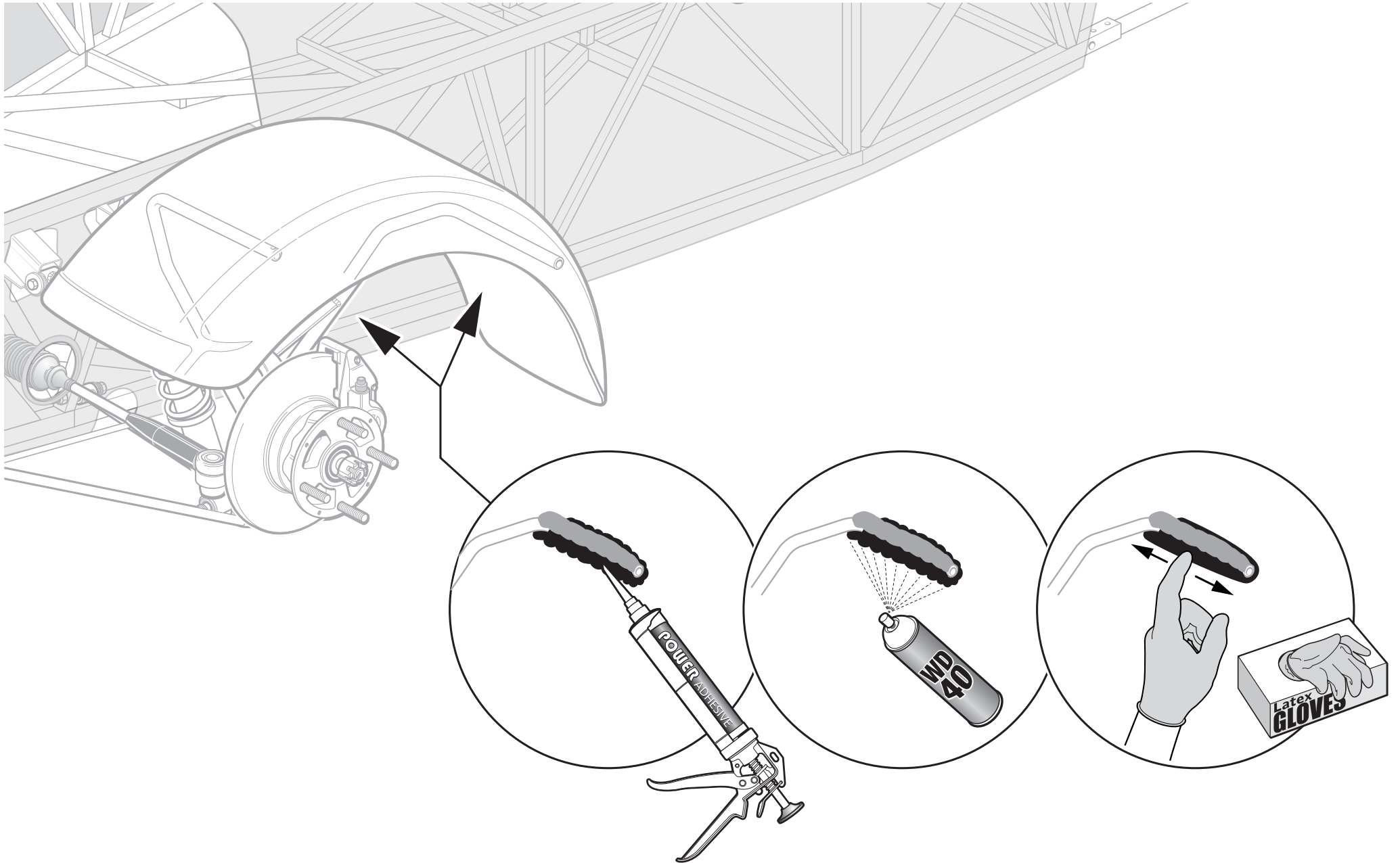

# FINISH WITH TRIM

## PARTS

## TOOLS

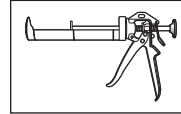
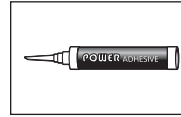

## FIXINGS

## TIPS

## FINISH WITH TRIM

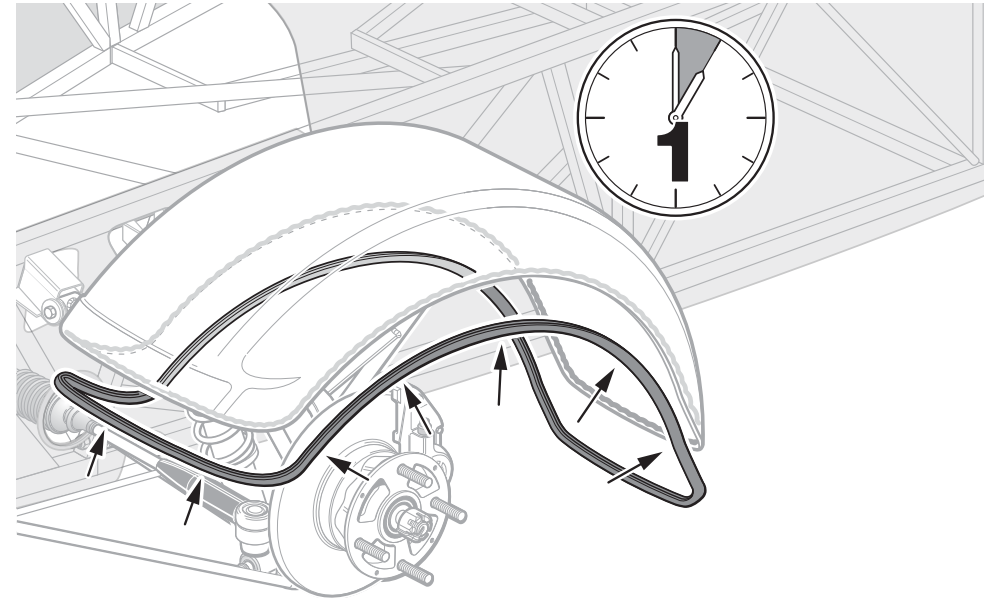
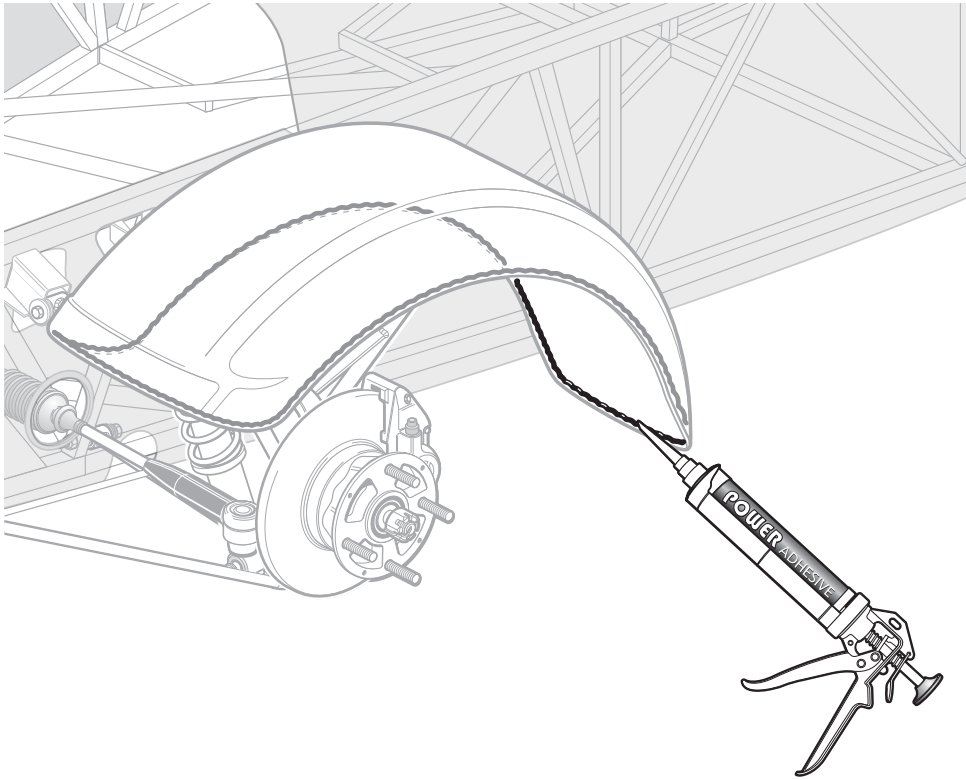

# FITTING THE REAR WINGS

## PARTS

**1** Rear wing

## TOOLS

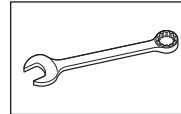
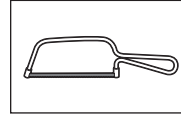
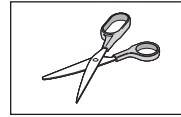

8mm

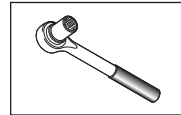

8mm

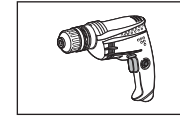

Sanding Drum

## FIXINGS

Pack <b>Q</b>		<b>CATERHAM</b>		31		
				PACK NUMBER		
				2FG12		
REAR WINGS						
This pack may include extra fasteners to cover different options						
ITEM	BASIC DESCRIPTION	PART NUMBER	QTY	USED ON	ILLUSTRATION	
1	OA	Self Drilling MS X 20	8MSX20	20	Rear Wings	
2	OB	Nylon Nut M5	N5NYS	10	Rear wings through boot	
3	OC	Flare Washer 3/16" X 3/4"	WFS16X34	30	Wing washers	
4	OD	Wing Piping 1/4" X 1"	7602	4m	Between wing and body	

x20

x10

x30

x4

## TIPS

Cut the supplied piping in half and it will be enough for both wings.

**Rich T**

Don't forget the fuel tank earth strap gets bolted to the RH wing bolt.

**Tiago O**

# FITTING THE REAR WINGS

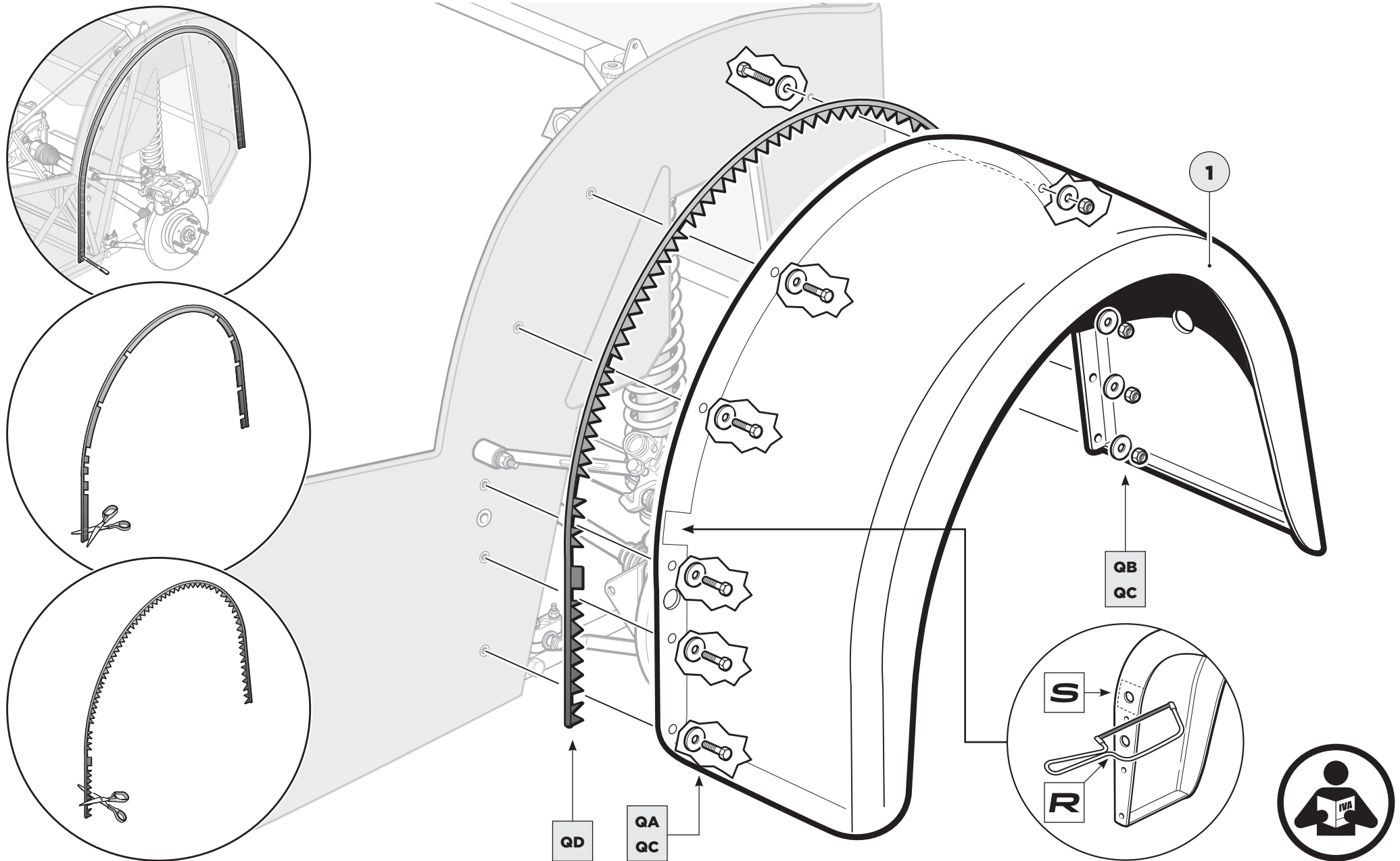

# AND THE WING PROTECTORS

## PARTS

- 1 Wing protector

## TOOLS

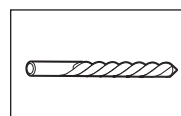
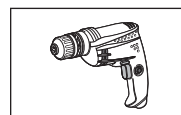
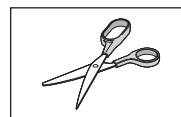

1/8"

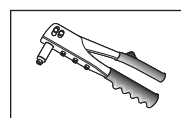

## FIXINGS

### For stainless steel protectors

<b>Pack O</b>		<b>CATERHAM</b>		<small>Part Number</small> <b>ZWS01</b>	
<b>WING PROTECTORS STAINLESS STEEL</b>					
<small>This pack may include extra fasteners to cover different options</small>					
ITEM	BASIC DESCRIPTION	PART NUMBER	QTY	USED ON	ILLUSTRATION
1	OA Reel 1/8" X 0.51"	1661-0414	30	Wing protector to wing	
2	OB Wing Plug	76901	2m	Between wing protector and wing	
<small>Drawings are for illustrative purposes only and are not to scale. Page 1 of 1</small>					

### For carbon fibre protectors

<b>Pack P</b>		<b>CATERHAM</b>		<small>Part Number</small> <b>ZWS02</b>	
<b>WING PROTECTORS CARBON FIBRE</b>					
<small>This pack may include extra fasteners to cover different options</small>					
ITEM	BASIC DESCRIPTION	PART NUMBER	QTY	USED ON	ILLUSTRATION
1	PA Reel Black 1/8" X 0.51"	1610-01046	30	Wing protector to wing	
2	PB Wing Plug	76901	2m	Between wing protector and wing	
<small>Drawings are for illustrative purposes only and are not to scale. Page 1 of 1</small>					

## TIPS

When drilling through protector start on the closest edge to the body. This will help the protector fit correctly.

Chris B

Carbon fibre protectors will not have the protective film shown.

Anthony L

# AND THE WING PROTECTORS

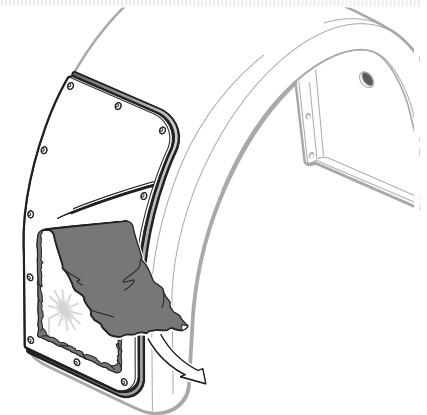
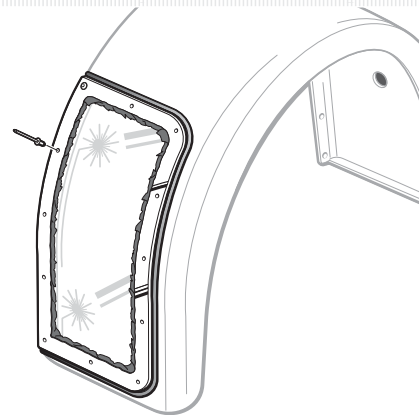
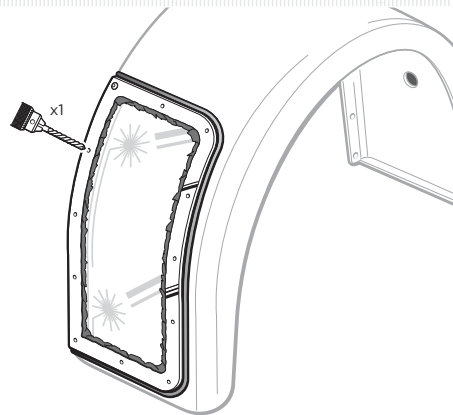
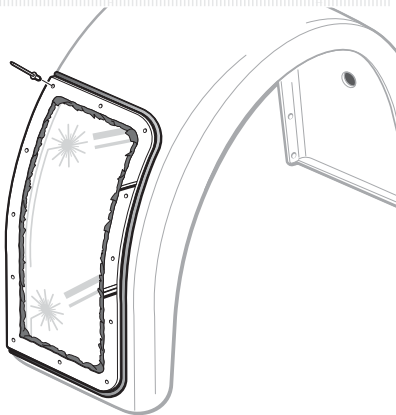
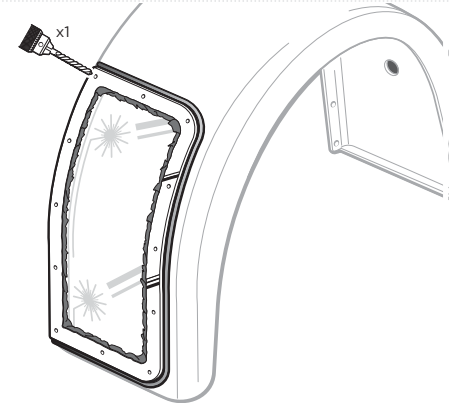
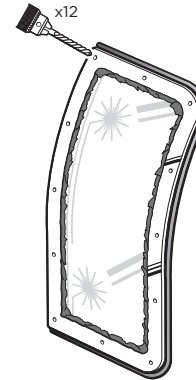
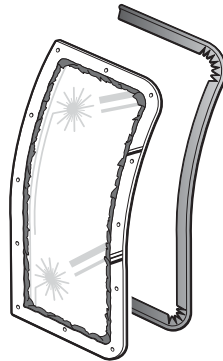
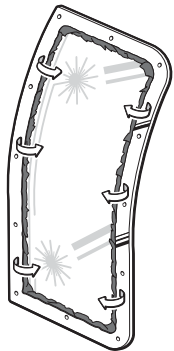
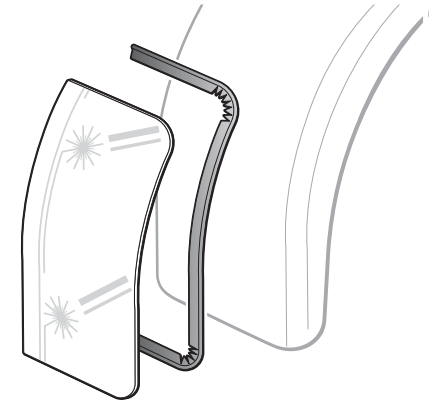
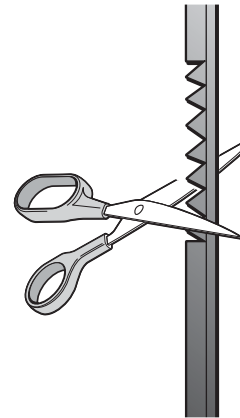
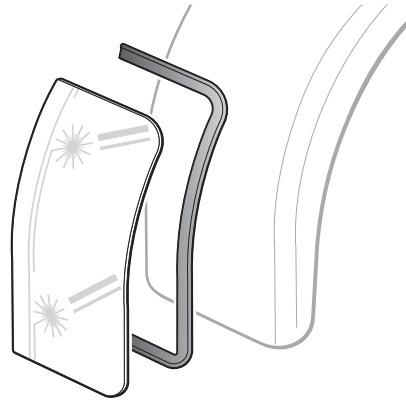
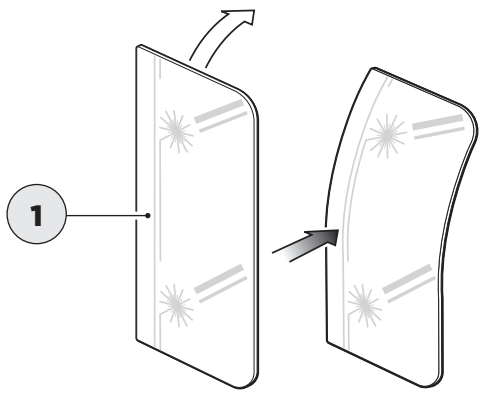

# FITTING THE LIGHTS

## PARTS

- 1** Side repeater
- 2** Rear light
- 3** Numberplate lamp

## TOOLS

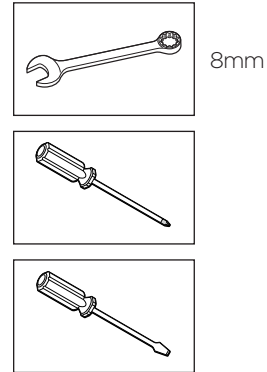

## FIXINGS

Pack C		CATERHAM		45	
				PACK NUMBER	
				30L002B	
FASTENER PACK - LIGHTING					
ITEM	BASIC DESCRIPTION	PART NUMBER	QTY	USED ON	ILLUSTRATION
1	CA Screw 10 x 37 Black Indicator	71060	6	Indicates connecting to indicator pad	
2	CB Screw 8 x 11 Black Indicator	71071	2	Side repeater parts on wingstay	
3	CC Screw 12 x 11* Self tapping	71070	4	Rear light cluster upper fixing	
4	CD Screw 12 x 11* Self tapping	71070	4	Rear light cluster lower fixing	

Drawings are for illustrative purposes only and are not to scale. Page 1 of 1

x4

x4

## TIPS

Use a cradle clip & cable tie to keep the rear light loom out of the way.

**John S**

Rubber grommet on rear light goes in the body not the wing.

**Jamie A**

Indicator repeater wires go through the wingstay.

**Chris B**

# FITTING THE LIGHTS

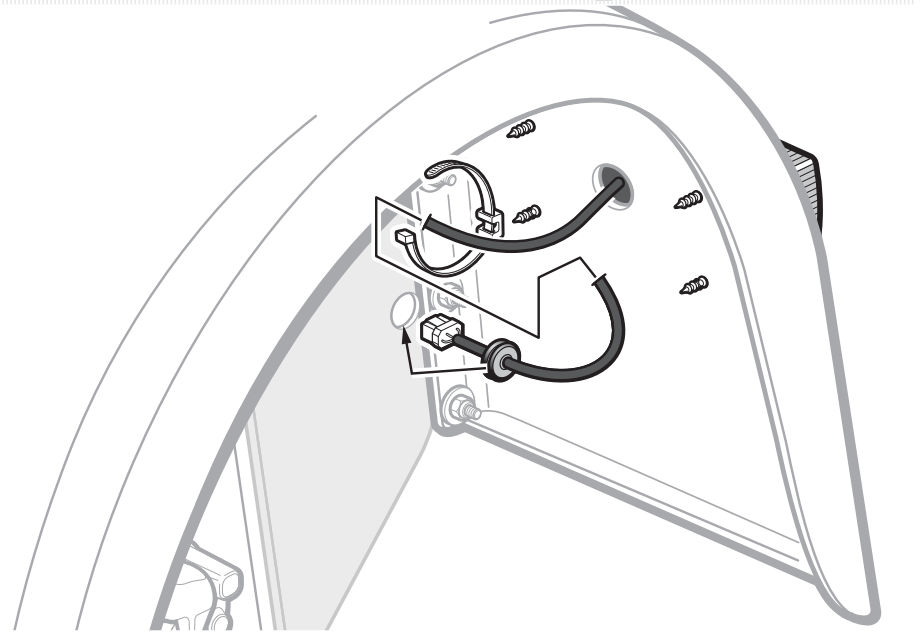
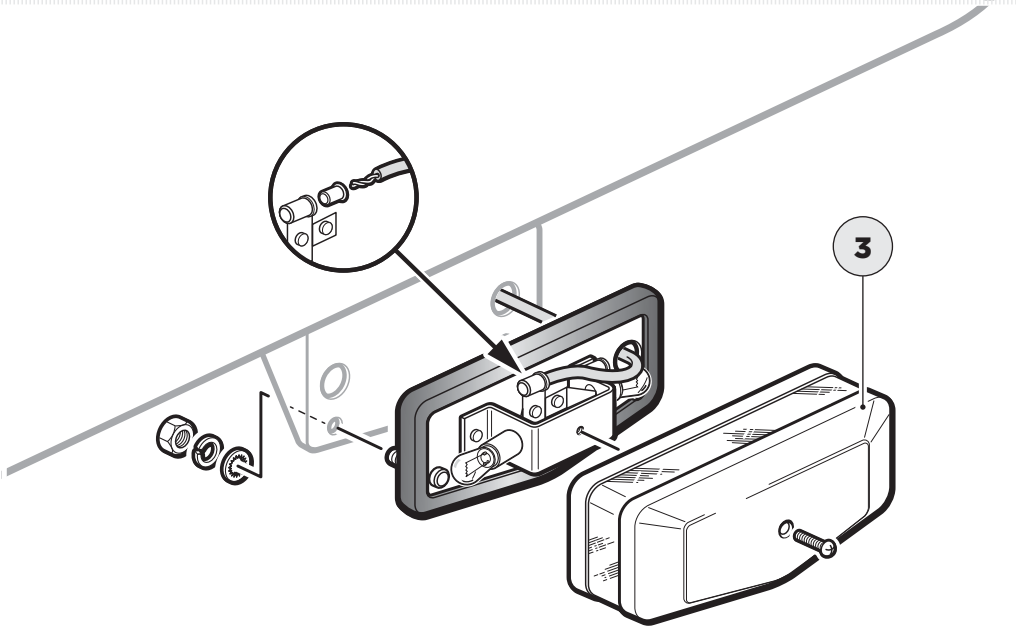
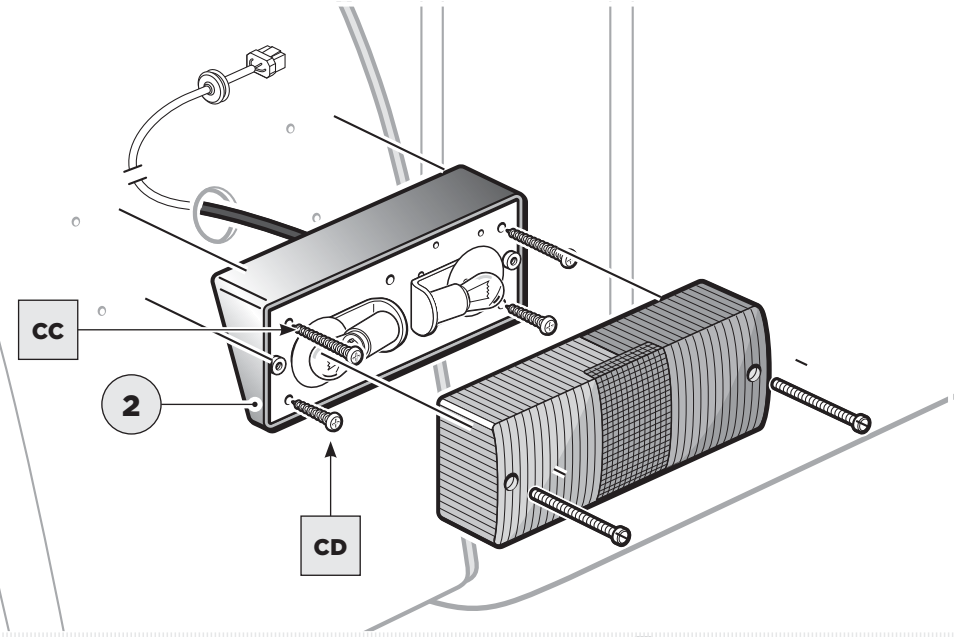
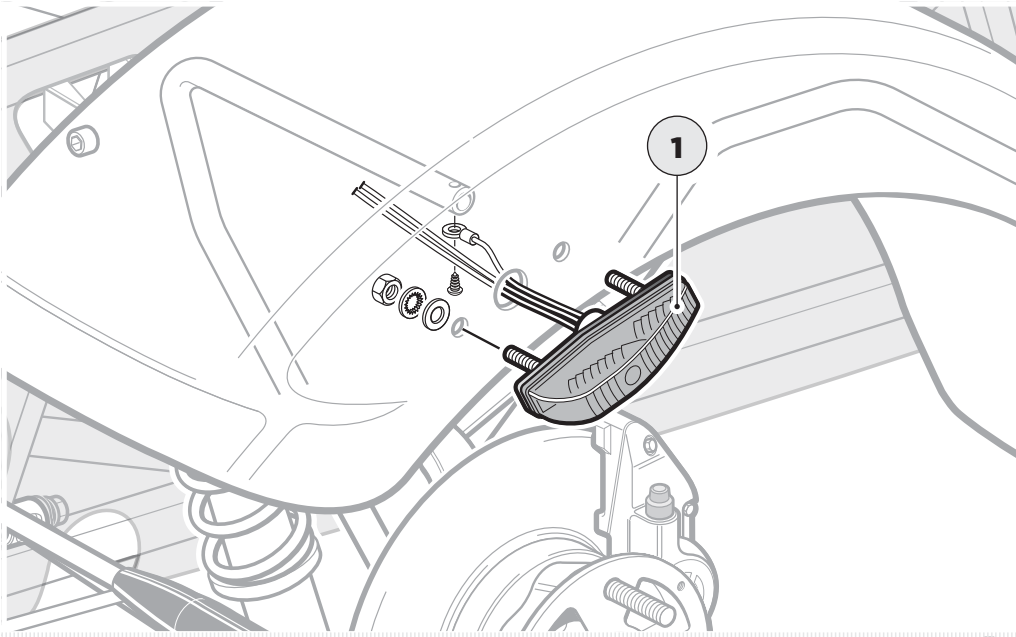

## FUSE BOX COVER & KNEE TRIM PADS

### PARTS

### TOOLS

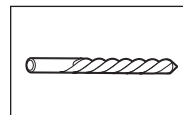
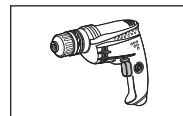

$\frac{5}{32}$ "

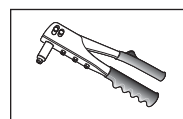
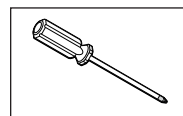

### FIXINGS

Chassis fastener pack ZCH01 supplied loose:

- Screw  $\frac{3}{4}$ " x 10
- Rivet  $\frac{5}{32}$  x 0.47"

### TIPS

*Building an Academy Car? If so you'll need to leave the riveting-in of the side panels until after you've fitted the roll cage (p154–155) as the front legs go behind the panel, not over the top of it.*

**John S**

# FUSE BOX COVER & KNEE TRIM PADS

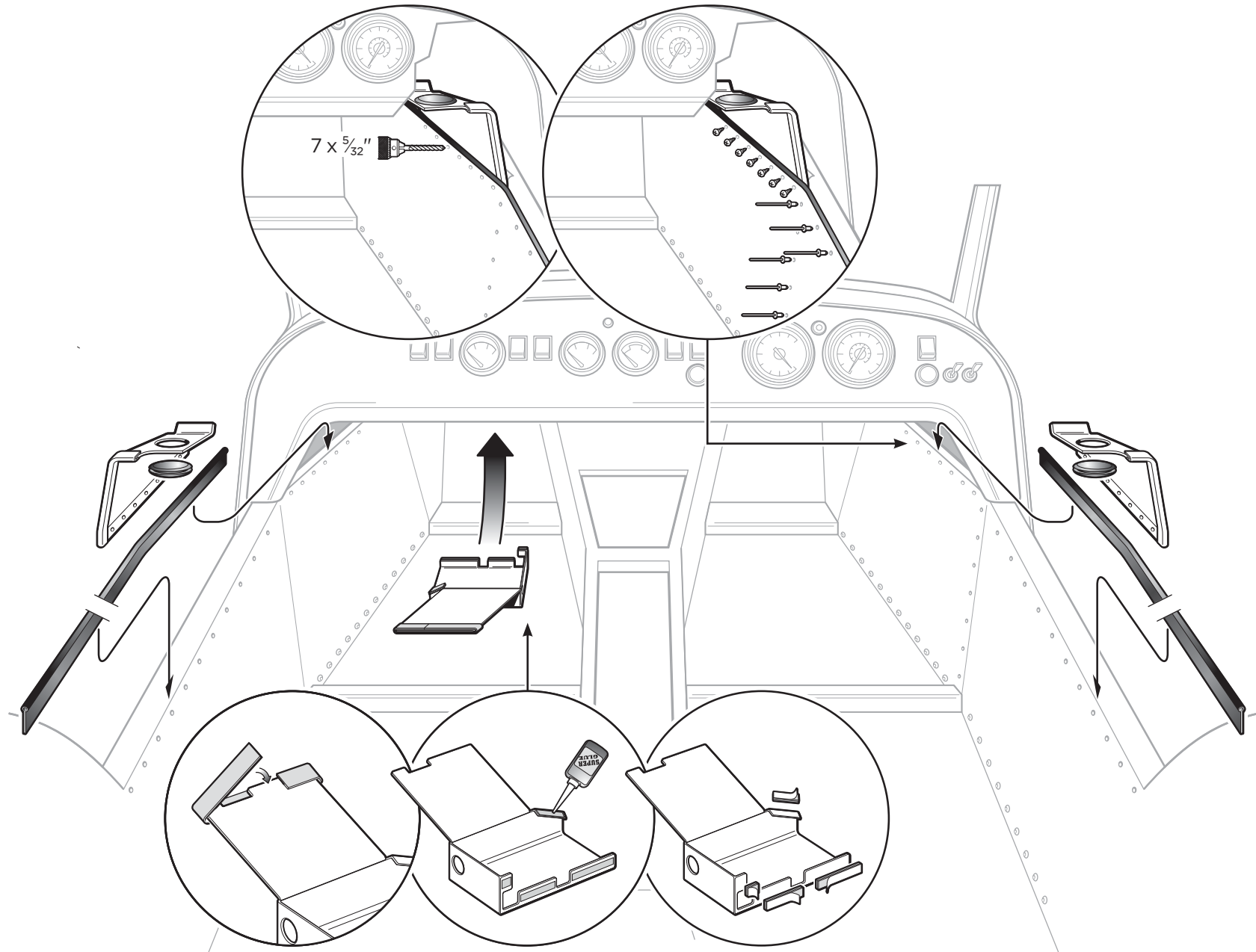

## FIT THE TUNNEL CARPET

### PARTS

### TOOLS



### FIXINGS

### TIPS

Spray on both tunnel panel and carpet.

**John K**

Allow the adhesive to go tacky before fitting.

**Harry P**

# FIT THE TUNNEL CARPET

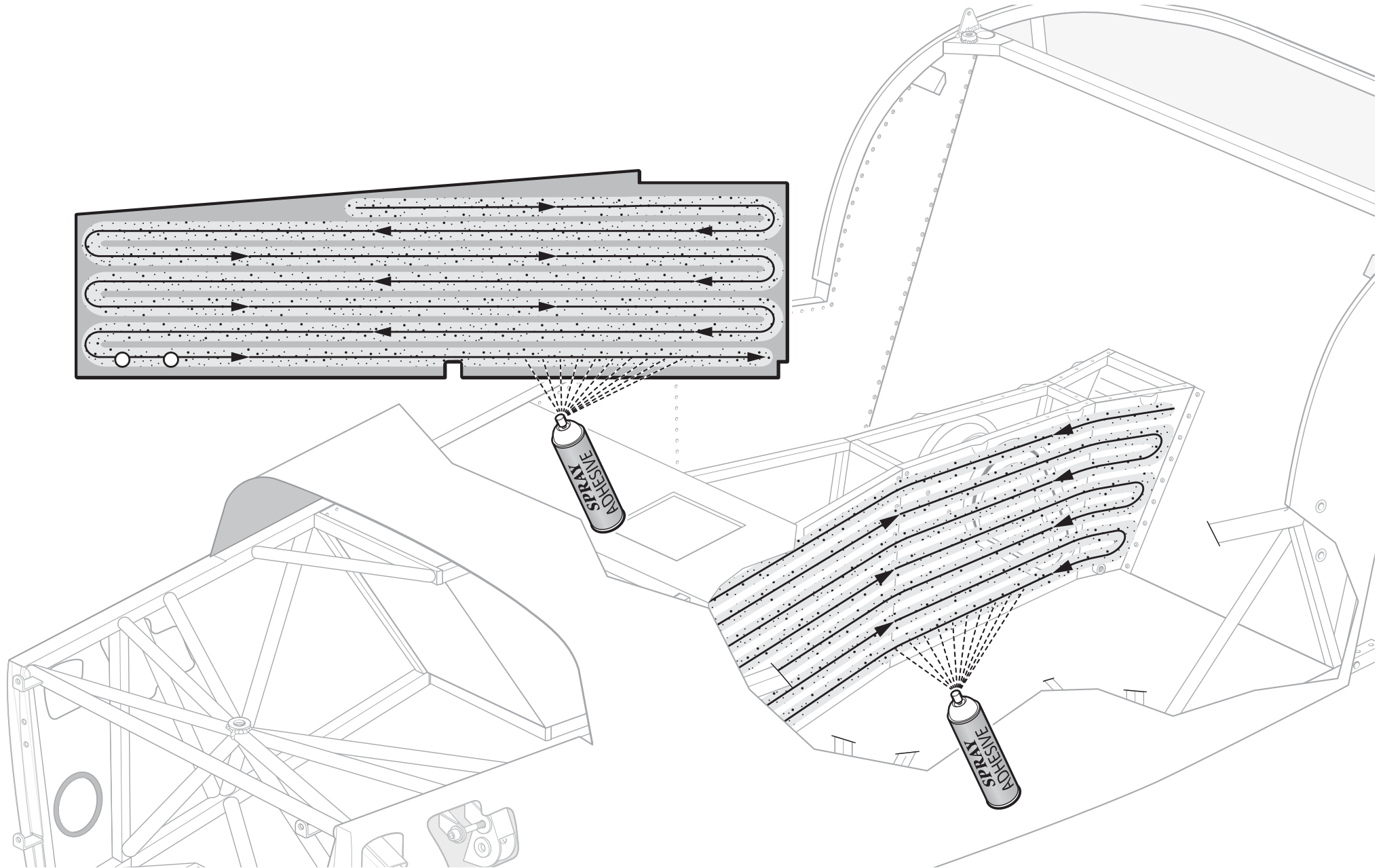

## AND THE BOOT CARPET

---

### PARTS

### TOOLS

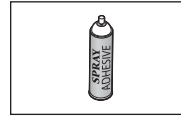

### FIXINGS

### TIPS

*S-Pack cars have a fully carpeted boot. It's something of a jigsaw pattern, but the parts are simply glued in place like the bigger bits.*

**John S**

## AND THE BOOT CARPET

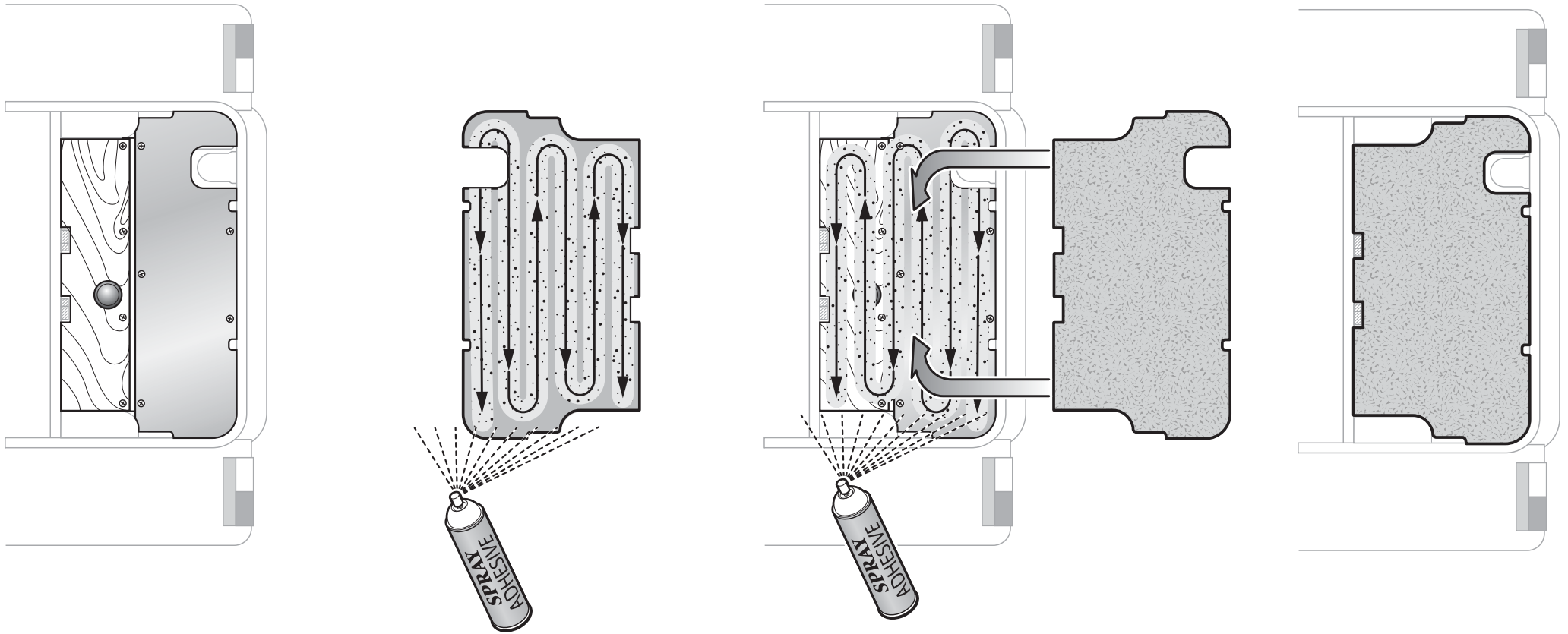

# THIS IS A COVER UP

## PARTS

- 1 Fuel filler cove
- 2 Tunnel closing panel

## TOOLS

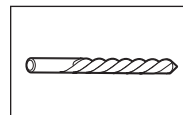
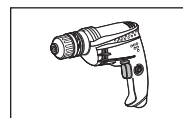

$\frac{5}{32}$ "

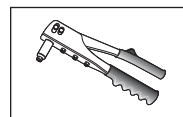
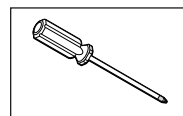

## FIXINGS

### Supplied loose:

- Rivets
- Screws

## TIPS

The fuel filler cover just screws to the boot floor.  
Drill two holes and use self tapping screws.

**Rich T**

# THIS IS A COVER UP

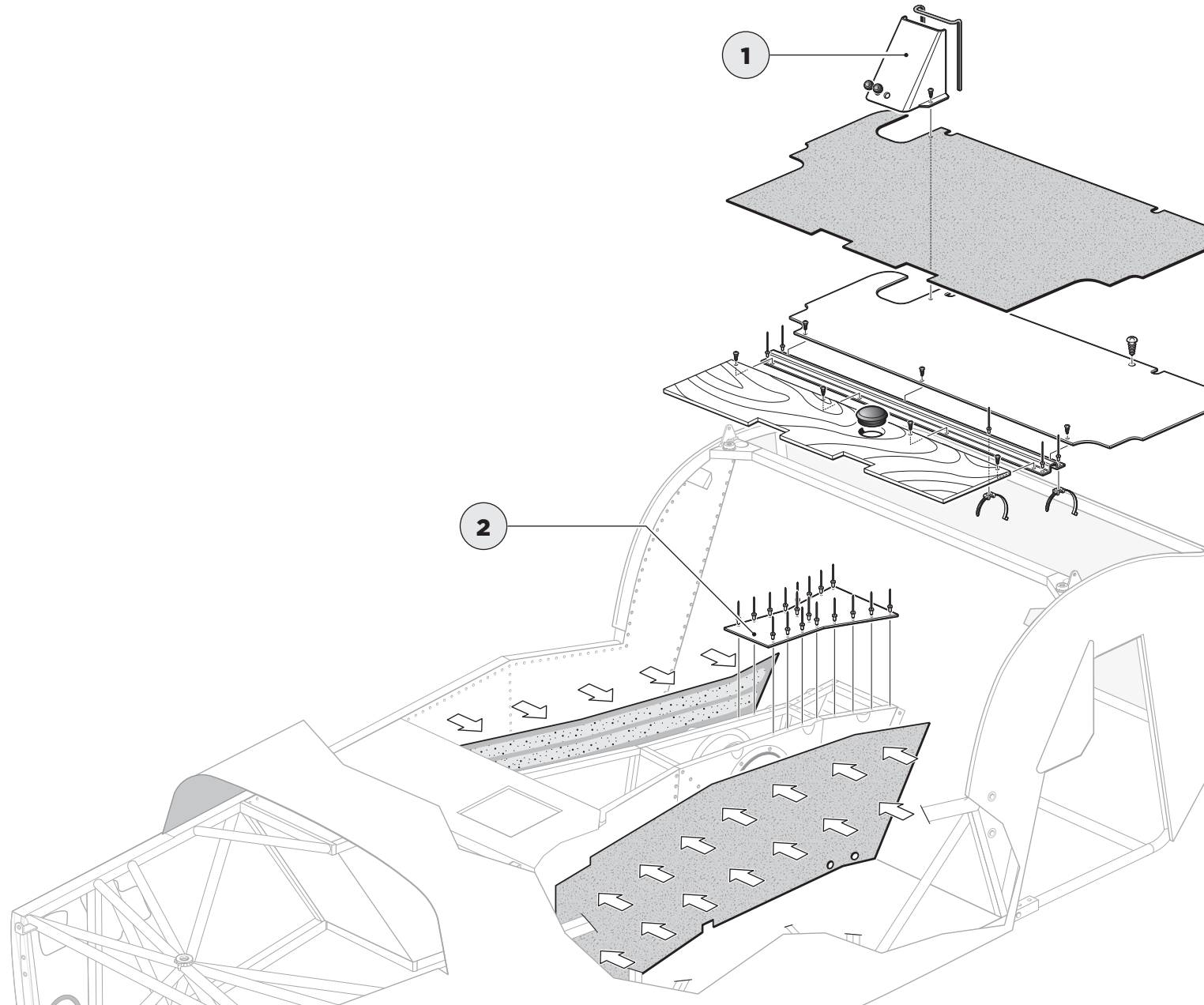

## NOW FIT THE TUNNEL TOP

### PARTS

### TOOLS

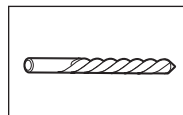
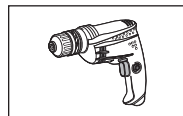

1/8"

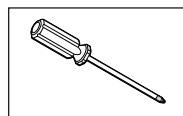

### FIXINGS

### TIPS

The hole can be seen if you flip the tunnel top over.

Mick F

## NOW FIT THE TUNNEL TOP

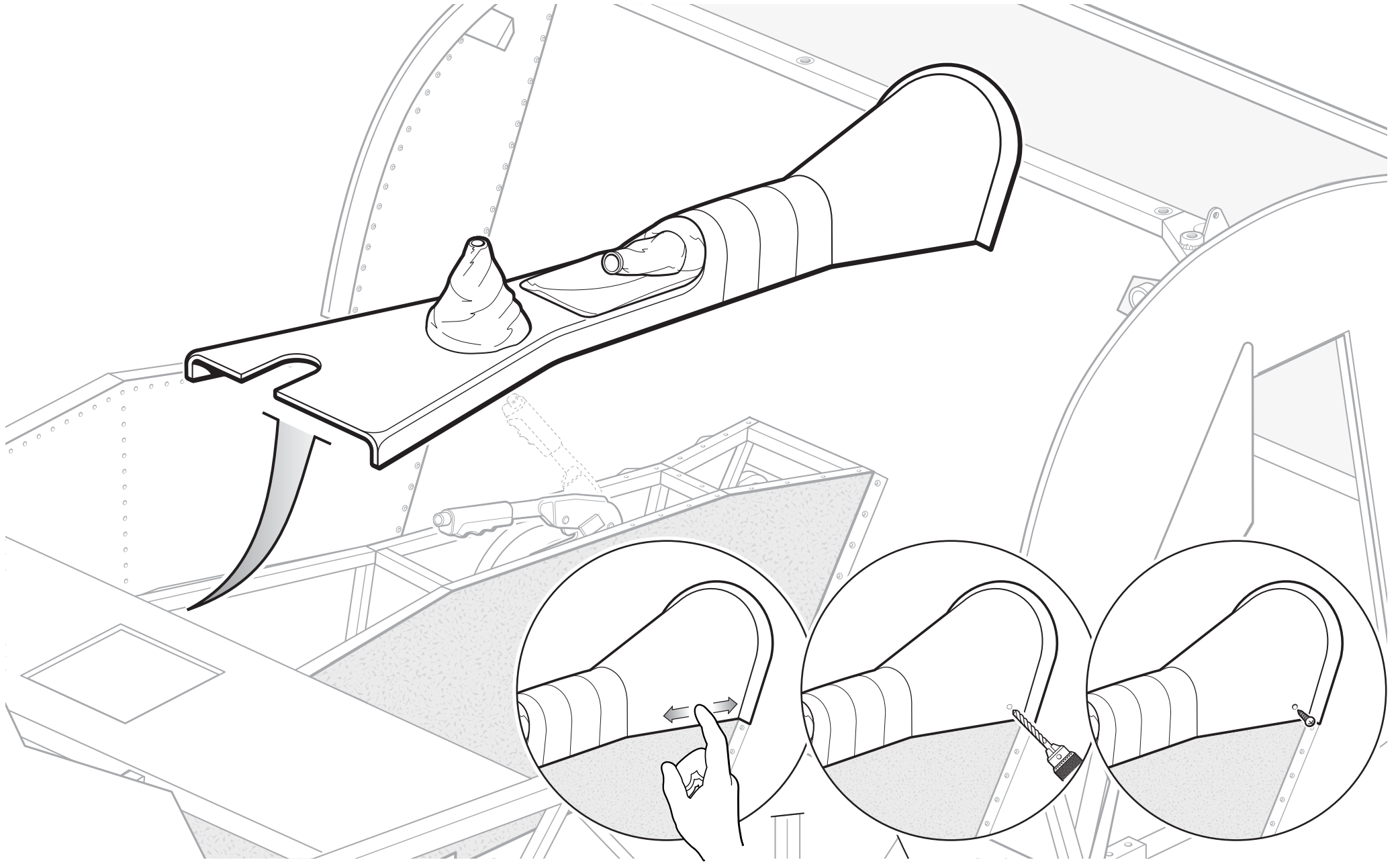

# BELT UP

## PARTS

## TOOLS



## FIXINGS

Supplied with seat belts

## TIPS

*These will be loosely fitted already – you'll need to tighten & torque.*

**Chris N**

# BELT UP

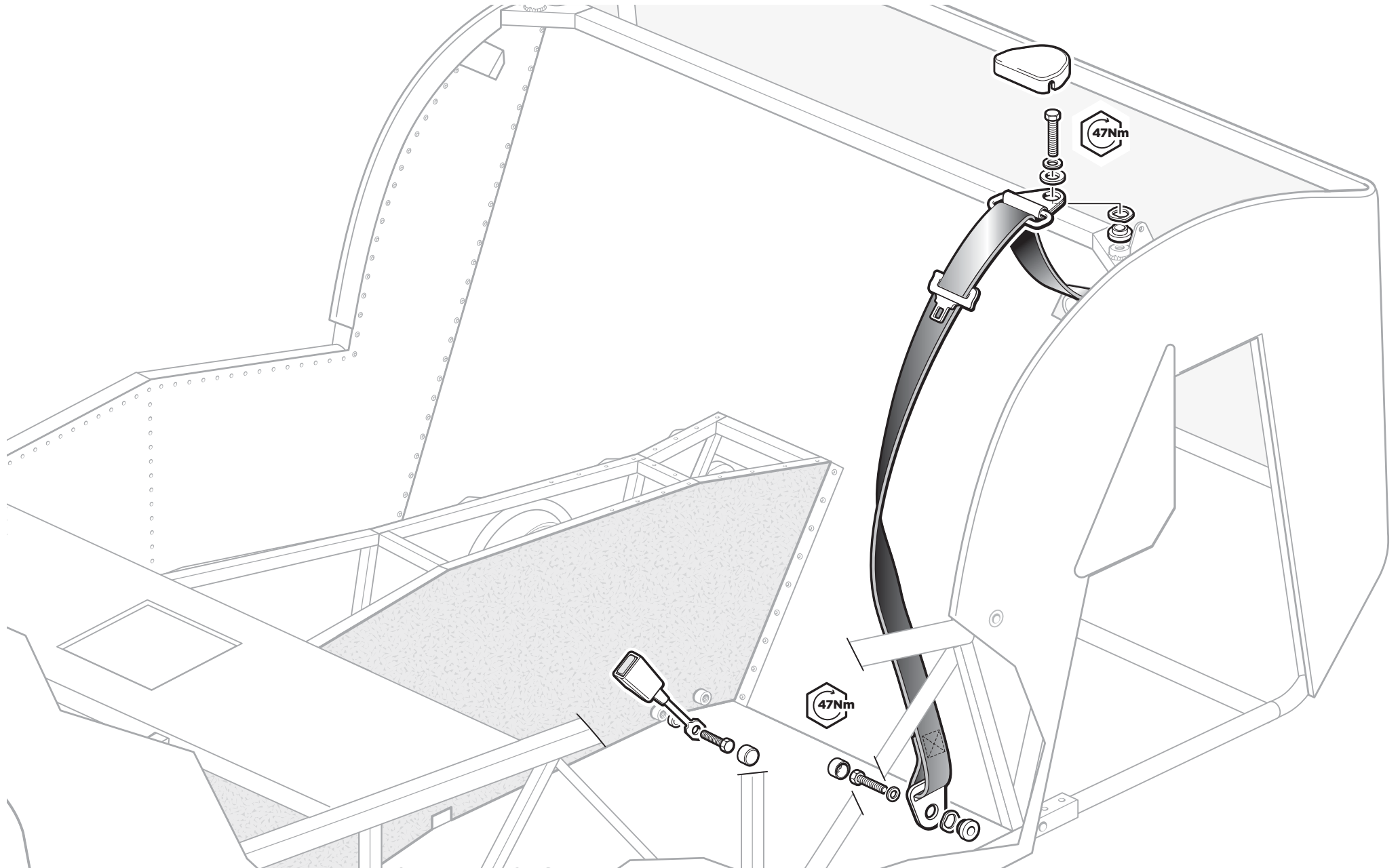

## FITTING THE FOUR-POINT HARNESS

### PARTS

### TOOLS

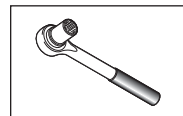

17mm



### FIXINGS

All fixings supplied with the harnesses

### TIPS

The buckle is attached to a lap strap and this should be fitted to the tunnel side.

**Chris N**

For Academy cars with Schroth Harnesses see Page 148.

**Dan P**

# FITTING THE FOUR-POINT HARNESS



## IMPORTANT

For Academy cars with Schroth Harnesses see page 148

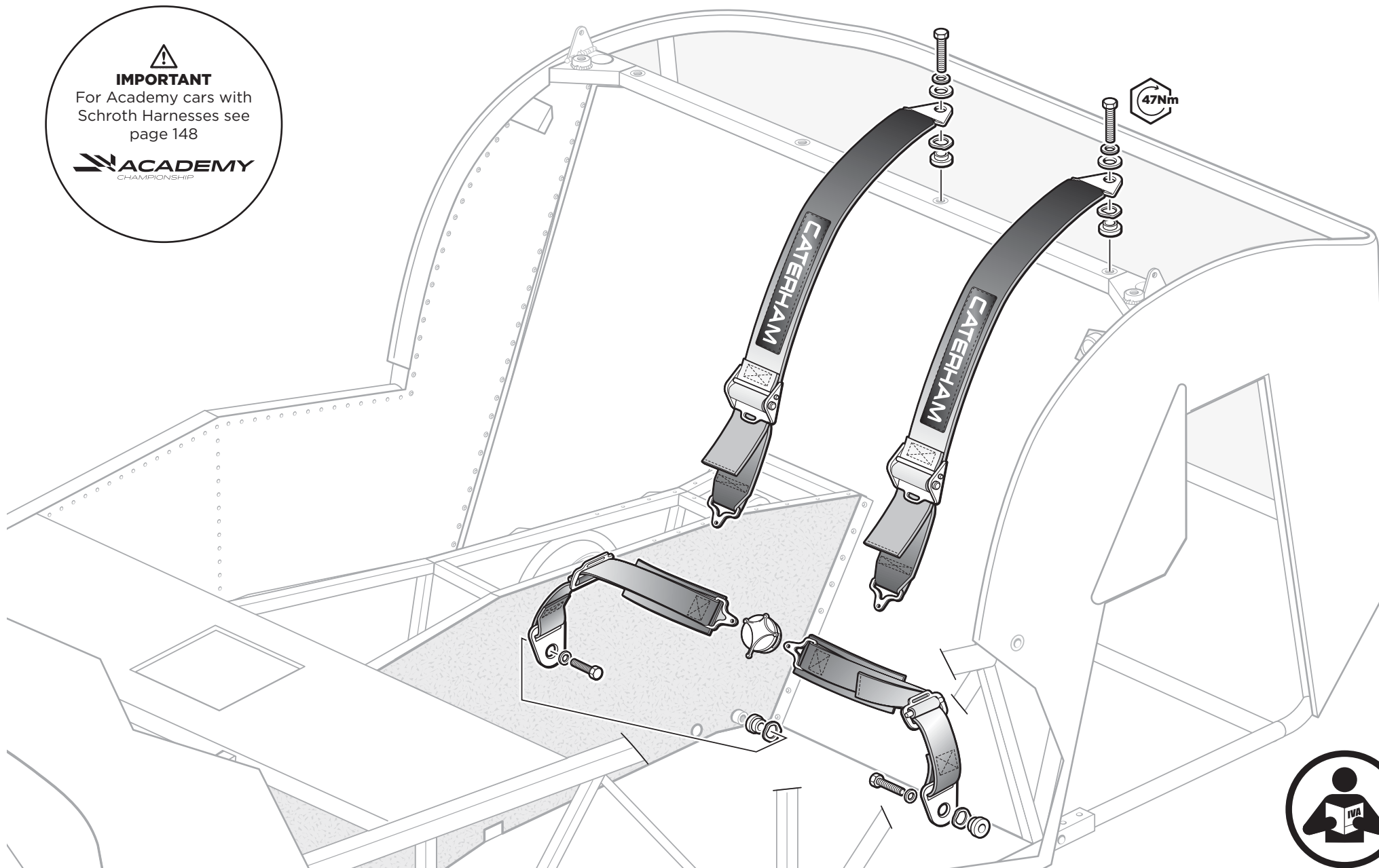

### SHOULDER STRAP MOUNTING ORIENTATION

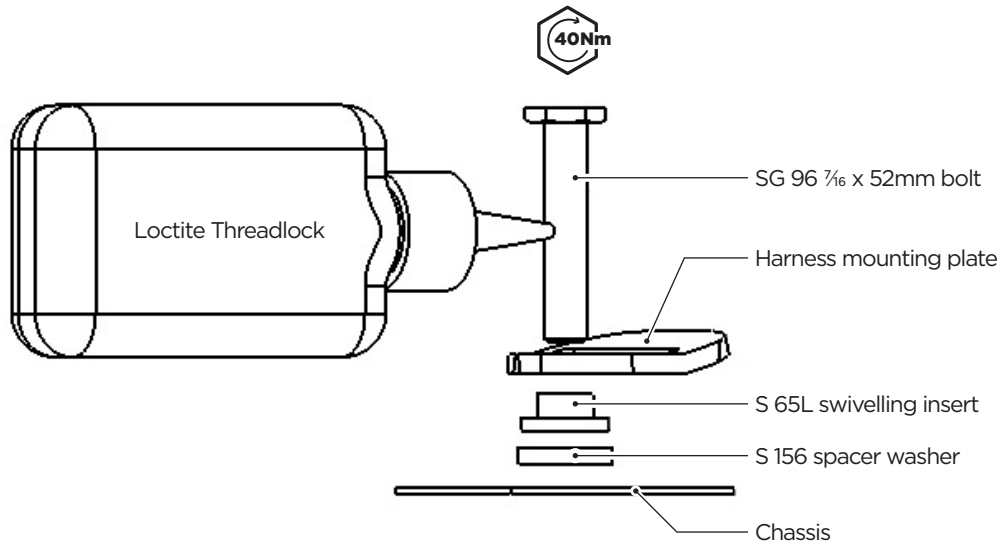

### WAIST STRAP MOUNTING ORIENTATION

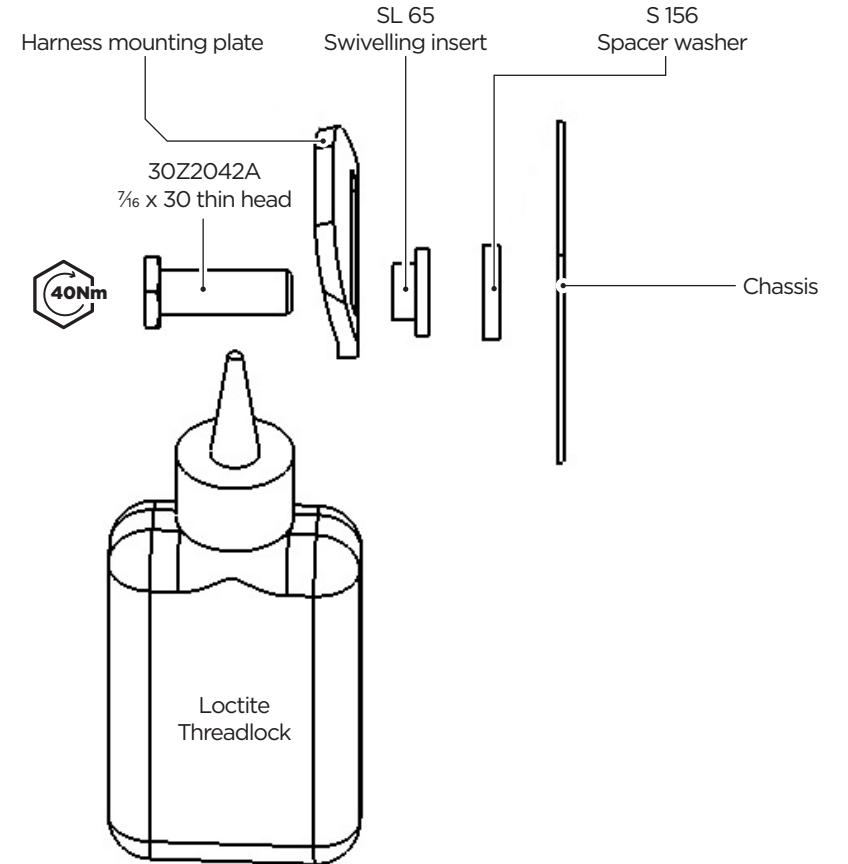

### CRUTCH STRAP MOUNTING ORIENTATION

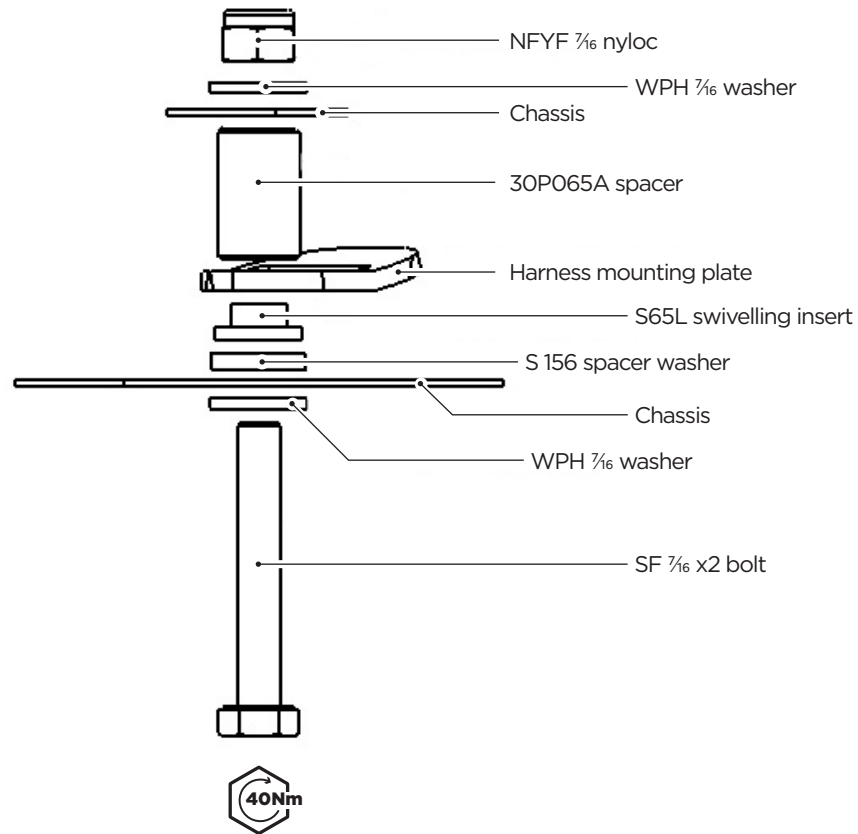

# FITTING THE SIX-POINT HARNESS

## PARTS

## TOOLS

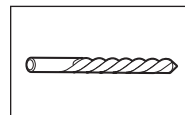
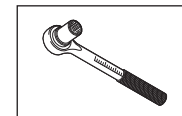
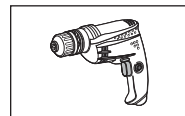

7/16"

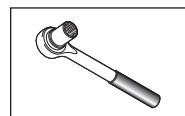

16mm  
17mm

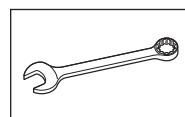

16mm  
17mm

## FIXINGS

All fixings supplied with the harnesses

## TIPS

The buckle is attached to a lap strap and this should be fitted to the tunnel side.

Lee A

# FITTING THE SIX-POINT HARNESS

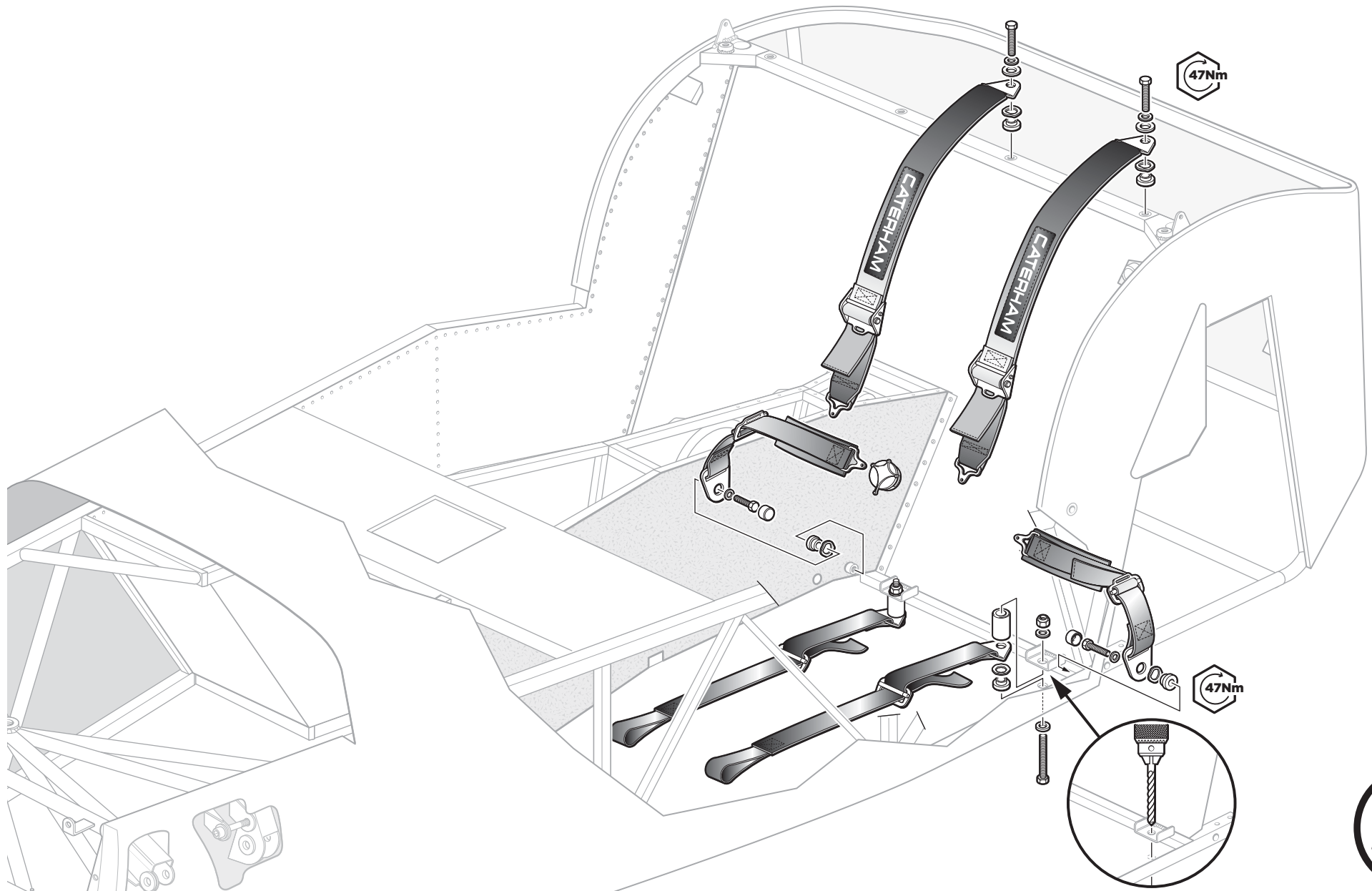

# FITTING CLOTH OR LEATHER SEATS

## PARTS

- 1** Seat
- 2** Seat base
- 3** Headrest

## TOOLS

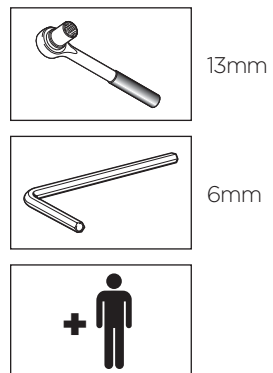

## FIXINGS

Pack <b>L</b>		<b>CATERHAM</b>		62	
				3021058B	
<b>CLOTH/LEATHER SEATS ALL CARS</b>					
<small>This pack may include extra fasteners to cover different options</small>					
ITEM	BASIC DESCRIPTION	PART NUMBER	QTY	USED ON	ILLUSTRATION
1	LA Cleathead Bolt M8 X 20 Grade 12.9	SM2H0020	4	Through seat runner & floor	
2	LB Nyloc Nut M8	N8N78	4	Under floor	
3	LC Plain Washer M8 X 30	WPH8030	4	Under floor	

Drawings are for illustrative purposes only and are not to scale. Page 1 of 1

x4  
x4  
x4

## TIPS

Loosely fit the rear bolts to help locate the front.  
**Dan D**

Nip up all bolts once fitted.  
**Anthony L**

# FITTING CLOTH OR LEATHER SEATS

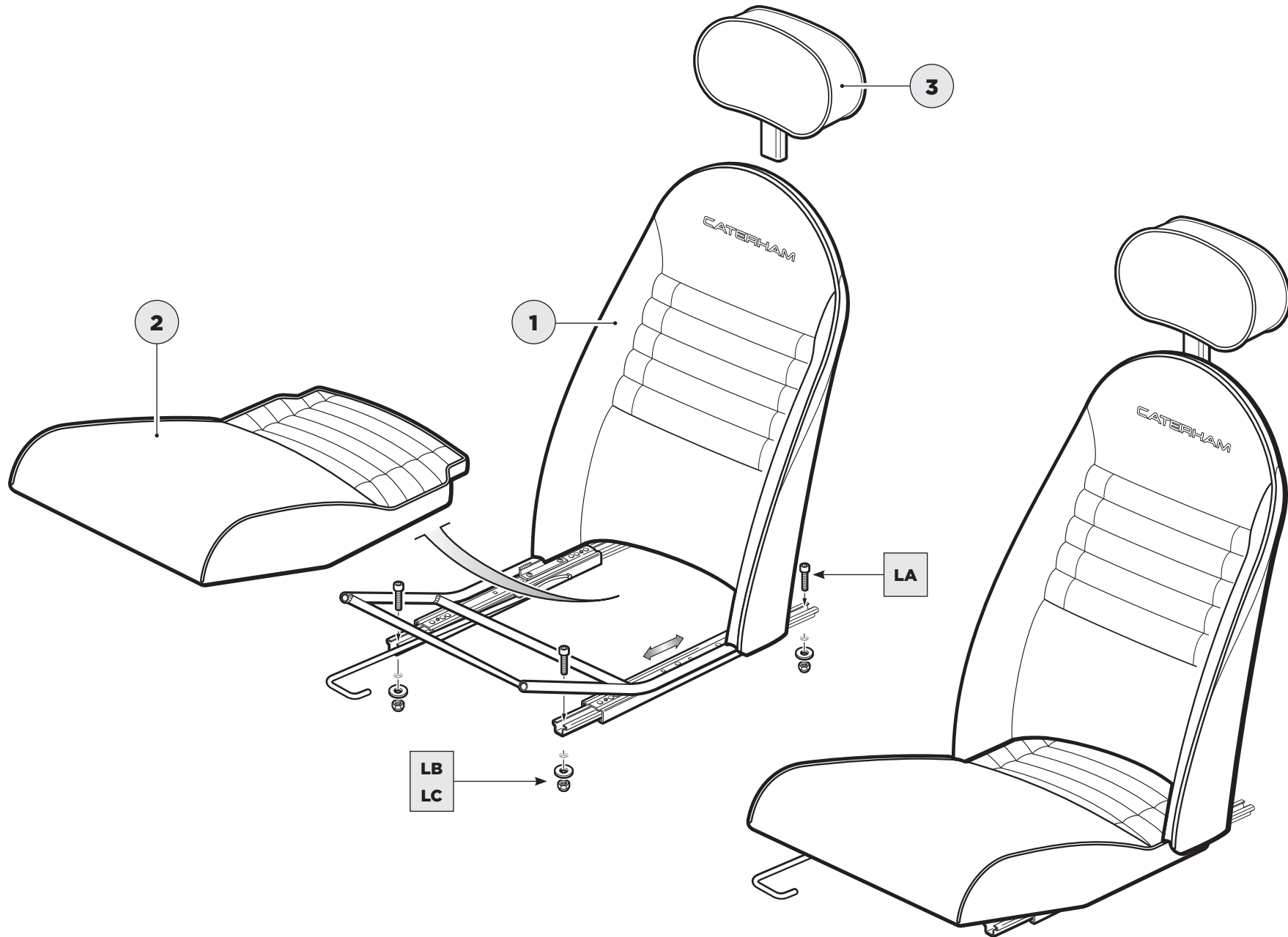

# OR FITTING THE RACE SEATS

## PARTS

- 1 Seat
- 2 Adjustable runner
- 3 Fixed seat spacer

## TOOLS

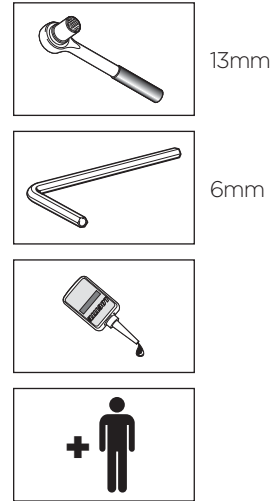

## FIXINGS

### For fixed seats

Pack M		CATERHAM		Part Number 63	
		PACK NUMBER		3021062A	
SEATS FIXED TILLET RACING					
This pack may include extra fasteners to cover different options					
ITEM	BASIC DESCRIPTION	PART NUMBER	QTY	USED ON	ILLUSTRATION
1	MA Caphead Bolt M8 X 20	8MCH8X20	4	Spacer box section to seat	
2	MB Caphead Bolt M8 X 20	8MCH8X20	4	Floor to mount in spacer box section	
3	MC Spring Washer 5/16"	W5/16S16	8	Bolt heads	
4	MD Washer 5/16" X 1 1/4"	W5/16X1 1/4	4	Under floor	
5	ME Washer M8 X 18	W8M8X18E1	4	Spacer box section to seat	
7	MF Spacer Block Plastic	TW2	3	Seat spacer	
8	MG Spacer Block Plastic	TW3	5	Seat spacer	

x4  
x4  
x8  
x4  
x4  
x3  
x5

### For adjustable seats

Pack N		CATERHAM		Part Number 64	
		PACK NUMBER		3021063A	
SEATS ADJUSTABLE TILLET RACING					
This pack may include extra fasteners to cover different options					
ITEM	BASIC DESCRIPTION	PART NUMBER	QTY	USED ON	ILLUSTRATION
1	NA Caphead Bolt M8 X 20	8MCH8X20	4	Runner to seat	
2	NB Caphead Bolt M8 X 20	8MCH8X20	4	Runner to floor	
3	NC Washer 5/16" X 1 1/4"	W5/16X1 1/4	4	Under floor	
4	ND Nylon Nut M8	N8NY18	4	Under floor	
5	NE Spacer Block Plastic	TW2	3	Seat spacer	
6	NF Spacer Block Plastic	TW3	5	Seat spacer	

x4  
x4  
x4  
x4  
x3  
x5

## TIPS

Put a bit of Loctite on bolts that go into the seat on the runner version.  
**Chris B**

Runners / seat spacers can be fitted to seat before putting in car.  
**Mick F**

Loosely fit the rear bolts to help locate the front.  
**Harry P**

The fixed position seat is for the passenger side!  
**Chris N**

# OR FITTING THE RACE SEATS

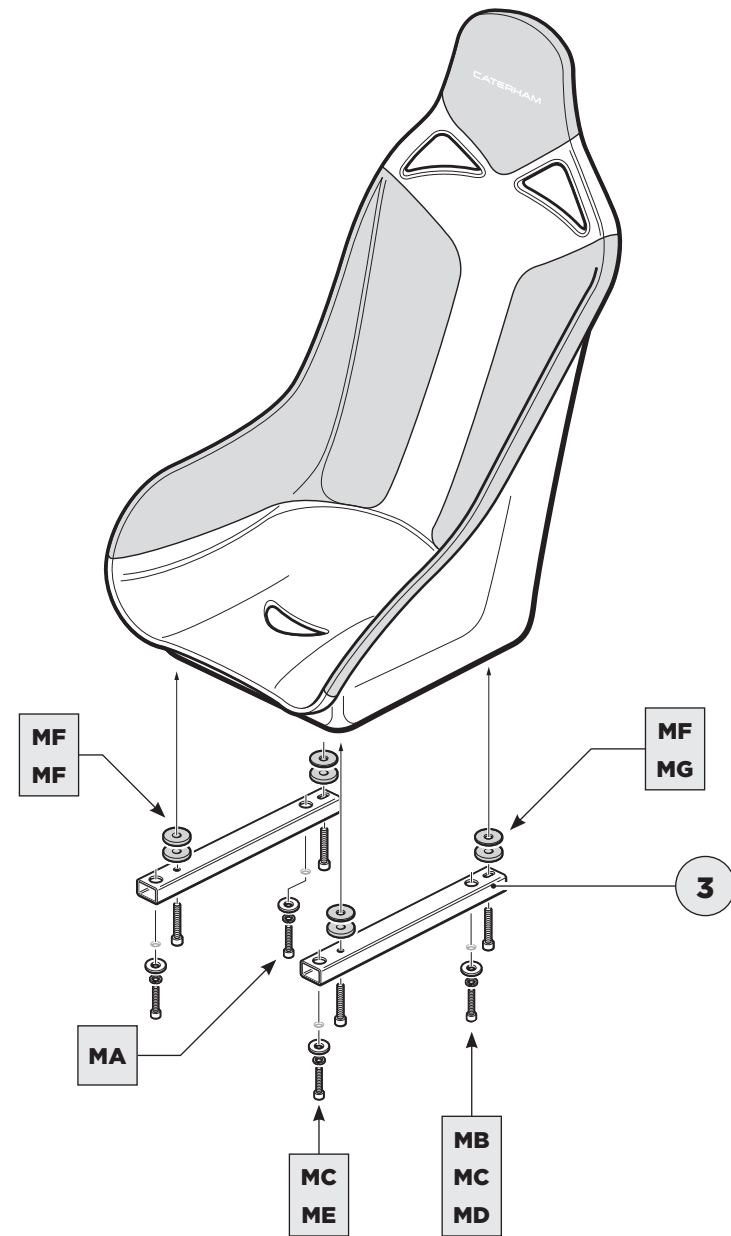
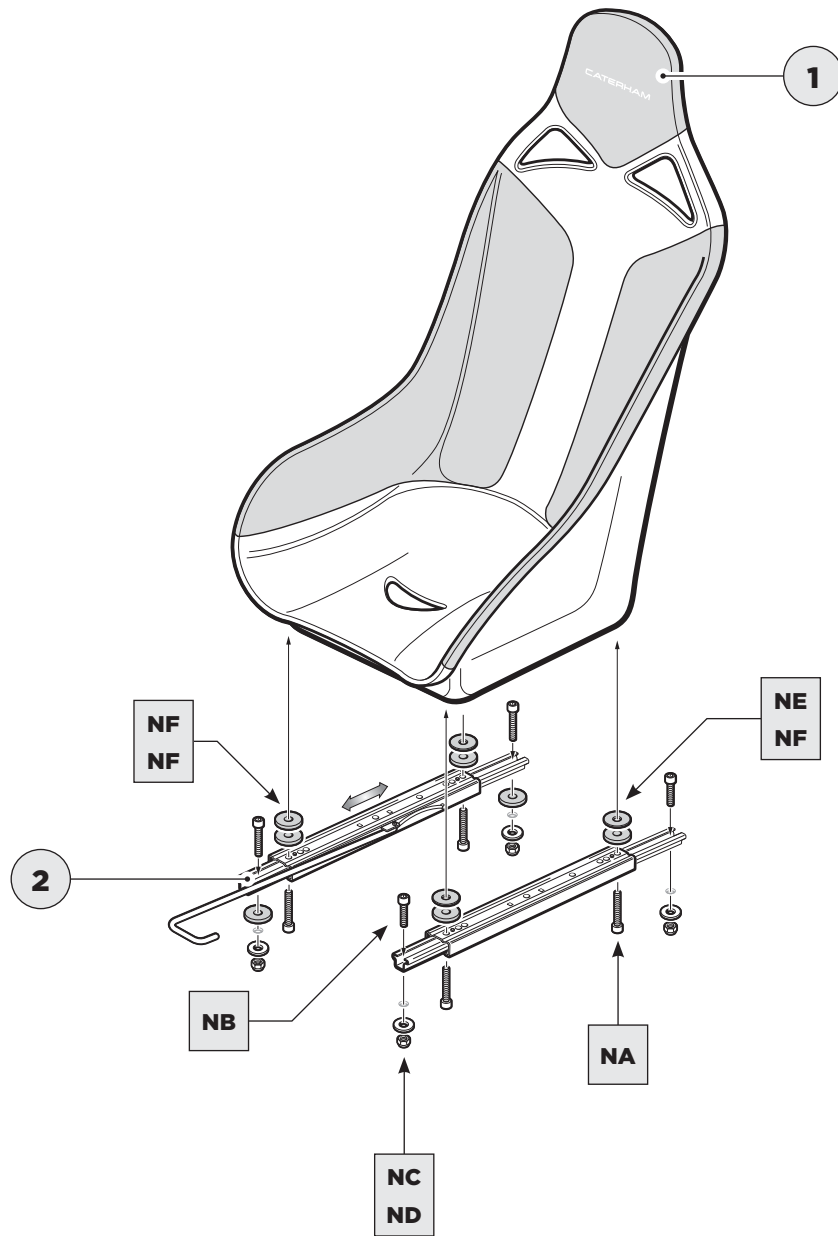

# FITTING THE ROLL OVER BAR

## PARTS

- 1 Roll over bar

## TOOLS

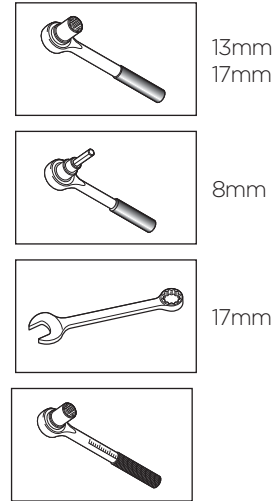

## FIXINGS

Pack J		CATERHAM		47	
		PACK NUMBER		30P010A	
ROLL OVER & TRACK DAY BAR SERIES 3 METRIC					
This pack may include extra fasteners to cover different options					
ITEM	BASIC DESCRIPTION	PART NUMBER	QTY	USED ON	ILLUSTRATION
1	Nut M10 x 20 Grade 8.8	BM10080	2	Rear diagonals of roll over bar to mounting brackets	
2	Set screw M8 x 20 Grade 8.8	SM8020	2	Roll over bar bracket to chassis	
3	Clamp nut M10 x 20	SMCH10X20	2	Roll over bar boss	
4	Nyloc Nut M10	NMNF10	2	Rear diagonals of roll over bar to mounting brackets	
5	Flan Washer M8	WPM88	2	Roll over bar bracket to chassis	
6	Spring Washer M8	WSP888	2	Roll over bar bracket to chassis	
7	Flan Washer M10	WPM1010	4	Rear diagonals of roll over bar to mounting brackets	

x2  
x2  
x2  
x2  
x2  
x2  
x4

## TIPS

If you've fitted the rear dampers they'll need to come off again to do this properly.

Chris B

# FITTING THE ROLL OVER BAR

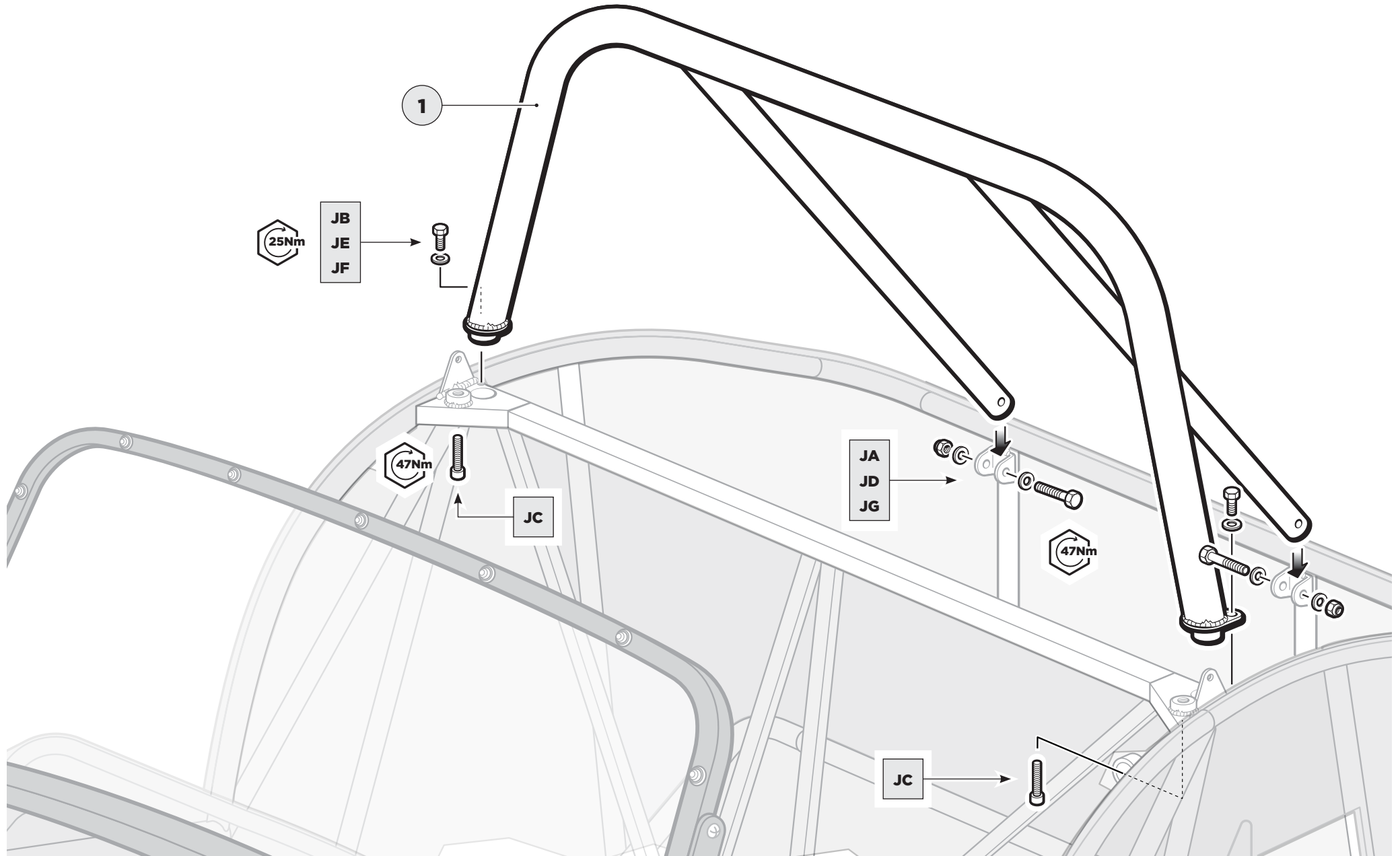

# EVEN MORE EXHAUSTING

## PARTS

- 1 Silencer
- 2 Exhaust clamp
- 3 Lambda sensor
- 4 Cat guard
- 5 Clip
- 6 Silencer mounting bracket
- 7 Exhaust mounting bobbin

## TOOLS



7mm  
10mm  
13mm

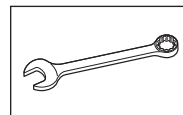

7/8"

## FIXINGS

Pack <b>G</b>		<b>CATERHAM</b>		56	
				PACK NUMBER	
				30X020E	
EXHAUST					
This pack may include extra fasteners to cover different options					
ITEM	BASIC DESCRIPTION	PART NUMBER	QTY	USED ON	ILLUSTRATION
1	GA Silencer MB X 25 Clutch 0.8	58KX25	1	Exhaust Mounting Bracket	
2	GB Flange Nut M8	NFFW8	2	Exhaust Bobbin	
3	GC Spring Washer M8	WSPM8	3	x 1 Exhaust Mounting Bracket x 2 Exhaust Bobbin	

x1  
x2  
x3

## TIPS

*Cable tie the Lambda sensor lead neatly out of the way.*

Lee A

# EVEN MORE EXHAUSTING

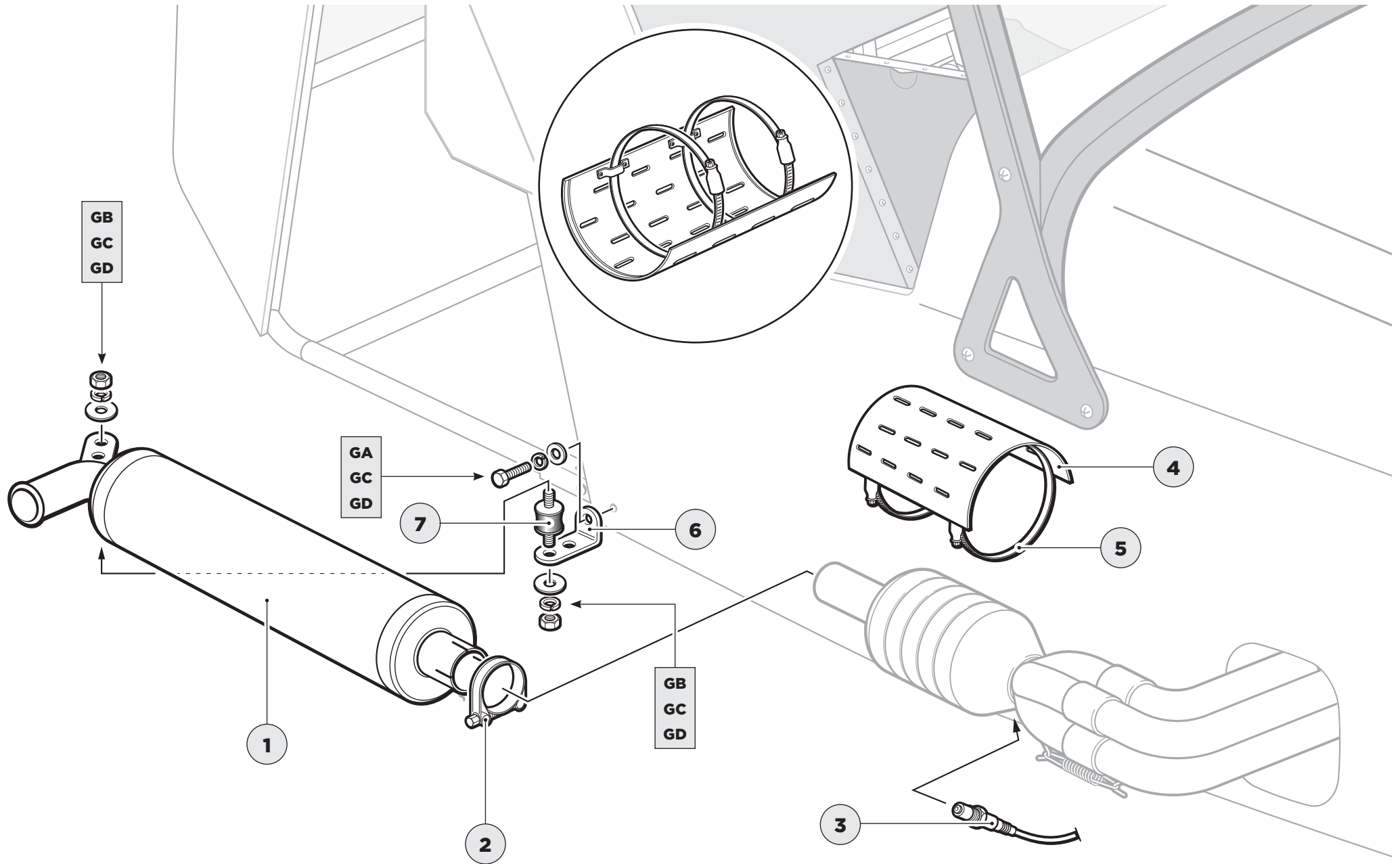

# THE NOSE CONE BADGE

## PARTS

- 1 Nose cone
- 2 Bonnet
- 3 Badge

## TOOLS

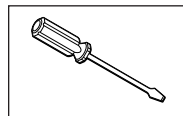

## FIXINGS

## TIPS

The nose cone goes on before the bonnet.

**Anthony L**

Stick the supplied foam around the edge of the nose and scuttle where the bonnet will sit (if you've not done already).

**Harry P**

# THE NOSE CONE BADGE

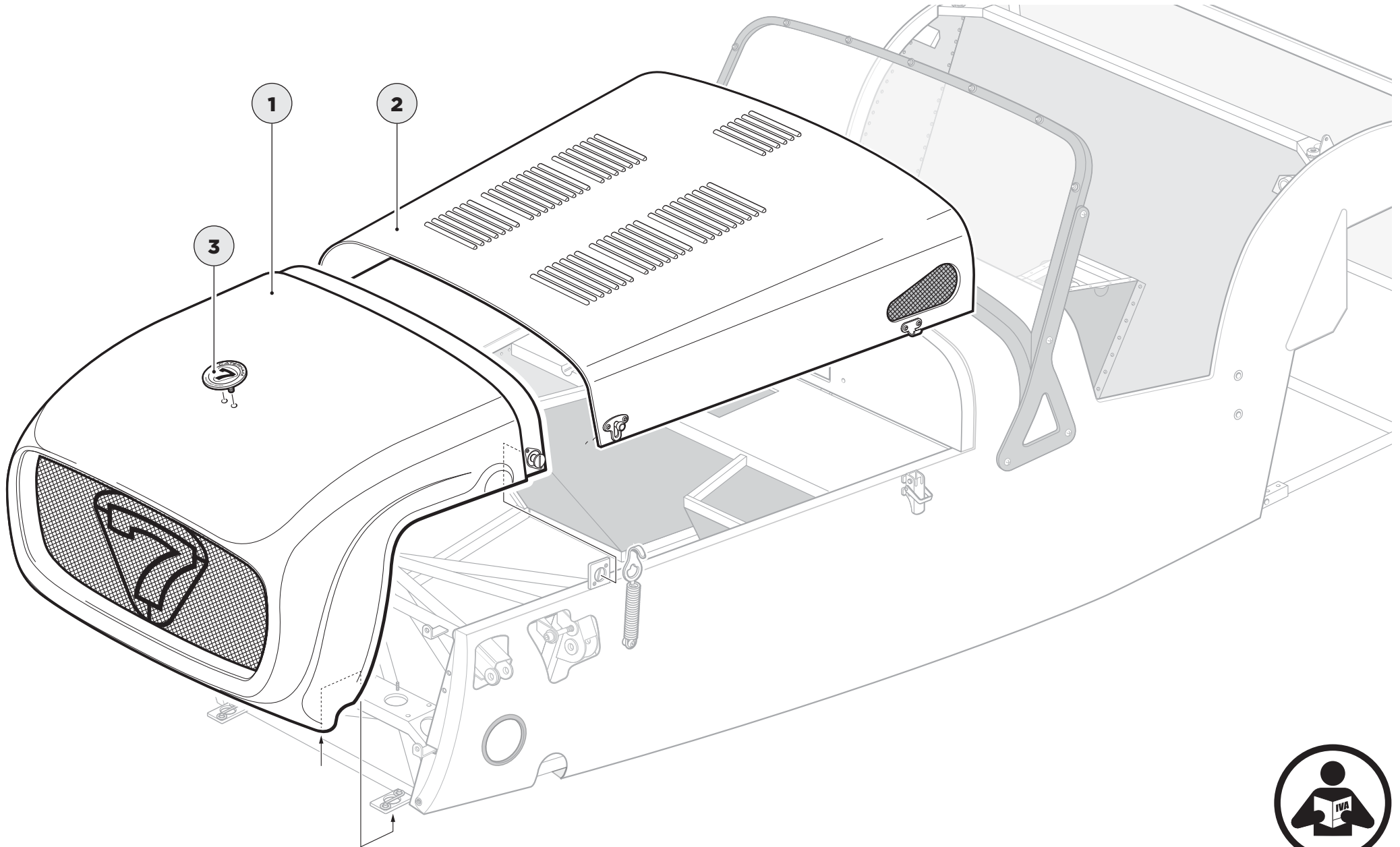

# FITTING THE WIPERS

---

## PARTS

- 1 Wiper arm
- 2 Wiper blade

## TOOLS

## FIXINGS

## TIPS

Ensure wipers are in *paused* position before fitting the wiper arms.

**John S**

Now would be a good time to fill the washer bottle with fluid and test the washers and wipers.

**Chris B**

## FITTING THE WIPERS

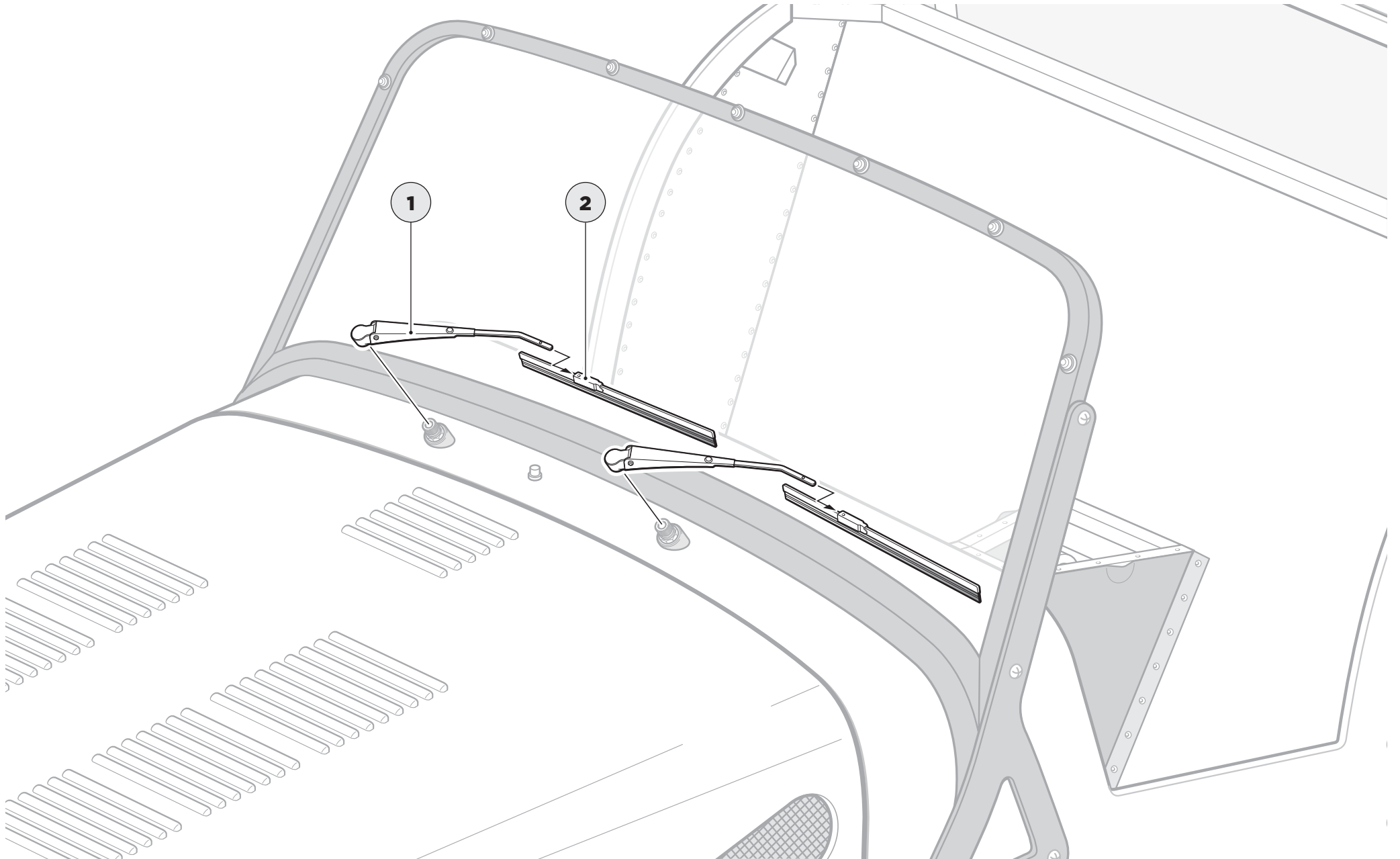

## AND FINALLY, AT LAST, THE WING MIRRORS

### PARTS

- 1 Mirror head
- 2 Mirror mount
- 3 Mirror mount stud
- 4 Grub screw
- 5 Fibre washer

### TOOLS

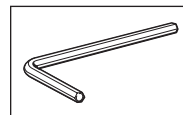
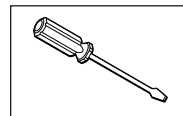

2.5mm

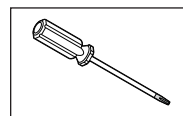

T20

### FIXINGS

Wing mirror bag

### TIPS

You may have to unclick the glass out to tighten up.

**Mick F**

## AND FINALLY, AT LAST, THE WING MIRRORS

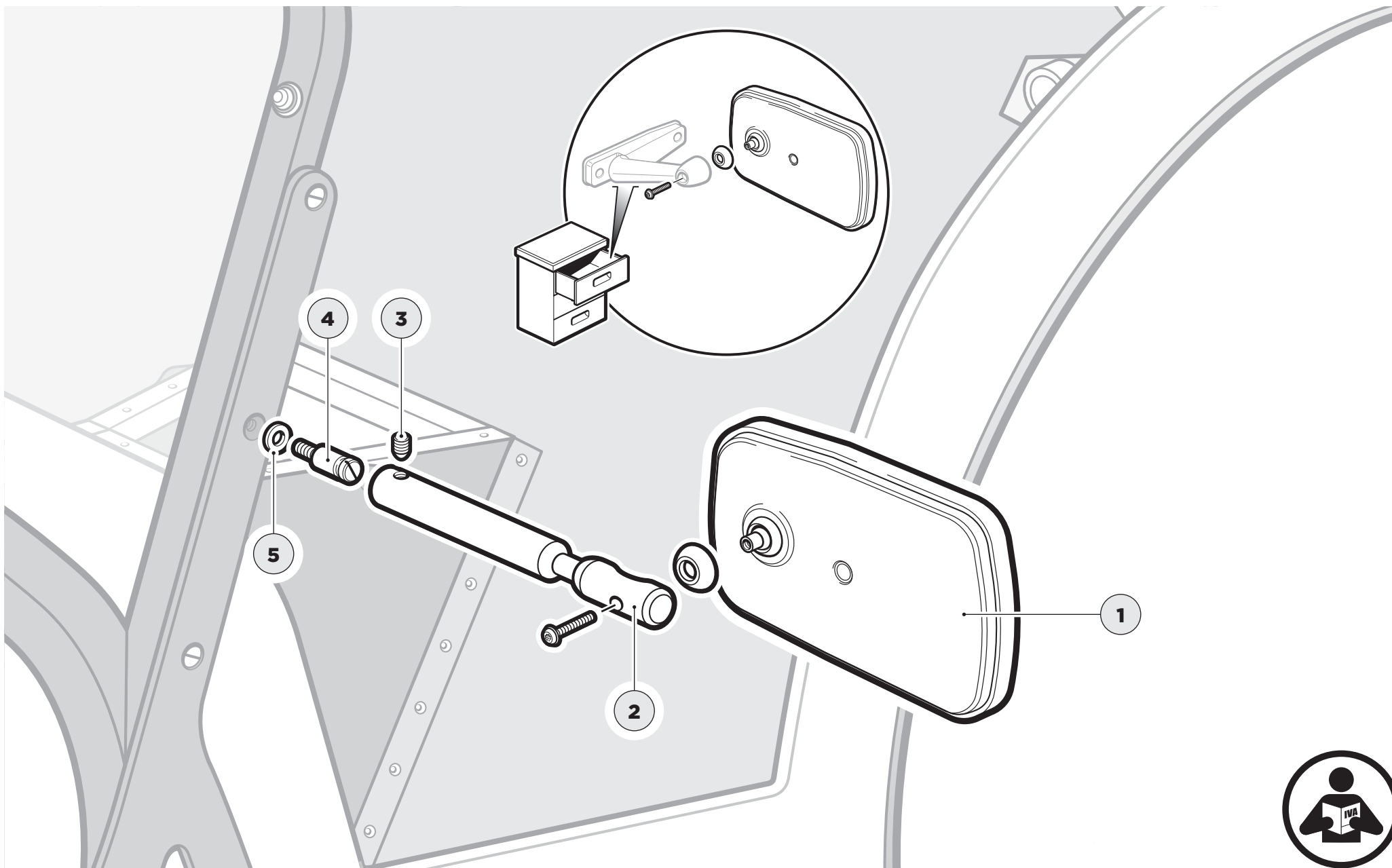

## WIRING THE STARTER MOTOR

---

### PARTS

- 1 Starter motor
- 2 Cable from alternator  
(brown wire with black sheath)
- 3 Cable from battery  
(positive - red wire)
- 4 2 cables from main loom  
(2 brown wires joined)
- 5 Cable from engine loom  
(white wire with red stripe)

### TOOLS

### FIXINGS

### TIPS

## WIRING THE STARTER MOTOR

---

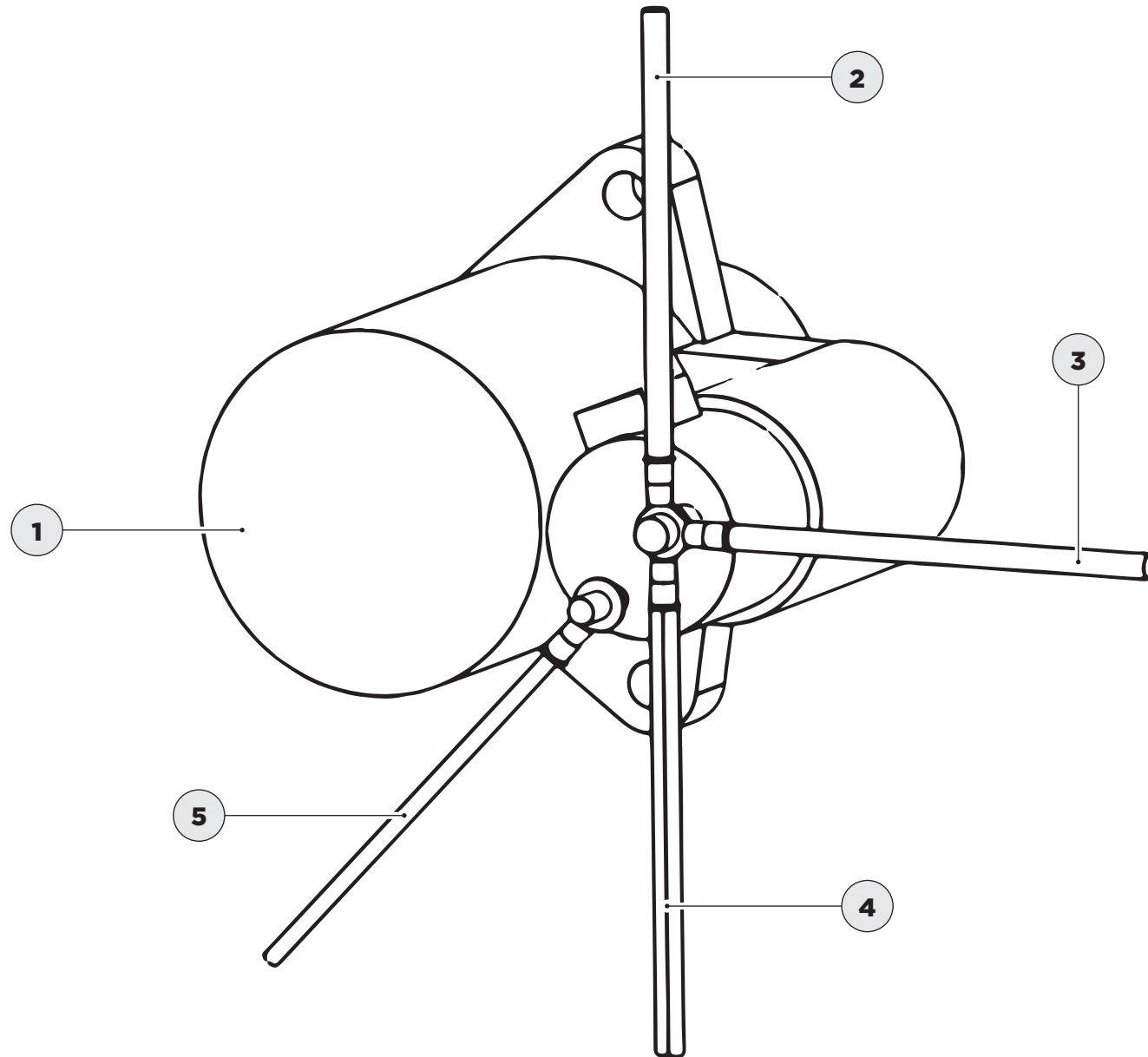

## THE LAST FEW STEPS...

Your car is almost complete, but before you can drive triumphantly out of the garage (and legally, as far as the end of your driveway) there are a few important things that need to be done. These are, bleeding the brakes, preparing the engine for its first grand firing-up ceremony (it will feel like that, even if you are doing it on your own) and lastly torquing up the suspension.

**So, on with bleeding the brakes which cannot be explained with a simple diagram unfortunately:**

- 1** Assemble the things you'll need: Brake fluid, both a 10mm and an 11mm spanner, a length of washer hose (or similar clear plastic hose) and a waste fluid receptacle (some form of used bottle is ideal; you won't want to use it again after this)
- 2** Find a volunteer. They need to be able to reach and press the brake pedal, plus respond to your instructions, so whilst a child is fine for this job, someone's might be more inclined to listen to you.
- 3** Fill the brake master cylinder with fresh brake fluid and leave the cap off. **BE CAREFUL NOT TO SPILL ANY ONTO THE PAINTWORK**; if you do, wipe it off immediately. Brake fluid will react with the paintwork causing it to blister and peel.
- 4** Starting at the left rear corner, locate the bleed nipple on the caliper. It will have a rubber cap on it. Remove the cap, remember where you put it, and attach the washer hose to the nipple and put the other end in the waste bottle. This sometimes needs the hose warming up in a cup of hot water to allow it to stretch over the nipple.

- 5 Using the 10mm spanner, 'crack off' the nipple about half of a turn.
- 6 Ask your assistant to pump the pedal a few times. You should see bubbly fluid flowing through the pipe. When the bubbles die down, ask them to hold the pedal down, then tighten the nipple back up. Check and top of the fluid level in the reservoir as necessary.
- 7 Ask them to lift off, then pump it a couple of times, then press the pedal down and hold it down.
- 8 Crack off the nipple again and let the fluid and bubbles flow. It will stop flowing as soon as your assistant has run out of brake pedal travel. Tighten the nipple.
- 9 Repeat steps 8 and 9 until you get 100% bubble free fluid passing through the pipe, remembering to check and top up the reservoir. You will waste quite a lot of brake fluid during this process.
- 10 Once you are satisfied that there are no more bubbles (no more air in the caliper), then you can remove the washer hose and refit the dust cover.
- 11 Repeat steps 5 to 10 for the remaining brakes in this order, right rear next, then right front and lastly left front. The front brake nipples use an 11mm spanner.
- 12 Although tedious, getting all the air out of the braking system is important and will give you a good, firm brake pedal, which is what you need; not a soft spongy one like you have in a regular car. You may need to repeat the whole process after the first drive or two (or even after the car has had a ride on a trailer); air in the braking system is very good at hiding.

Brakes bled and we are ready to fire up the engine. Again, it's easier to explain in writing than draw a diagram. The only thing you'll need for this job is to ensure that you have put some fuel in the car. The shape of the Caterham fuel tank does not lend itself to making use of every last drop, so we recommend an absolute minimum of 10 litres in the tank before trying to start the car. With the tank filled, we are ready for initialisation.

**But before anything else:**

**YOU DID REMEMBER TO PUT OIL IN THE ENGINE AND GEARBOX, RIGHT?**

- 1 Reassure yourself the engine is full of oil.
- 2 Disconnect the inertia switch; it's the black thing attached to the engine bay bulkhead under the windscreen that has rubber cap on top and a plug with two wires connecting from underneath. By disconnecting the inertia switch, the fuel pump will not work, so intentionally, the engine will not fire.
- 3 Ensure the gearbox is in neutral, then turn the ignition key and press and hold the start button.
- 4 As the engine cranks over, watch the oil pressure gauge. Keep cranking until the needle starts to climb, then steadies out.
- 5 We now have oil pressure circulating in the engine, which means the engine is ready to be started.
- 6 Reconnect the inertia switch.
- 7 Take a deep breath, mutter 'this is it', cross your fingers and brace yourself.
- 8 Turn the ignition key, press and hold the start button. It will take a few moments for the fuel to get through, so do not expect an instant start.
- 9 All things willing, the engine will start. Hooray! If it stops straight away, don't worry. Try again and once it starts give it a little rev.

# YOUR SEVEN *Adventure* AWAITS

That's it. Your car is complete! Well done – you have built a car; a real live car; not many people can say that. If you remembered to put in gearbox and differential oil, and fill the system with coolant, then a tentative edge out onto the driveway is in order. You'll need to pop the wheels on and lower it from the axle stands and just tighten the suspension first.

**Let's just run through that quickly:**

- i. Put a wheel on and do the nuts up a few turns by hand (to ensure they do not cross-thread).**
- ii. Tighten them up the best you can with the wheels off the ground.**
- iii. Lower the car from the axle stands, front first; taking care that it doesn't lean back on the axle stands at the back (a helper might be handy).**
- iv. Torque the wheel nuts to 65lbft (about 85Nm).**
- v. Flick back to the pages where we put the wishbones on and torque as shown**
- vi. That's it, you're ready to go!**

Take care and good luck with the IVA and registration process.

You will soon be experiencing the sheer pleasure of being a Caterham driver. Once again, enjoy!











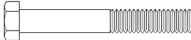

# APPENDIX









# FIXING PACKS

<b>Pack A</b>		<b>CATERHAM</b>			SERIAL NUMBER <b>44</b>	
					PACK NUMBER <b>30F015B</b>	
<b>FRONT SUSPENSION DeDION CARS (METRIC)</b>						
<i>This pack may include extra fasteners to cover different options</i>						
ITEM	BASIC DESCRIPTION	PART NUMBER	QTY	USED ON	ILLUSTRATION	
1	AA Bolt M12 x 100 Grade 10.9	BM12X100	2	Lower wishbone rear		
2	AB Bolt M12 x 65 Grade 10.9	BM12X65	2	Lower wishbone front		
3	AC Bolt M10 x 65 Grade 10.9	BM10X65	2	Upper wishbone rear		
4	AD Bolt M10 x 60 Grade 10.9	BM10X60	2	Upper wishbone front		
5	AE Bolt M8 x 40 Grade 10.9	BM8X40	4	Anti-roll bar mounting brackets		
6	AF Plain Nut M14 x 1.5 thread	NMPH14	1	Temporary use to help lock upper wishbone ball joint		
7	AG Nyloc Nut M12	NMYF12	2	Lower wishbone rear		
8	AH Nyloc Nut M10	NMYF10	4	Upper wishbone		
9	AJ Plain Washer M12 Chamfered	WPCM12	18	Lower wishbone		
10	AK Plain Washer M8 Heavy duty	WPHM8	4	Anti-roll bar mounting brackets		
11	AL Plain Washer 3/4" x 3/4" Heavy duty	WPH3/8	2	Brake pipe		
Drawings are for illustrative purposes only and are not to scale.					Page 1 of 2	

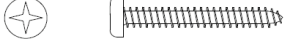
<b>Pack A</b>		<b>CATERHAM</b>			SERIAL NUMBER <b>44</b>	
					PACK NUMBER <b>30F015B</b>	
<b>FRONT SUSPENSION DeDION CARS (METRIC)</b>						
<i>This pack may include extra fasteners to cover different options</i>						
ITEM	BASIC DESCRIPTION	PART NUMBER	QTY	USED ON	ILLUSTRATION	
12	AM Spring Washer M12	WSHM12	2	Lower wishbone front		
13	AN Spring Washer M8	WSHM8	6	Anti-roll bar mounting brackets & upper damper mount		
14	AP Washer 3/4" Shake-proof	WSS3/8	2	Brake pipe		
15	AR Nyloc Nut 1/2" Half height	NFYH1/2	2	Wing stay		
16	AS Nyloc Nut 1/2" Full height	NFYF1/2	2	Front brake, upright mounting (std track ONLY)		
Drawings are for illustrative purposes only and are not to scale.					Page 2 of 2	

# FIXING PACKS

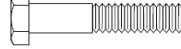
<b>Pack B</b>		<b>CATERHAM</b>		SERIAL NUMBER <b>55</b>	
				PACK NUMBER <b>3ACZ0021</b>	
		RELEASED NOV-19			
<b>STEERING DeDION CARS (METRIC)</b>					
<i>This pack may include extra fasteners to cover different options</i>					
ITEM	BASIC DESCRIPTION	PART NUMBER	QTY	USED ON	ILLUSTRATION
1	BA Caphead Bolt M6 x 70 DIN 912	BMCH6X70	4	Rack clamps	
2	BB Bolt 1/4" x 1 1/2"	BF1/4X1.1/2	2	Column clamp	
3	BC Bolt M8 x 40 Grade 10.9	BM8X40	2	Column to rack universal joint	
4	BD Nyloc Nut 1/2" Half height	NFYH1/2	1	Steering wheel boss	
5	BE Plain Nut 1/2"	NFPF1/2	2	Track rod lock nut	
6	BF Plain Nut 3/16" Half height	NFPFH7/16	1	Column clamp grubscrew locknut	
7	BG Nyloc Nut M8	NMYF8	2	Column to rack universal joint	
8	BH Nyloc Nut M6	NMYF6	4	Steering rack clamps	
9	BJ Plain Washer 1/2" x 1 1/4" Chamfered	WPH1/2	1	Steering wheel boss	
10	BK Plain Washer 3/4" Heavy duty	WPH1/4	6	Rack clamps and column clamp	
11	BL Spring Washer 3/4" Heavy duty	WSH1/4	2	Column clamp	
Drawings are for illustrative purposes only and are not to scale.					Page 1 of 1

<b>Pack C</b>		<b>CATERHAM</b>		SERIAL NUMBER <b>45</b>	
				PACK NUMBER <b>30L002B</b>	
		RELEASED NOV-19			
<b>LIGHTING &amp; HORNS</b>					
ITEM	BASIC DESCRIPTION	PART NUMBER	QTY	USED ON	ILLUSTRATION
1	CA Screw 10 x 1/2" Black Supaflange	71080	6	Indicator assembly to indicator pod	
2	CB Screw 8 x 1/2" Black Supaflange	71077	2	Side repeater earth on wingstay	
3	CC Screw 12 x 1 1/4" Self tapping	71079	4	Rear light cluster upper fixing	
4	CD Screw 12 x 1" Self tapping	71078	4	Rear light cluster lower fixing	
5	CE Nyloc Nut M6	NMYF6	2	Horn bracket to steering rack platform (160/270/310)	
6	CF Plain Washer 3/4" Heavy duty	WPH1/4	2	Horn bracket to steering rack platform (160/270/310)	
7	CG Bolt M8 x 5 Grade 8.8	BM8X50	1	Through steering rack platform & spacer (420)	
8	CH Plain Washer 5/16"	WPH5/16	2	Bolt head/nut	
9	CI Nyloc Nut M8	NMYF8	1	Horn bolt	
Drawings are for illustrative purposes only and are not to scale.					Page 1 of 1

# FIXING PACKS

Pack <b>D</b>		<b>CATERHAM</b>		SERIAL NUMBER	44
				PACK NUMBER	30C047B
COOLING SIGMA					
This pack may include extra fasteners to cover different options					
ITEM	BASIC DESCRIPTION	PART NUMBER	QTY	USED ON	ILLUSTRATION
1	DA Bolt M8 X 50 Grade 8.8	BM8X50	1	Expansion tank bracket to chassis	
2	DB Setscrew 1/4" X 3/4"	SF1/4X3/4	1	Expansion tank to bracket	
3	DC Setscrew M8X20 Grade 8.8	SM6X20	4	SV radiator bracket	
4	DD Bolt M6 X 16 with square section	30Z1072A	4	Fan brackets to fan	
5	DE Setscrew M6X16 Panhead Pozi	SPHM6X16	4	Fan to radiator cowling - SV only	
6	DF Nyloc Nut M6	NMYF6	8	x4 Fan to radiator x4 SV radiator bracket	
7	DG Plain Nut M8	NMPF8	8	Radiator bobbin	
8	DH Nyloc Nut 1/4"	NFYF1/4	1	Expansion tank bracket	
9	DI Plain Washer 1/4" Heavy duty	WPH1/4	13	8 x SV rad bracket 4 x Fan fixings 1 x Expansion tank bracket	
10	DJ Plain Washer 5/16" Heavy duty	WPH5/16	4	Radiator bobbin back	
11	DK Plain Washer 5/16" x 7/8" Heavy duty	WPH5/17X7/8	4	Radiator bobbin front	

Drawings are for illustrative purposes only and are not to scale.

Page 1 of 2

Pack <b>D</b>		<b>CATERHAM</b>		SERIAL NUMBER	44
				PACK NUMBER	30C047B
COOLING SIGMA					
This pack may include extra fasteners to cover different options					
ITEM	BASIC DESCRIPTION	PART NUMBER	QTY	USED ON	ILLUSTRATION
12	DL Plain Washer 1/4" x 7/8" Heavy duty	WPH1/4X7/8	1	Expansion tank bracket	
13	DM Spring Washer 5/16" Heavy duty	WSH5/17	9	8 x Radiator bobbin 1 x Expansion tank	
14	DN Hose Clip 30 - 40mm	SGT25-40	6	2 x U shape hose to water rail 2 x Top radiator hose 2 x Bottom radiator hose	
15	DO Hose Clip 23 - 35mm	SGT23-35	2	1 x Engine outlet to big T piece 1 x Engine outlet to heater inlet	
16	DP Hose Clip 17 - 25mm	SGT16-25	18	6 x Heater inlet/outlet 3 x Big T-piece 1 x Expansion tank 2 x Modine 4 x Dry Sump 2 x Submarine	
17	DQ Hose Clip 8 - 16mm	SGT8-16	6	Expansion tank small T-piece	
18	DR Rivet - Black 5/32" X 0.47"	1610-01015	12	Cowling flap	

Drawings are for illustrative purposes only and are not to scale.

Page 1 of 2

# FIXING PACKS

Pack <b>E</b>		<b>CATERHAM</b>		SERIAL NUMBER	66
				PACK NUMBER	3EZ1105F
SIGMA GEARBOX 5 SPEED					
<i>This pack may include extra fasteners to cover different options</i>					
ITEM	BASIC DESCRIPTION	PART NUMBER	QTY	USED ON	ILLUSTRATION
1	EA Bolt M14 X 40 Grade 12.9	3EZ1137A	2	AV Mount	
2	EB Caphead Bolt M8 X 40 Grade 12.9	30Z1076A	4	AV Mount	
3	EC Caphead Bolt M12 X 50 Grade 12.9 Coarse Thread	3EZ1142A	4	Gearbox	
4	ED Caphead Bolt M10 X 60 Grade 12.9	BMCH10X60	4	1 x Bellhousing 3 x Starter Motor	
5	EE Caphead Bolt M10 X 55 Grade 12.9	BMCH10X55	3	Bellhousing	
6	EF Caphead Bolt M10 X 40 Grade 12.9	BMCH10X40	3	Bellhousing	
7	EG Caphead Bolt M10 X 35 Grade 12.9	BMCH10X35	2	Engine Mount RHS Top	
8	EH Caphead Bolt M8 X 25 Grade 12.9	BMCH8X25	2	Engine Mount 1 x LHS Top 1 x LHS Bottom	
9	EI Caphead Bolt M8 X 30 Grade 12.9	BMCH8X30	1	Engine Mount LHS Bottom	
10	EJ Caphead Bolt M8 X 35 Grade 12.9	BMCH8X35	2	Engine Mount RHS Bottom	
11	EK Caphead Bolt M6 X 25 Grade 12.9	BMCH6X25	3	Clutch Slave Cylinder	

Drawings are for illustrative purposes only and are not to scale.









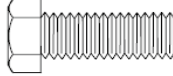

Page 1 of 2



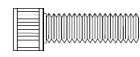

Pack <b>E</b>		<b>CATERHAM</b>		SERIAL NUMBER	66
				PACK NUMBER	3EZ1105F
SIGMA GEARBOX 5 SPEED					
<i>This pack may include extra fasteners to cover different options</i>					
ITEM	BASIC DESCRIPTION	PART NUMBER	QTY	USED ON	ILLUSTRATION
12	EL Buttonhead Bolt M6 X 10 Grade 10.9 Internal Hex	3GZ1163A	3	Gear Lever	
13	EM Plain Washer M14	WPH14	2	AV Mount	
14	EN Plain Washer M12	30Z2031A	4	Gearbox	
15	EO Plain Washer M6	WPHM6	3	Gear Lever	
16	EP Plain Washer 5/16"	WPH5/16	8	AV Mount	
17	EQ Spring Washer M12	WSHM12	4	Gearbox	
18	ER Spring Washer M10	WSHM10	10	x 7 Bellhousing 3 Engine Mount	
19	ES Wire Spring Washer M10	WSHM10	3	Starter Motor	
20	ET Spring Washer M8	WSHM8	5	Engine Mount	
21	EU Spring Washer M6	WSHM6	3	Clutch Slave Cylinder	
22	EV Myloc Nut M8	NMYF8	4	AV Mount	
23	EW Spring Washer M14	30Z2030A	2	AV Mount	

Drawings are for illustrative purposes only and are not to scale.

Page 2 of 2

# FIXING PACKS

<b>Pack F</b>		<b>CATERHAM</b>		SERIAL NUMBER <b>66</b>	
				PACK NUMBER <b>3EZ2029B</b>	
<b>DURATEC GEARBOX 5 SPEED</b>					
<i>This pack may include extra fasteners to cover different options</i>					
ITEM	BASIC DESCRIPTION	PART NUMBER	QTY	USED ON	ILLUSTRATION
1	FA Bolt M14 X 30 X 1.5 Grade 12.9	30Z2032A	2	AV Mount	
2	FB Caphead M12 X 40 X 1.75 Grade 12.9	BMCH12X40	4	Bellhousing	
3	FC Caphead Bolt M10 X 90 Grade 12.9	BMCH10X90	1	Bellhousing	
4	FD Caphead Bolt M10 X 55 Grade 12.9	BMCH10X55	3	Bellhousing	
5	FE Caphead Bolt M10 X 45 Grade 12.9	BMCH10X45	7	x 5 Bellhousing x 2 Starter Motor	
6	FF Caphead Bolt M8 X 40 Grade 12.9	30Z1076A	4	AV Mount	
7	FG Caphead Bolt M6 X 25 Grade 12.9	BMCH6X25	3	Clutch Release Bearing	
8	FH Buttonhead Bolt M6 X 10 Grade 10.9 Internal Hex	3GZ1163A	3	Gear Lever	
9	FI Nyloc Nut M8	NMYF8	4	AV Mount	
10	FJ Plain Washer M14	WPH14	2	AV Mount	
11	FK Plain Washer M12	30Z2031A	4	Bellhousing	
Drawings are for illustrative purposes only and are not to scale.					Page 1 of 2

<b>Pack F</b>		<b>CATERHAM</b>		SERIAL NUMBER <b>66</b>	
				PACK NUMBER <b>3EZ2029B</b>	
<b>DURATEC GEARBOX 5 SPEED</b>					
<i>This pack may include extra fasteners to cover different options</i>					
ITEM	BASIC DESCRIPTION	PART NUMBER	QTY	USED ON	ILLUSTRATION
12	FL Plain Washer M6	WPHM6	3	Gear Lever	
13	FM Spring Washer M14	30Z2030A	2	AV Mount	
14	FN Spring Washer M12	WSHM12	4	Gearbox	
15	FO Spring Washer M10	WSHM10	4	x 2 Starter Motor x 2 Front Bellhousing	
16	FP Spring Washer M6	WSHM6	3	Clutch Slave Cylinder	
Drawings are for illustrative purposes only and are not to scale.					Page 2 of 2

# FIXING PACKS



Pack **G**

**CATERHAM**

SERIAL NUMBER	<b>56</b>
PACK NUMBER	<b>30X020B</b>

## EXHAUST

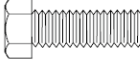





*This pack may include extra fasteners to cover different options*

ITEM	BASIC DESCRIPTION	PART NUMBER	QTY	USED ON	ILLUSTRATION
1	GA Setscrew M8 X 25 Grade 8.8	SM8X25	1	Exhaust Mounting Bracket	
2	GB Plain Nut M8	NFPF8	2	Exhaust Bobbin	
3	GC Spring Washer M8	WSHM8	3	x 1 Exhaust Mounting Bracket x 2 Exhaust Bobbin	

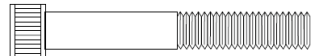
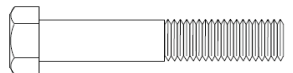
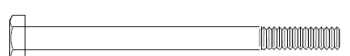
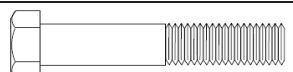
Drawings are for illustrative purposes only and are not to scale.





Page 1 of 1

# FIXING PACKS

Pack <b>H</b>		<b>CATERHAM</b>		SERIAL NUMBER <b>53</b>	
				PACK NUMBER	
				30R011D	
REAR SUSPENSION DEDION METRIC					
<i>This pack may include extra fasteners to cover different options</i>					
ITEM	BASIC DESCRIPTION	PART NUMBER	QTY	USED ON	ILLUSTRATION
1	HA Bolt M12 X 100 Grade 10.9	BM12X100	2	A-frame front mountings	
2	HB Caphead Bolt M10 X 65	BMCH10X65	2	Front radius arm (through cockpit)	
3	HC Bolt 1/2" X 2.1/2" Grade 10.9	BF1/2X2.1/2	4	x 2 Lower Rear Damper 2 Rear Radius Arm	
4	HD Bolt M6 X 80 Grade 10.9	BM6X80	4	Rear Anti Roll Bar Mounting Blocks	
5	HE Bolt 1/2" X 2.3/4" Grade 10.9	BF1/2X2.3/4	1	A-frame to DeDion	
6	HF Half Nyloc 1/2" UNF	NFYH1/2	3	x 2 Rear Radius Arm 1 A-frame to DeDion	
7	HG Nyloc Nut M12	NMYF12	2	A-frame front mounts	
8	HH Nyloc Nut M10	NMYF10	2	Front radius arm (through cockpit)	
9	HI Half Nyloc M8	NMYH8	2	Rear Anti Roll Bar Drop Link	
10	HJ Nyloc Nut M6	NMYF6	4	Rear Anti Roll Bar Mounting Blocks	
11	HK Nyloc Nut 1/4"	NFYF1/4	1	3 - way union on DeDion tube	

Drawings are for illustrative purposes only and are not to scale.

Page 1 of 2

Pack <b>H</b>		<b>CATERHAM</b>		SERIAL NUMBER <b>53</b>	
				PACK NUMBER	
				30R011D	
REAR SUSPENSION DEDION METRIC					
<i>This pack may include extra fasteners to cover different options</i>					
ITEM	BASIC DESCRIPTION	PART NUMBER	QTY	USED ON	ILLUSTRATION
12	HL Washer	79029	10	Differential Isolation	
13	HM Plain Washer 1/2" Chamfered	WPH1/2	20	x 2 Lower Damper x 10 A-frame washers 4 Radius Arm	
14	HN Plain Washer 3/8" X 7/8"	WPH3/8X7/8	2	Front Radius Arm	
15	HO Plain Washer M6	WPHM6	4	Rear Anti Roll Bar Mounting Block	
16	HP Schnorr Washer M12	30Z1069A	2	Lower Damper	

Drawings are for illustrative purposes only and are not to scale.



Page 2 of 2





# FIXING PACKS

<b>Pack J</b>		<b>CATERHAM</b>			SERIAL NUMBER <b>47</b>	
					PACK NUMBER <b>30P010A</b>	
<b>ROLL OVER &amp; TRACK DAY BAR SERIES 3 METRIC</b>						
<i>This pack may include extra fasteners to cover different options</i>						
ITEM		BASIC DESCRIPTION	PART NUMBER	QTY	USED ON	ILLUSTRATION
1	JA	Bolt M10 X 60 Grade 8.8	BM10X60	2	Rear diagonals of roll over bar to mounting brackets	
2	JB	Setscrew M8 X 20 Grade 8.8	SM8X20	2	Roll over bar bracket to chassis	
3	JC	Caphead Bolt M10 X 20	BMCH10X20	2	Roll over bar boss	
4	JD	Nyloc Nut M10	NMYF10	2	Rear diagonals of roll over bar to mounting brackets	
5	JE	Plain Washer M8	WPHM8	2	Roll over bar bracket to chassis	
6	JF	Spring Washer M8	WSHM8	2	Roll over bar bracket to chassis	
7	JG	Plain Washer M10	WPHM10	4	Rear diagonals of roll over bar to mounting brackets	
Drawings are for illustrative purposes only and are not to scale.						Page 1 of 1

<b>Pack O</b>		<b>CATERHAM</b>			SERIAL NUMBER	
					PACK NUMBER <b>ZWS01</b>	
<b>WING PROTECTORS STAINLESS STEEL</b>						
<i>This pack may include extra fasteners to cover different options</i>						
ITEM		BASIC DESCRIPTION	PART NUMBER	QTY	USED ON	ILLUSTRATION
1	OA	Rivet 1/8" X 0.51"	1661-0414	30	Wing protector to wing	
2	OB	Wing Piping	76901	2m	Between wing protector and wing	
Drawings are for illustrative purposes only and are not to scale.						Page 1 of 1

# FIXING PACKS

<b>Pack P</b>		<b>CATERHAM</b>		SERIAL NUMBER	
				PACK NUMBER	
				ZWS02	
<b>WING PROTECTORS CARBON FIBRE</b>					
<i>This pack may include extra fasteners to cover different options</i>					
ITEM	BASIC DESCRIPTION	PART NUMBER	QTY	USED ON	ILLUSTRATION
1	PA Rivet Black 1/8" X 0.51"	1610-01049	30	Wing protector to wing	
2	PB Wing Piping	76901	2m	Between wing protector and wing	
Drawings are for illustrative purposes only and are not to scale.					Page 1 of 1

<b>Pack Q</b>		<b>CATERHAM</b>		SERIAL NUMBER	
				31	
				PACK NUMBER	
				ZFG12	
<b>REAR WINGS</b>					
<i>This pack may include extra fasteners to cover different options</i>					
ITEM	BASIC DESCRIPTION	PART NUMBER	QTY	USED ON	ILLUSTRATION
1	QA Set Screw M5 X 20	SM5X20	20	Rear Wings	
2	QB Nylc Nut M5	NMYF5	10	Rear wings through boot	
3	QC Plain Washer 3/16" X 3/4"	WP3/16X3/4	30	Wing washers	
4	QD Wing Piping 1/4" X 1"	76902	4m	Between wing and body	
Drawings are for illustrative purposes only and are not to scale.					Page 1 of 1



**CATERHAM®**

Caterham Cars Limited, 2-3 Kennet Road, Dartford, Kent, DA1 4QN  
+44 (0) 1322 625800

**CATERHAMCARS.COM**

 /CaterhamCars  @caterhamcars

Content is subject to change without notice.  
© Caterham 2021  
Edition 2.1D 03/21  
Images are for illustrative purposes only.